

CEMETERY COMMISSION MONTHLY MEETING
DONN B. GRIFFIN ROOM, TOWN HALL
732 MAIN STREET
TUESDAY AUGUST 2, 2022 AT 9:00AM

Public may attend the meeting in person, access the meeting on Channel 18 (Broadcasting Live), or can login to the meeting remotely using the following login information

Please join my meeting from your computer, tablet or smartphone.

<https://meet.goto.com/787436061>

You can also dial in using your phone.

United States: [+1 \(571\) 317-3122](tel:+15713173122)

Access Code: 787-436-061

New to GoToMeeting? Get the app now and be ready when your first meeting starts: <https://meet.goto.com/install>

- I. CALL TO ORDER
- II. APPROVAL OF THE MINUTES FROM DECEMBER 15, 2021 AND JUNE 7, 2022.
- III. CORRESPONDENCE FROM TOWN HALL & ASSOCIATIONS
 - A. Letter from Juell E. Buckwold on removal of two shrubs on lot in Evergreen Cemetery.
 - B. Letter from Helene Lambert on her father's lot in Island Pond Cemetery.
 - C. Email with updated 2022-2023 Selectmen Liaison Assignments.
 - D. Letter from Tricia & Dave Vanderwater in Island Pond.
 - E. Donated tree planted by Elizabeth Lamb in Island Pond Cemetery.
 - F. Email from Phoebe Plank, the Town of Harwich's Individual Placement Application is all set for the upcoming 2022-2023 program year.
 - G. Email from Phoebe Plank on End of Year Evaluation for IP.
 - H. Email from Joe Powers to Cemetery Administrator in response from request from Duncan Berry on West Harwich Baptist Church Property.
- I. OTHER BUSINESS.
- IV. OLD BUSINESS
 - A. Up to date totals for Revolving Account and Cemetery Budget.
 - B. Email from Meggan Eldredge on Procurement documents for Veterans Memorial Circle at Evergreen.
 - C. Update on Veterans memorial circle and price quote on granite flag pole base from Coldsprings.
 - D. Email from Meggan Eldredge on signed documents on the Evergreen Cemetery Software to go out to BID.
 - E. Email sent to CPC updating on process of Articles.
 - F. Email from Meggan Eldredge IFP for East Harwich Union Cemetery Gravestone.
 - G. Update on tours of cemeteries.
 - H. No Dog Walking Signs.
 - I. OTHER OLD BUSINESS.

V. NEW BUSINESS

- A. Estimate from Warren Nichols Landscaping& Design for insect to control for Evergreen Cemetery 5 Acre section for \$1,200.00.
- B. BILLS. Eversource, Village Green Restoration CPC Article Finished \$42,900.00
- C. DEEDS: Rose Hemeon for 519B West Main Ave West (Grave #4) in Island Pond for \$800.00, JoAnne Brown for 101D Pond Grove in Island Pond for \$500.00, Susan D Gunderson 1015 East Main Ave East in Island Pond \$800.00, Brian & Carole Powers 11 Neptune Ave (Graves 1 to 6) in Island Pond for \$4,800.00.
- D. Final Tree Tour in Island Pond Cemetery on July 19 from 9:30 to 10:30 by AmeriCorps members Maddy Oerth and Jodi Monroe.
- E. OTHER BUSINESS.

VI. DATE AND TIME OF NEXT MEETING

VII. ADJOURNMENT

AUTHORIZED POSTING OFFICER:

POSTED BY: _____
TOWN CLERK

DATE: _____

6/30/22

Harwich Cemetery Commission
Att: Robin Kelley

I am writing in regard to
Lot 176, 1948 Ave. (Moody / Menengas)
Evergreen Cemetery, East Harwich.

There are two shrubs on the
lot that have / are overgrowing
the headstone and need to be
removed.

Is there something the Town
can take care of or how do I
go about seeing they are removed.

Thank you for your help.

I can be reached at 508-432-1055
or P.O. Box 51, Harwich, MA 02645.

Thank you again.

Jeane Moody Buckwold

271 1948 Ave
Menengas / Moody Lot

TOWN OF HARWICH
SCHEDULE OF DEPARTMENTAL BILLS PAYABALE

To the Town Accountant or Accounting Officer:-

The following named bills of the **CEMETERY DEPARTMENT**, amounting in the aggregate to **--Six Hundred 00/100 Dollars**, have been approved by the **CEMETERY COMMISSION** and you are requested to place them on a warrant for payment.

 Harwich Cemetery Commission

Date: 11-Jul-22

NAME	ADDRESS		TOTAL
Helene Lambert Lot # 956 & 957 Dune Ave Island Pond	Helene Lambert 5216 CookBrook 43X 2L1 Montreal, QC Canada		\$600.00
<div style="border: 1px solid black; padding: 10px; margin: 0 auto; width: 80%;"> <p>Lot Return to Town</p> <p>16111004-481003</p> </div>			
TOTAL		\$0.00	\$600.00

June 28th 2022

My father Yves LAMBERT
bought a lot in 1999 in the
Island Pond Cemetery.

Sadly he passed away in
France last year and is now
buried there.

Please refund what he payed
them (600\$) to me:

Helene Lambert: 5216 Coolbrook
H3X 2L1
Montreal, Qc
CANADA

sincerely,

~~H. Lambert~~

514-589-7102

Know all Men by these Presents: - That the Town of Harwich, a corporation duly established by law, in consideration of the sum of Six Hundred 00/100 (\$600.00) * Dollars, paid by Yves M. Lambert 1220 Orleans Road, Harwich MA 02645 (508-430-2642)

the receipt whereof is hereby acknowledged, does hereby give, grant, bargain, sell and convey unto the said Yves M. Lambert Exclusive Rights of Burial in one Lot of land in the Cemetery called the Island Pond Cemetery in Harwich in the County of Barnstable and Commonwealth of Massachusetts, which said lot contains 80 superficial square feet and is numbered #956 & 957 Dune Avenue on the plan of said Cemetery, in the possession of the Corporation, and which may be inspected by the grantee Yves M. Lambert, his heirs and assigns, at all reasonable times.

To have and to hold the aforegranted premises, unto the said Yves M. Lambert, his

heirs and assigns, to their own use and behoof forever, subject nevertheless to the by-laws of said corporation and to all rules, regulations and restrictions now or hereafter made by the Cemetery Commission of said Corporation relative to said Cemetery and the lots therein.

And the said Town of Harwich hereby covenants with said Yves M. Lambert, his heirs and assigns, that it is seized in fee simple of the aforegranted premises, that the granted premises are free from all incumbrances, except as aforesaid, that it has good right to sell and convey the same to the said Yves M. Lambert and will warrant and defend the same unto the said Yves M. Lambert, his heirs and assigns forever against the lawful claims and demands of all persons except as aforesaid.

In Witness Whereof the said Town of Harwich has caused its common seal to be hereto affixed, and these presents to be signed and executed in its name and behalf by its Cemetery Commission, this 14th day of September in the year of our Lord one thousand nine hundred and ninety-nine.

Signed, sealed and delivered in the presence of

TOWN OF HARWICH
by [Signature]
Olga R. Jones
J. L. Shaw
Cemetery Commission

Commonwealth of Massachusetts

ss. September 14 19 99

Then personally appeared the above named Cemetery Commission, and acknowledged the foregoing instrument to be the free act and deed of the Town of Harwich.

My Commission expires Before me, Maureen S. Myers Notary Public
May 21, 2004 OFFICE OF CEMETERY COMMISSION, September 14 19 99

I hereby certify that the foregoing Deed has been entered and recorded in this office, in the Book provided for that purpose, being Book No. 12 Page No. 16
Maureen S. Myers Clerk

* 50% dedicated to Perpetual Care.

YVES LAMBERT OBITUARY

 Search by Name

Yves LAMBERT

[Send Flowers](#)

 [Share](#)

YVES LAMBERT OBITUARY

YVES LAMBERT Odile Lambert (nee Revillon) is saddened to announce the death of her husband, Yves Lambert, in Paris on March 27, 2021. He leaves behind five children, Jean, Cecile, Marc, Helene and Paul, eleven grandchildren, and two great- granddaughters. A graduate of the Ecole Polytechnique (1956, Paris), he served as Secretary General of ICAO (Montreal), Director General of Air Traffic Management (Paris), and Director General of Eurocontrol (Brussels). He was an officer of the Legion of Honour (France) and a Commander of the National Order of Merit (France). A private funeral service was held.

Published by The Globe and Mail from Apr. 10 to Apr. 14, 2021.

To plant trees in memory, please visit the [Sympathy Store](#).



DOGPOOPSIGNS.COM

NO DOG PEE SIGNS, NO DOG PEE ON...

LawnBoss Sign & Stake Kit - No Dog Pee Signs, No Dog Pee On Hedges



Selectmen's Policy: The Role of a Liaison

On an annual basis, individual members of the Board of Selectmen will be assigned as liaisons to the various Boards and Committees appointed by the Board of Selectmen. The primary function of the liaison is to improve communications and understanding between the Board of Selectmen and the relevant committee. The liaison is not a member of the committee and should not participate in the work of the committee.

The Selectmen's liaison to any committee should become familiar with: matters with which the appointed committees are dealing; the public input, if any, at committee meetings; the need for interaction with other committees; the need for support from town departments; the manner in which meetings are conducted; committee members' attendance issues. The liaison can and will convey pertinent information about committee activities to the Board of Selectmen and/or Town administrator as appropriate.

The liaison should establish a working relationship with the Chairperson of the committee such that the Chairperson feels free to communicate specific requests for support and/or information from the Board of Selectmen

Further, the liaison can convey information about Board of Selectmen discussions or actions taken that pertain to topics under consideration by committees that have to do with procedures or Town policies. However, the liaison should not become involved in committee deliberations or try to channel a committee's work product toward or away from a particular conclusion unless, for example, the liaison is aware of a pertinent Town Counsel opinion.

Moreover, it needs to be understood that the liaison as well as the entire Board of Selectmen must refrain from taking positions on matters pending before some appointed committees when they are performing their regulatory function and operating primarily under State law: Board of Health, Conservation Commission, Planning Board, and Zoning Board of Appeals. In that specific capacity, such committees are autonomous after having been appointed by the Board of Selectmen.

First Reading — June 17, 2013

Second Reading - June 24, 2013

Third Reading — July 1, 2013

2022-2023 Selectmen Liaison Assignments

<p>Michael MacAskill, Chair mmacaskill@townofharwich.us</p>	<p>Ambulance Waiver Administrator Waterways Committee Real Estate And Open space Water/Wastewater Commission Board of Health Agricultural Commission</p>
<p>Donald F. Howell, Clerk dhowell@townofharwich.us</p>	<p>Brooks Academy Museum Commission Conservation Committee Cemetery Commission Golf Committee Planning Board Historic District/Historic Commission Housing Authority</p>
<p>Larry Ballantine Interview Committee lballantine@townofharwich.us</p>	<p>Board Of Appeals Disability Rights Committee Treasure Chest Volunteer Committee Council On Aging Library Trustees Community Preservation Community Board of Assessors</p>
<p>Mary Anderson, Vice Chair manderson@townofharwich.us</p>	<p>Voter Information Committee Housing Committee Youth Services Committee Finance Committee Cultural Council Chamber Of Commerce Capital Outlay Committee</p>
<p>Julie Kavanagh Interview Committee jkavanagh@townofharwich.us</p>	<p>Monomoy Regional School Committee Bikeways Committee Traffic Safety Committee Harwich Energy & Climate Action Committee Recreation and Youth By Law and Charter Review Community Center Facilities Committee</p>



.....
A NOTE OF THANKS
.....

So...
We just found out you spell
your name w 2 b's 😊 Sorry!!
You were so very helpful to
us! We hope your "matie"
planting went very well, &
we contributed a bit to the
flora.



For
EVERYTHING

you do!

It was a pleasure to
meet with you & chat.



Tricia & Dave Vandewater
Thanks for "turning us loose" 😊



Stewartia pseudocamellia

(Japanese Stewartia)

Donated by Elizabeth Lamb

Planted on July 5, 2022

Lily Pond, Island Pond





AmeriCorps Cape Cod Individual Placement Evaluation

Member Name: Madeline Oerth

Partner Organization: Town of Harwich Marceline
Arboretum at Island Pond

Service Partner Name: Robbin Kelley

This evaluation is for the following time frame: (check applicable box)

October - January

February – June

Member evaluations are based on expectations and guidelines outlined in the AmeriCorps Cape Cod Program Handbook and Contract, as well as those expectations outlined during the member’s Individual Placement orientation. **Part I and II** should be used to identify your member’s strengths and areas for improvement while serving at your organization on the assigned Individual Placement Project(s). Please use the following rating system to review and evaluate your member’s performance in each of the key areas listed below within the time period indicated. Please utilize the comment section to address any additional strengths and areas for improvement. **Part III** should be used to identify strengths and challenges with the Individual Placement Project. **Part IV** should be used to identify upcoming goals and/or priorities you have for your Individual Placement member. **Part V** should include comments from your Individual Placement member after you have reviewed the evaluation with them.

Ratings for **Parts I and II** are defined as follows:

- 1 = member is consistently not meeting the service standards and expectations set forth by the program and Individual Placement
- 2 = member sometimes meets the service standards and expectations
- 3 = member is on track and meets the service standards and expectations
- 4 = member consistently exceeds service standards and expectations
- 5 = member far exceeds service standards and expectations

Part I: Performance Review – Personal Qualities

	1	2	3	4	5	N/A
Member shows a commitment to service				X		
Member demonstrates a positive attitude					X	
Member is reliable and punctual				X		
Member demonstrates initiative				X		
Member demonstrates good communication skills				X		
Member demonstrates leadership skills				X		

Comments: Maddy had been a positive member and has shown professionalism in her work ethic.

Part II: Performance Review – Professional Qualities

	1	2	3	4	5	N/A
Member demonstrates professionalism including conduct and appearance				X		
Member shows a willingness and ability to learn new skills				X		
Member serves effectively with service site staff and independently when necessary				X		
Member follows through on projects effectively and in a timely manner				X		
Member demonstrates initiative – finds tasks when not given defined assignments				X		
Member uses available resources in an effective manner				X		
Member follows safety procedures and guidelines				X		
Member accepts direction and feedback appropriately, implements change in behavior when needed				X		
Member engages and serves effectively with volunteers					X	

Comments: Maddy has learned so much in regards to plantings and design of gardens. She works well with others to get tasks accomplished.

Robbin Kelley

From: Katherine Garofoli <katherine.garofoli@barnstablecounty.org>
Sent: Thursday, July 21, 2022 3:21 PM
Subject: AmeriCorps Cape Cod graduation and the final Year 23 WayPoint!
Attachments: ACC YR 23 WayPoint_Issue 3_July 2022.pdf

I am happy to share the last edition of the Year 23 AmeriCorps Cape Cod WayPoint newsletter (attached to this email). You can also access it here:  [ACC YR 23 WayPoint Issue 3 July 2022.pdf](#) This member-driven communication gives readers a “sneak peak” into the service year and all of the exciting activities that our members participate in.

Don't forget! The Year 23 AmeriCorps Cape Cod graduation takes place a week from today! See invitation below. The refreshment portion of the program will occur outdoors in the courtyard at Barnstable High School. **For individuals only wanting to participate with the outdoor portion, please plan to arrive around 11:15 AM.**

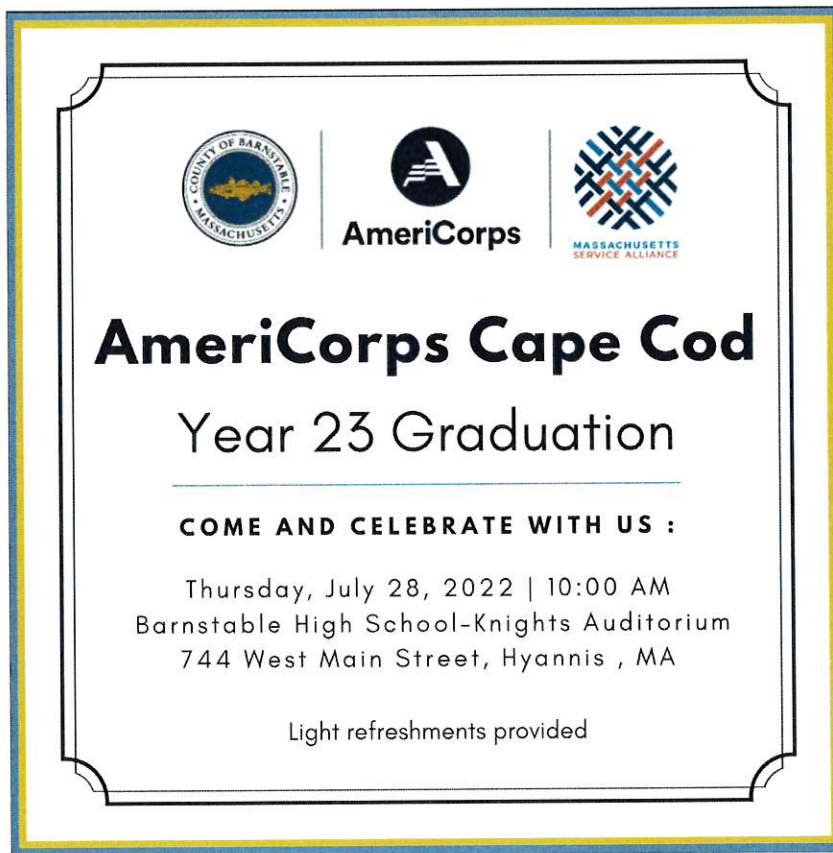





We look forward to celebrating with you!



Kat Garofoli

Program Manager | AmeriCorps Cape Cod

Barnstable County, Regional Government of Cape Cod

 Email katherine.garofoli@barnstablecounty.org |  Office (774) 314-2182
 3195 Main Street | P.O. Box 427 | Barnstable, MA 02630
 www.americorpscapedod.org

Robbin Kelley

From: Joe Powers
Sent: Tuesday, July 12, 2022 8:28 AM
To: Duncan Berry; Robbin Kelley
Cc: Don Howell; Harwich Historical Society; Meggan Eldredge; Danielle Delaney
Subject: RE: West Harwich Church Cemetery

Importance: High

Good morning Duncan:

Thank you for bringing this matter to my attention. I have copied Robbin Kelley, Cemetery Administrator, on this email and herein direct her to contact Mr. Cobb regarding the ownership and allowed use of the Baptist Church Cemetery located at Route 28 & Depot Street (as it is referenced on the town's website).

Good morning Robbin:

Please reach out to Mr. Cobb as requested by Mr. Berry and update this group once completed.

Thank you all,

Joe

Joseph F. Powers, ICMA-CM, MCPPO

Town Administrator
Town of Harwich
732 Main Street
Harwich, MA 02645
Office: (508) 430-7513
Mobile: (774) 801-8202

From: Duncan Berry [mailto:duncan@jduncanberry.com]
Sent: Tuesday, July 12, 2022 8:20 AM
To: Joe Powers <jpowers@town.harwich.ma.us>
Cc: Don Howell <donaldfhowell@gmail.com>; Harwich Historical Society <director@harwichhistoricalsociety.org>
Subject: West Harwich Church Cemetery

Joe:

This goes back to a pre-COVID discussion we had concerning public use of the West Harwich Baptist Church cemetery for Historical Society Tours.

Pastor John Cobb accosted a member of the Historical Society recently and was abusive about access to the cemetery.

This coming Saturday I will be giving another tour of that cemetery—which will feature artifacts, manuscripts, and photos of the deceased—and I would like to both avoid a public scene with him, and lay the matter to rest once and for all.

The Town maintains the cemetery and, as such, enjoys the prerogative of use and access—as you and Don Howell have stated unequivocally.

Would you please write him a one- or two-sentence letter to that effect so he is fully informed prior to Saturday's 11:30a tour?

John Cobb resides at 180 Belmont Road, West Harwich, MA 02671.

If you have any questions, please feel free to contact me on my cell: 774-722-0451.

Thank you, Joe!

Duncan

J. Duncan Berry, Ph. D.
duncan@jduncanberry.com



HARWICH CEMETERY COMMISSION

Office-100 Oak Street, Harwich 02645

Mail -732 Main Street, Harwich, 02645
rkelly@town.harwich.ma.us



July 13, 2022

John Cobb
180 Belmont Road
West Harwich, MA 02671

Mr. Cobb,

The members of the Harwich Historical Society will be hosting a tour of the West Harwich Baptist Cemetery on Saturday July 16, 2022. In 1948 an Act Authorizing the Town of Harwich to receive and administer the property of certain Cemetery Associations in the said Town. One of these is the Baptist Cemetery. The Town holds and maintain, these properties for cemetery purposes. This was passed at Town meeting on May 3, 1948. The Town has been maintaining the cemetery since, and the Town and its residents have the right to access and use this cemetery.

The Historical Society has requested that participant's park at the School House Parking lot.

If you have any questions feel free to contact me at 508-430-7549.

Sincerely,

Robbin M. Kelley,
Cemetery Administrator

1948 Chap. 0277. An Act Authorizing The Town Of Harwich To Receive And Administer The Property Of Certain Cemetery Associations In Said Town.

URI

<http://hdl.handle.net/2452/57577>

Collections

1948

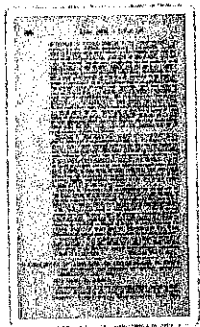

View/Open

 1948acts0277.txt (3.008Kb)

 1948acts0277.pdf (126.2Kb)

Date

1948

Author

Metadata

[Show full item record](#)

Date Accessioned

2010-12-03

Date Available

2010-12-03

Publisher

Boston: Secretary of the Commonwealth

LCSH Subject

Session Laws - Massachusetts

OCLC Number

ocm01696853

authorized to transact business in the commonwealth as surety, for the faithful performance of his duties, in such sum and upon such conditions as the board may require, and shall, subject to the approval of the board, appoint such assistants, agents and employees as the exercise and performance of his powers, rights and duties may require. He shall keep full and complete records of the doings of his office and shall render to the board, as often as it may require, a full report of all operations under his control during the period reported upon; and annually, and from time to time as required by the board, he shall make a synopsis of such reports for publication. He shall keep the board fully advised as to the needs of the town within the scope of his duties, and shall annually furnish to the board, not less than ten days prior to the expiration of the fiscal year of said town, a carefully prepared and detailed estimate in writing of the appropriations required during the next succeeding fiscal year for the proper exercise and performance of all said powers, rights and duties.

SECTION 4. The town may rescind all or any part of the action taken by it in pursuance of this act by a majority vote of the legal voters present and voting thereon by ballot at any town meeting held after three years following the annual town election at which this act becomes fully effective and at least thirty days before the annual town election next to be held after such meeting, and thereupon said town shall, at said next annual town election, nominate and elect such officers as are necessary to exercise and perform such of the powers, rights and duties transferred to the board under section two as are affected by said vote.

SECTION 5. This act shall be submitted for acceptance to the legal voters of said town at the biennial state election in the year nineteen hundred and forty-eight, in the form of the following question which shall be placed on the official ballot to be used in said town at said election: — "Shall an act passed by the General Court in the year nineteen hundred and forty-eight, entitled 'An Act authorizing the Town of Canton to establish a Board of Public Works exercising the powers of certain other Boards, Departments and Town Officers, and authorizing the Selectmen to act as said Board', be accepted?" If a majority of the votes cast in answer to such question is in the affirmative, this act shall become fully effective at the next annual town election; otherwise it shall be of no effect.

Approved May 3, 1948.

Chap. 277 AN ACT AUTHORIZING THE TOWN OF HARWICH TO RECEIVE AND ADMINISTER THE PROPERTY OF CERTAIN CEMETERY ASSOCIATIONS IN SAID TOWN.

Be it enacted, etc., as follows:

SECTION 1. Each of the following-named cemetery associations, situated in the town of Harwich, to wit: Baptist Cemetery, Smith Cemetery, Chase Cemetery, North Har-



wich Cemetery, Kelley Cemetery, Centre Cemetery, Harding Cemetery, Seth Eldridge Cemetery, Old Methodist Cemetery, End of the Pond Cemetery and South Harwich Cemetery, or any of them, hereinafter called associations, may, by deed duly executed, convey and transfer to said town, and said town is hereby authorized and empowered to receive, and thereafter to hold and maintain, but for cemetery purposes only, and subject to all rights heretofore existing in any burial lots, the real and personal property of the associations not subject to any trust, and thereupon, and upon the transfer of the trust funds as hereinafter provided, the associations shall be dissolved; and the cemeteries of the associations shall be and become public burial places, grounds or cemeteries.

SECTION 2. In so far as authorized by a decree of a court of competent jurisdiction and in compliance with the terms and conditions of such decree, said town may receive from the associations a conveyance and transfer of, and administer, all funds or other property held by the associations in trust for the perpetual care of the lots in the cemeteries and for other purposes, and also any property devised or bequeathed to the associations under the will of any person living at the time of said transfer or conveyance or under the will of any deceased person not then probated. Interest and dividends accruing on funds deposited in trust with any savings bank under authority of section thirty-seven or section thirty-eight of chapter one hundred and sixty-eight of the General Laws, or with any other banking institution, for the benefit of the associations, or of any lots in the cemeteries, may, after such conveyance, be paid by such bank or institution to the treasurer of said town; and upon such payment said treasurer shall use the same for the purposes of said trusts.

SECTION 3. All real and personal property and property rights, acquired by said town from the associations under authority of this act, shall be held and managed by said town in the same manner in which cities and towns are authorized by law to hold and manage property for cemetery purposes; provided, that all rights which any persons have acquired in the cemeteries of the associations or any lots therein shall remain in force to the same extent as if this act had not been passed and such transfer had not occurred. The records of the associations shall be delivered to the clerk of said town and such clerk may certify copies thereof.

SECTION 4. This act shall take full effect upon its acceptance by a majority of the registered voters of the town of Harwich voting thereon at a regular or special town meeting held in the current year, but not otherwise.

Approved May 3, 1948.



TOWN OF
HARWICH
MASSACHUSETTS



1948 Annual Reports

ater mains where
ncome from such
talling.

ill appropriate a
ent Construction
appurtenances in
as the Board of
Also, determine
led for by taxa-
the treasury, or

ote to raise and
be used for the
n East Harwich,
such sums as are
1 of Waterways.

ote to raise and
be used for the
Parking lot at
der the direction
hereon.

ote to extend
oad, and to act

ote to rescind
l Town Meeting
required to enter
six percent in-
sion to her home
on.

ote to raise and
llars (\$1200) to
deemed proper
t Annual Town

ote to raise and
re care of drain-
at Cross and
t fully thereon.

Article 60. To see if the Town will vote to accept Chapter 227 of the Acts of the General Court for 1948, as amended, concerning certain cemetery associations in the Town of Harwich, and to act fully thereon.

Article 61. To see if the Town will vote to increase the wage for Town labor to one dollar (\$1.00) per hour, and to act fully thereon.

Article 62. To see if the Town will vote to instruct the Moderator to appoint a committee of not less than five to study and consider the Town By-Laws; to change, amend, revoke or add to and to report its recommendations at the next annual meeting, and to act fully thereon.

Article 63. To see if the Town will vote to expend the refunded Dog Tax for the support of Brooks Free Library, and to act fully thereon.

Article 64. To see if the Town will authorize the School Committee to dispose of one old gas stove no longer in use at the High School.

Article 65. To see if the Town will vote to raise and appropriate the sum of five thousand dollars (\$5000) for the School Committee to use for the purpose of developing a playing field at the High School.

Article 66. To see if the Town will vote to erect a suitable tablet on the old High School building to commemorate its history and uses, and to raise and appropriate a sum of money sufficient for the purpose.

Article 67. To see if the Town will appropriate from available funds the sum of \$1,000.00 for the purpose of protecting the Town's interest in the continuance of Railroad Transportation facilities and to appoint a committee of not less than three members with authority to approve the disbursement of such funds, said Committee to be appointed by the Moderator.

Article 68. To see if the Town will vote to make the so-called Schoolhouse yard in Harwichport a public parking lot and act fully thereon.

Article 69. To see if the Town will vote to transfer the following unexpended balances of special appropriations to Surplus Revenue:

1949
ANNUAL REPORTS

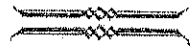

TOWN OF HARWICH
MASSACHUSETTS

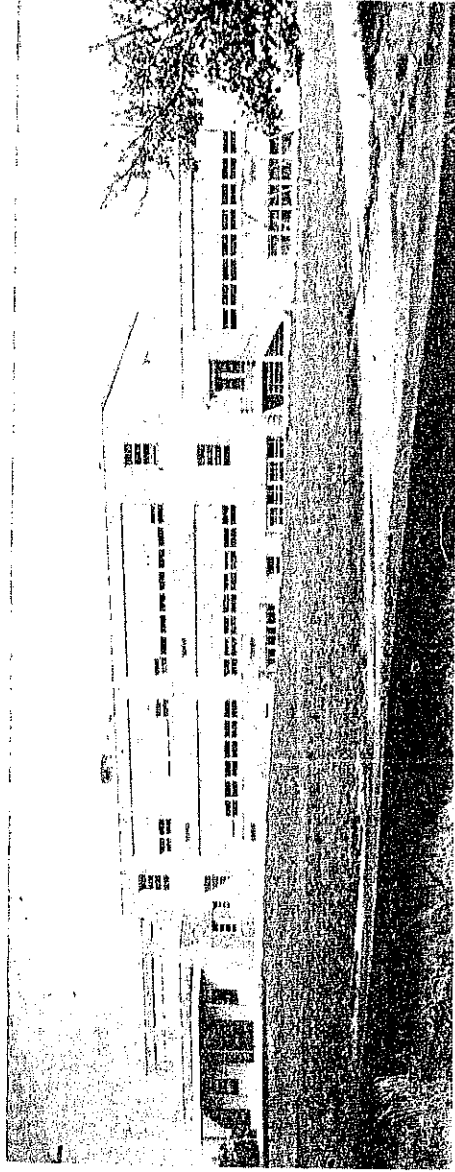

PHOTO BY SIDNEY P. MOODY

NEW ELEMENTARY SCHOOL BUILDING

Article 55. To see if the Town will vote to raise and appropriate a sufficient sum of money to be used for the improvement and hardening of the Town Parking lot at the East end of Long Pond, to be used under the direction of the Park Commissioners and act fully thereon.

Accepted and adopted. Raised and appropriated \$500.00

Article 56. To see if the Town will vote to extend the water mains on Saquatucket Bluffs Road, and to act fully thereon.

Indefinitely postponed.

Article 57. To see if the Town will vote to rescind the action taken on Article 3 at a Special Town Meeting, May 24, 1946, whereby Miss Lucy Ginn be required to enter in a contract with the Town guaranteeing six percent income on the cost of a short two inch extension to her home on Division Street, and to act fully thereon.

Indefinitely postponed.

Article 58. To see if the Town will vote to raise and appropriate the sum of twelve hundred dollars (\$1200) to plant shade trees along the Town Roads as deemed proper by the Committee, established at the last Annual Town Meeting, and to act fully thereon.

Indefinitely postponed.

Article 59. To see if the Town will vote to raise and appropriate a sufficient sum of money to take care of drainage of excessive water from heavy rains at Cross and Pleasant Streets in Harwichport, and to act fully thereon.

Accepted and adopted as read. Raised and appropriated \$1,000.00.

Article 60. To see if the Town will vote to accept Chapter 227 of the Acts of the General Court for 1948, as amended concerning certain cemetery associations in the Town of Harwich, and to act fully thereon.

It was moved by Oscar J. Cahoon, and duly seconded that: The Town vote to accept the provision of Chapter 227 of the Acts of the General Court of 1948, as amended by Chapter 2 of the Acts of the General Court of 1949. This motion was carried without opposition.

Article 61. the wage for hour, and to a

Accepted a Town labor or

Article 62. the Moderator five to study change, amen recommendati- act fully there

Accepted a tee appointed Oscar J. Cah Snow.

Article 63. the refunded Library, and t

Accepted an

Article 64. School Comm longer in use &

Accepted a for \$1.00 the Church.

Article 65. appropriate tl for the School veloping a pl

Accepted a thousand doll

Article 66. suitable tablet memorate its priate a sum

Accepted a thirty-five dol ated for this

Chat with an expert O

Connect One-on-One with a Technic Minutes.

JustAnswer

Fri 15 Jul **MA WEST HARWICH 02671**
Out for Delivery

MA WEST HARWICH 02671
Arrived at Post Office

Thu 14 Jul **PROVIDENCE RI DISTRIBUTION CENTER**
Departed USPS Regional Facility

Wed 13 Jul **PROVIDENCE RI DISTRIBUTION CENTER**
Arrived at USPS Regional Facility

MA WEST HARWICH 02671
Departed Post Office

MA WEST HARWICH 02671
USPS in possession of item

Get Notifications

Parcel location

Show parcel on a map

USPS rating



2.44 over 18443 votes

Show USPS reviews

WhatsApp

Gmail

Email App

Facebook

Print



WEST HARWICH
216 ROUTE 28
WEST HARWICH, MA 02671-9998
(800)275-8777

07/13/2022 02:55 PM

Product	Qty	Unit Price	Price
First-Class Mail® Letter	1		\$0.60
West Harwich, MA 02671 Weight: 0 lb 1.00 oz Estimated Delivery Date Fri 07/15/2022			
Certified Mail®			\$4.00
Tracking #: 7020245000017478630			
Total			\$4.60

7020 2450 0000 1747 8630

U.S. Postal Service™
CERTIFIED MAIL® RECEIPT
Domestic Mail Only

For delivery information, visit our website at www.usps.com

West Harwich, MA 02671

OFFICIAL USE

Certified Mail Fee	\$4.00
Extra Services & Fees (check box, add fee as appropriate)	
<input type="checkbox"/> Return Receipt (hardcopy)	\$0.00
<input type="checkbox"/> Return Receipt (electronic)	\$0.00
<input type="checkbox"/> Certified Mail Restricted Delivery	\$0.00
<input type="checkbox"/> Adult Signature Required	\$0.00
<input type="checkbox"/> Adult Signature Restricted Delivery	\$0.00
Postage	\$0.60
Total Postage and Fees	\$4.60

Sent To: **John Cobb**
Street and Apt. No., or PO Box No.: **100 Belmont Rd**
City, State, ZIP+4®: **West Harwich, MA 02671**

PS Form 3800, April 2015 PSN 7530-02-000-9047 See Reverse for Instructions

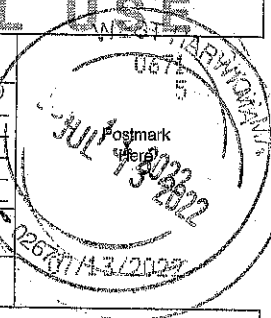

Thank you for your business.

Tell us about your experience.
Go to: <https://postalexperience.com/Pos>
or scan this code with your mobile device,



or call 1-800-410-7420.

UFN: 248959-0671
Receipt #: 840-50280144-1-3521540-2
Clerk: 5

Robbin Kelley

From: Meggan Eldredge
Sent: Tuesday, June 14, 2022 6:15 PM
To: Robbin Kelley
Subject: RE: Veterans memorial circle
Attachments: Hamco attachment A.PDF; Hamco Contract for signatures.doc; Farrell Attachment A.PDF; Farrell Contract for signatures.doc; POST Procurement Checklist.docx

Hi Robbin,

The next step is getting contracts signed. I have attached two contracts (one for the poles and one for the electrical work). Please reach out to each contractor and let them know we have accepted their bid and to review/sign the contracts-be sure to include the attachments for each individual contract. If they have questions about the contracts, let me know and we may be able to make adjustments.

Once signed, they will be signed by Joe. You will fill out the "post procurement checklist" and submit them with the signed contracts (attached).

You will get the liability insurance certificates as outlined in the contracts and then you can give the go-ahead to start the work.

Let me know if you have any questions!

Meggan

From: Robbin Kelley
Sent: Monday, June 13, 2022 10:31 AM
To: Meggan Eldredge <meldredge@town.harwich.ma.us>
Subject: RE: Veterans memorial circle

Meggan

The flag pole came in at \$15,489 and Farrell Electric was 36,525 so a total of 52,014 and the total for CPC Award was 48,385 for a difference of \$3,629.

We have funds to take overage out of the cemetery revolving account.

Please let me know how we can proceed.

Robbin Marie Kelley
Cemetery Administrator
Town of Harwich
Office: 100 Oak Street
Mailing: 732 Main Street
Harwich, MA 02645
Phone 508-430-7549

From: Meggan Eldredge
Sent: Wednesday, June 1, 2022 2:41 PM
To: Robbin Kelley <rkelly@town.harwich.ma.us>
Subject: Veterans memorial circle

Hi Robbin,

I only received the one bid for the electric work at Evergreen. Please let me know if you would like to proceed.

Also, please let me know if you had any interest on the purchase of the flag poles.

Meggan M. Eldredge
Assistant Town Administrator
Town of Harwich
732 Main Street
Harwich, MA 02645
508-430-7513 ext. 3344
meldredge@town.harwich.ma.us
www.harwich-ma.gov

FARRELL ELECTRIC, INC.

ATTACHMENT A

Quote

P O BOX 253
 NORTH EASTHAM, MA 02651

Date	Quote #
5/24/2022	1067A

Name / Address
HARWICH CEMETERY COMMISSION ATTN: MEGGAN ELDREDGE 732 MAIN ST HARWICH, MA 02645

Rep	Project

Description	Qty	Total
EVERGREEN CEMETERY EAST HARWICH MA		
TO INSTALL 1100 FT OF 2 INCH PVC CONDUIT FROM EXISTING POWER PANEL TO NEW 6 CIRCUIT OUTDOOR PANEL MOUNTED ON WOODEN PRESSURE TREATED PEDESTAL NEAR GAZEBO. INCLUDES INSTALLING 3 HANDHOLES EVENLY SPACED APART ALONG RUN. INCLUDES MOLING 2 INCH PIPE UNDER DRIVEWAY TO REACH MIDDLE OF ISLAND. INSTALL 2/0 ALUMINUM TRIPLEX IN 2 INCH CONDUIT FROM EXISTING PANEL TO NEW PANEL. INCLUDES EXCAVATION AND BACKFILLING. INCLUDES LOAMING AND SEEDING ALL DISTURBED AREAS. PRICE INCLUDES TOWN ELECTRICAL PERMIT FEE		
3 MEN TRUCKS AND EQUIPMENT 5 DAYS		21,250.00
MATERIALS		15,275.00
*** ALL WORK DONE TO SPECIFICATIONS THAT WERE PROVIDED BY TOWN IN BID PAPERWORK ***INCLUDES PREVAILING WAGE RATE PAYMENTS TO ALL WORKERS ON JOB		
Total		\$36,525.00

ATTACHMENT A

Hamco Flagpoles & Flags

508-778-6822

capecodflagpole@gmail.com | www.hamcoflagpoles.com



RECIPIENT:

Evergreen Cemetery

273 Queen Ann Rd.
Harwich, Ma 02645

SERVICE ADDRESS:

1403 Orleans Rd
Harwich, MA 02645

Quote #365

Sent on Jun 10, 2022

Total \$15,489.00

PRODUCT / SERVICE	DESCRIPTION	QTY.	UNIT PRICE	TOTAL
35I Aeolus Series	35' Standard Duty/Commercial Internal Halyard Gold anodized aluminum ball - Polyester halyard* Wire core retaining ring Vinyl covered counterweight Stainless steel and nylon internal cam cleat - hand hole door with security system Security driver to access hand hole Composite flash collar Brass snaps with vinyl covers Internal stationary single sheave fiberglass truck Fiberglass ground sleeve	1	\$2,250.00	\$2,250.00
30I Aeolus Series	30' Standard Duty/Commercial Internal Halyard Gold anodized aluminum ball - Polyester halyard* Wire core retaining ring Vinyl covered counterweight Stainless steel and nylon internal cam cleat - hand hole door with security system Security driver to access hand hole Composite flash collar Brass snaps with vinyl covers Internal stationary single sheave fiberglass truck Fiberglass ground sleeve	6	\$1,750.00	\$10,500.00
Aeolus/Apollo 20'-30' Series/w sleeve Installation	Standard Ground Set	6	\$425.00	\$2,550.00*
5 X 8 Service Flag	Annin	1	\$79.00	\$79.00
6 X 10 Annin Ny-Glo US Flag	Embroidered Stars; Color Fast Nylon	1	\$110.00	\$110.00*

Robbin Kelley

From: Raymond Leach <RLeach@coldspringusa.com>
Sent: Monday, July 18, 2022 10:02 AM
To: Robbin Kelley
Subject: RE: Flagpole Base

Hello Robbin,
Hope all is well. I just wanted to follow up on the granite flagpole base to see if you are still interested?
Thank you and have a great week!

RAYMOND LEACH | Regional Sales Manager

Coldspring

17482 Granite West Road | Cold Spring, MN 56320
T: 800-328-5040 | M: 989-798-3333
www.coldspringusa.com | rleach@coldspringusa.com
Follow us on [Twitter](#) | [Facebook](#)

This communication is intended only for the recipient(s) named above, may be confidential and/or legally privileged, and must be treated as such in accordance with state and federal laws. If you are not the intended recipient, you are hereby notified that any use of this communication, or any of its contents, is prohibited. If you have received this communication in error, please return it to the sender and delete the message from your computer system.

From: Robbin Kelley [mailto:rkelley@town.harwich.ma.us]
Sent: Thursday, June 30, 2022 8:15 AM
To: Raymond Leach
Subject: RE: Flagpole Base

CAUTION: This email originated from outside Coldspring. Verify the legitimacy before clicking links or opening attachments.

Raymond

I am on vacation will send off to my commissioners and get back to you.

Robbin

From: Raymond Leach [mailto:RLeach@coldspringusa.com]
Sent: Wednesday, June 29, 2022 1:09 PM
To: Robbin Kelley <rkelley@town.harwich.ma.us>
Subject: Flagpole Base

Hello Robbin,
Attached is a sketch of the granite flag pole base. Estimating said the price including freight will be around \$42,000. Please let me know if you would like to proceed and I will get you an official quote. We can still make your November time frame if we get the order in right away.
Thank you,

RAYMOND LEACH | Regional Sales Manager

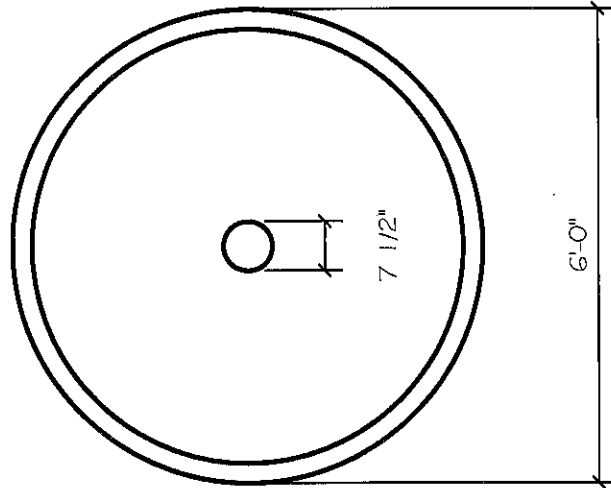

PLAN VIEW

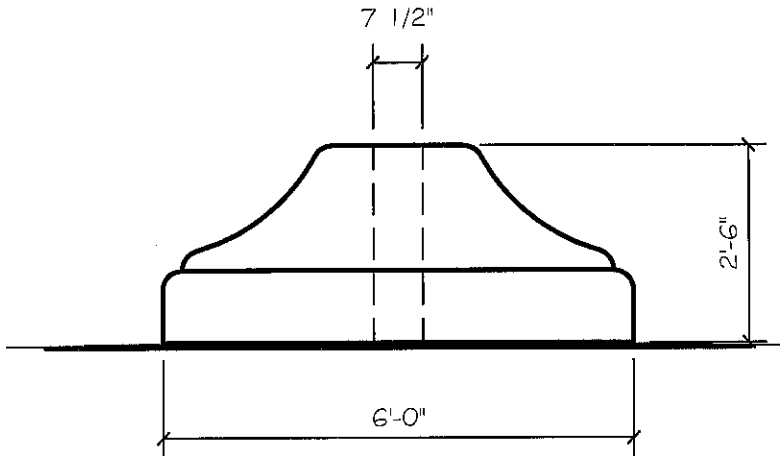

ELEVATION

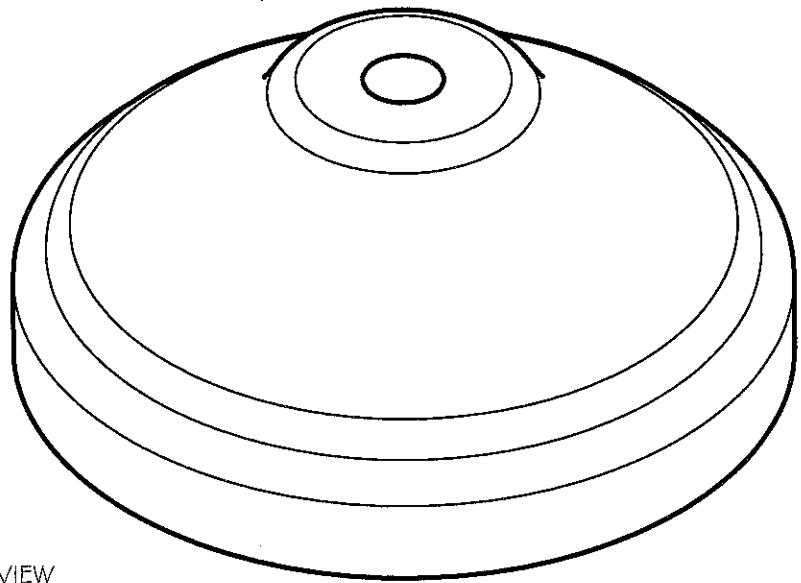

ISOMETRIC VIEW

This design is property of ColdSpring and protected by applicable copyright laws. Unauthorized use or duplication is prohibited. This design is for concept only.

PROJECT: FLAG POLE BASE

LOCATION: HARWICH, MA

DESIGN: 1024583

SCALE: NTS



COLDSPRING

WWW.COLDSPRINGUSA.COM

DESIGNED BY: JUSTIN PIEPENBURG

DATE: 6/28/22

This design is intended for conceptual purposes only. Renderings may not accurately represent stone shade, natural variegation, or final carving and lettering. All carving and lettering will be finalized per contract prior to fabrication.

PROCUREMENT CHECKLIST & APPROVAL FORM

STAFF LEAD: Robbin Kelley

DEPARTMENT: Cemetery Department

FUNDING SOURCE: Cemetery Revolving Account

Appropriated amount: \$32,000.00

Estimated cost: _____ Actual cost: _____

PROCUREMENT METHOD:

30B

PURCHASE DESCRIPTION:

Purchase descriptions should contain the following components (see document on purchase descriptions):
Description of supplies or services required; quantities required; schedule for performance and delivery terms.

The following software require for Evergreen Mapping and Software.
Electronic import all cemetery records in Microsoft Access: Evergreen Cemetery, The ability for Harwich Cemetery staff to add additional data entry of smaller cemeteries within the Town of Harwich to be accessed by Mobile App.
Mapping of Evergreen Cemeterys inventory on satellite maps showing the location of each lot and color coding inventory status.
Create Evergreen Cemetery available property listing page on Town Cemeterys website and Mobile App and track visitors engagement and inquiries.
Fully integrated 360 degree visual image within the inventory maps and sales applications.
Onsite collection of 360 degree images of cemetery roadways, walkways and general property boundaries with roughly a 50 x 50 foot layout. To achieve the desired density of images throughout Evergreen Cemetery, a minimum of 1,000 images are required.
Create a visual application and/or player directly on the cemetery website that showcases featured locations of the cemetery and all its 360 degree images for each proposed cemeteries.
Creation of Mobile Sales App for cemetery staff to search records and identify available property on map with integrated 360 views.

PROCUREMENT MAY PROCEED ONLY IF SIGNATURES PROVIDED BELOW CEMETERY REVOLVING ACCT.

Funds Available: Finance Director: _____

DocuSigned by:
Wendy Tulloch

Account # _____

D4BBAA4188474E3...

Approved to proceed: Town Administrator or Designee: _____

DocuSigned by:
Joseph F. Powers

0623C0C5799644E...

Software require for Evergreen Mapping and Software.

Evergreen Cemetery, 40 Cemetery Road & 1403 Orleans Road, Harwich, MA. (20 acres)

Requests for project to Cemetery Department, 732 Main Street, Harwich, MA 02645





HARWICH CEMETERY COMMISSION

Office-100 Oak Street, Harwich 02645

Mail -732 Main Street, Harwich, 02645

rkelly@town.harwich.ma.us



The following software require for Evergreen Mapping and Software.

Electronic import all cemetery records in Microsoft Access: Evergreen Cemetery, The ability for Harwich Cemetery staff to add additional data entry of smaller cemeteries within the Town of Harwich to be accessed by Mobile App.

Mapping of Evergreen Cemetery's inventory on satellite maps showing the location of each lot and color coding inventory status.

Create Evergreen Cemetery available property listing page on Town Cemetery's website and Mobile App and track visitors' engagement and inquiries.

Fully integrated 360 degree visual image within the inventory maps and sales applications.

Onsite collection of 360 degree images of cemetery roadways, walkways and general property boundaries with roughly a 50 x 50 foot layout. To achieve the desired density of images throughout Evergreen Cemetery, a minimum of 1,000 images are required. Spring to early fall Season to be determined by Cemetery Administrator

Create a visual application and/or player directly on the cemetery website that showcases featured locations of the cemetery and all its 360 degree images for each proposed cemeteries.

Creation of Mobile Sales App for cemetery staff to search records and identify available property on map with integrated 360 views.

Public Mobile App publish an interactive satellite map on the each cemetery enabling visitors to search burials, tours, inventory options, 360 images and memorial pages which included GPS navigation to each location.

Memorial pages for each record, allowing the visitors and/or staff to add pictures, videos and memories to be verified and/or approved by Cemetery Staff.

Training for staff on sales tools and aftercare on properties to allow follow-up with new clients.

Press Release to launch to public.

Including all Annual Costs; including but not limited to Hosting, Backups, Support 365 days a year, Licenses and Fees. **(First year costs to be included in Total Cost)** (Additional 2 years hosting costs to be on separate line item)

Evergreen Cemetery, 40 Cemetery Road & 1403 Orleans Road, Harwich, MA. (20 acres)

If you have any questions feel free to call me at 508-430-7549.

Robbin M Kelley
Cemetery Administrator.



HARWICH CEMETERY COMMISSION

Office-100 Oak Street, Harwich 02645

Mail -732 Main Street, Harwich, 02645

rkelley@town.harwich.ma.us



July 27, 2022

Community Preservation Committee:
Updates on Open Articles:

HISTORIC:

Article #32 TM 2020 – Pine Grove Cemetery Gravestone Conservation. Appropriated Amount: \$75,000.00.

Was awarded to Village Green Restoration, Inc. from East Falmouth July 8, 2021.

Has been completed \$42,900 report and invoice sent to CPC and Jan email's.

Money to be returned to the CPC is \$32,100.00

RECREATION:

Article #29 TM 2021 - Phase I of II for Veterans Memorial Circle at Evergreen Cemetery. Appropriated Amount: \$48,385.00.

Install flags, lighting and related electrical service,

Contracts have been awarded to the following

Farrell Electric \$36,525.00 installation of Electrical Service to Lighting at Circle.

Hamco Flagpoles & Flags \$15,489.00 Flag Poles and Flags

Total of 52,014.00 (\$48,385.00 CPC & \$8,629.00 Cemetery Revolving Account)

HISTORIC:

Article #31 TM 2022 - East Harwich Union Cemetery Gravestone Conservation.

\$118,800.00. Procurement Checklist has been approved and has gone out to BID, the BID opening is August 10, 2022 at Town Hall.

Next Year Expected CPC Articles:

HISTORIC: Phase II Veterans Memorials at Evergreen Cemetery. Revolutionary War and Civil War Memorials. Will be finalizing the names to be place and requesting price quotes on cost for memorials.

Robbin Kelley
Cemetery Administrator

PROCUREMENT CHECKLIST & APPROVAL FORM

STAFF LEAD: Robbin Kelley

DEPARTMENT: Cemetery Administrator

FUNDING SOURCE: CPC Article #31 TM2022

Appropriated amount: \$118,800.00

Estimated cost: _____ Actual cost: _____

PROCUREMENT METHOD:

30B

PURCHASE DESCRIPTION:

Purchase descriptions should contain the following components (see document on purchase descriptions):
Description of supplies or services required; quantities required; schedule for performance and delivery terms.

East Harwich Union Cemetery Gravestone Preservation Project

45 Monuments in need of repair, due to fractures or damage from falling over and /or previous failed repairs.
158 Reset or New Foundations 108 headstones, 2 corner markers, 48 footstones either need to be reset or foundation repair. Monuments are leaning and are in need of treatment to be reset so that they will not topple over and to prevent future degradation.
New bases will be made where required.
265 memorials will be cleaned and consolidated includes headstone and footstones.
Slate will not be consolidated but will be cleaned of biologicals.
Before and after digital photographs for each marker.
Supporting digital documentation.

ATM22
CPC Article #31
\$118,800

PROCUREMENT MAY PROCEED ONLY IF SIGNATURES PROVIDED BELOW

Funds Available: Finance Director: Wendy Fulloch Account # _____
DocuSigned by: D49BAA4188474E3...

Approved to proceed: Town Administrator or Designee: Joseph F. Powers
DocuSigned by: 0623C0C5788644E...

PROCUREMENT CHECKLIST & APPROVAL FORM

STAFF LEAD: Robbin Kelley DEPARTMENT: Cemetery Department

FUNDING SOURCE: Community Preservation Article #29 TM 2021

Appropriated amount: \$16,000.00 Estimated cost: _____ Actual cost: _____

PROCUREMENT METHOD:

30B

PURCHASE DESCRIPTION:

Purchase descriptions should contain the following components (see document on purchase descriptions):
Description of supplies or services required; quantities required; schedule for performance and delivery terms.

Installation of Flag Poles at Veterans Memorial Circle in Evergreen Cemetery

Installation of American Flag Pole 35' Standard Duty/Commercial Internal Halyard (Gold anodized aluminum ball -Polyester halyard, Wire core retaining ring, Vinyl covered counterweight, Stainless steel and nylon internal cam cleat - handhole door with security system Security driver to access hand hole, Composite flash collar, Brass snaps with vinyl covers, Internal stationary single sheave fiberglass truck, Fiberglass ground sleeve) in the center of circle.

Surrounded by 6 Service Flags Poles 30' Standard Duty/Commercial Internal Halyard (Gold anodized aluminum ball -Polyester halyard, Wire core retaining ring, Vinyl covered counterweight, Stainless steel and nylon internal cam cleat - handhole door with security system Security driver to access hand hole, Composite flash collar, Brass snaps with vinyl covers, Internal stationary single sheave fiberglass truck, Fiberglass ground sleeve) for each branch of the military. Army, Navy, Air Force, Marines, Coast Guard and Space Force includes flags.

Service Flags 5 x 8 and American Flag 6 x 10

80271292/62129
6

PROCUREMENT MAY PROCEED ONLY IF SIGNATURES PROVIDED BELOW

Funds Available: Finance Director: _____
DocuSigned by: Carol Coppola Account # _____
48C32039D33D434...

Approved to proceed: Town Administrator or Designee: _____
DocuSigned by: Joseph F. Powers
0623C0C5799644E...

EVERGREEN MEMORIAL CIRCLE FLAG'S

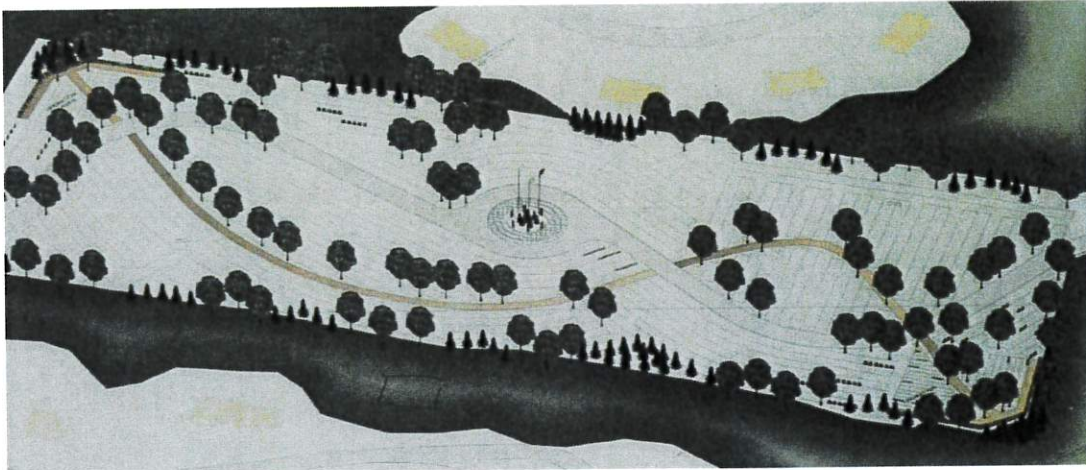

Placement of the flags in the circle will be marked out by Cemetery Department.

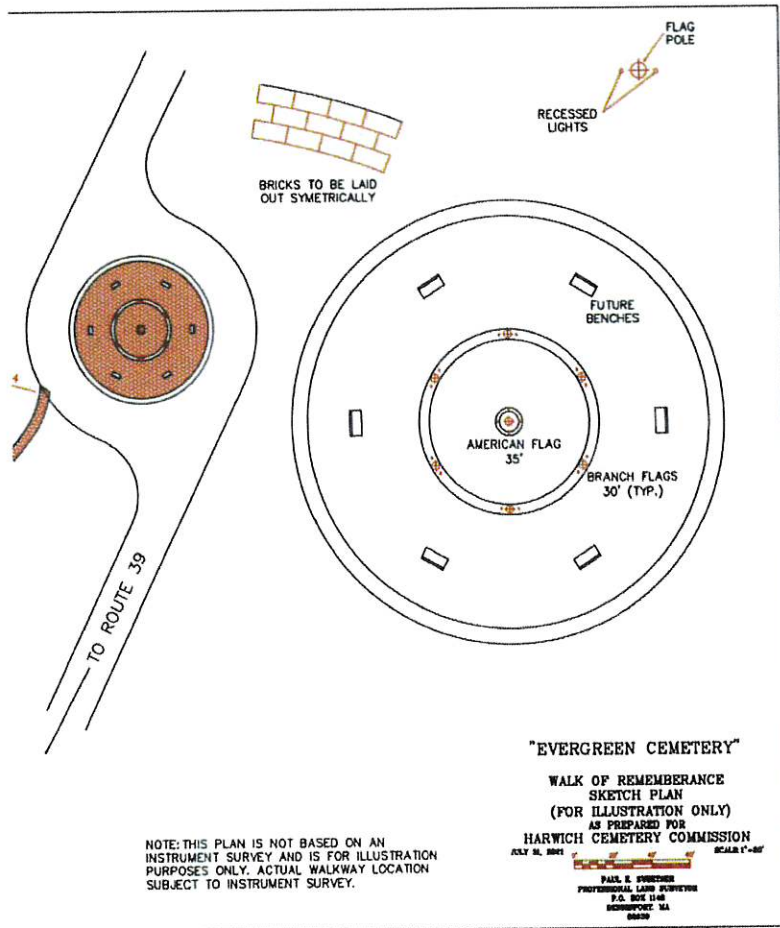

ATTACHMENT A

Hamco Flagpoles & Flags

508-778-6822

capecodflagpole@gmail.com | www.hamcoflagpoles.com



RECIPIENT:

Evergreen Cemetery

273 Queen Ann Rd.
Harwich, Ma 02645

SERVICE ADDRESS:

1403 Orleans Rd
Harwich, MA 02645

Quote #365	
Sent on	Jun 10, 2022
Total	
	\$15,489.00

PRODUCT / SERVICE	DESCRIPTION	QTY.	UNIT PRICE	TOTAL
35I Aeolus Series	35' Standard Duty/Commercial Internal Halyard Gold anodized aluminum ball - Polyester halyard* Wire core retaining ring Vinyl covered counterweight Stainless steel and nylon internal cam cleat - hand hole door with security system Security driver to access hand hole Composite flash collar Brass snaps with vinyl covers Internal stationary single sheave fiberglass truck Fiberglass ground sleeve	1	\$2,250.00	\$2,250.00
30I Aeolus Series	30' Standard Duty/Commercial Internal Halyard Gold anodized aluminum ball - Polyester halyard* Wire core retaining ring Vinyl covered counterweight Stainless steel and nylon internal cam cleat - hand hole door with security system Security driver to access hand hole Composite flash collar Brass snaps with vinyl covers Internal stationary single sheave fiberglass truck Fiberglass ground sleeve	6	\$1,750.00	\$10,500.00
Aeolus/Apollo 20'-30' Series/w sleeve Installation	Standard Ground Set	6	\$425.00	\$2,550.00*
5 X 8 Service Flag	Annin	1	\$79.00	\$79.00
6 X 10 Annin Ny-Glo US Flag	Embroidered Stars; Color Fast Nylon	1	\$110.00	\$110.00*

Hamco Flagpoles & Flags

508-778-6822

capecodflagpole@gmail.com | www.hamcoflagpoles.com



* Non-taxable

You may pay your deposit securely online or please mail a check payable to Hamco Flagpoles
32 Cranberry Ln.
Centerville, MA 02632
Thank you for choosing Hamco Flagpoles and flags!

*We will beat any competitor quote by 5% (applies to Zeus/PLP Flagpoles)

Subtotal	\$15,489.00
Exempt (0.0%)	\$0.00
Total	\$15,489.00

PROCUREMENT CHECKLIST & APPROVAL FORM

STAFF LEAD: Robbin Kelley DEPARTMENT: Cemetery Department

FUNDING SOURCE: Community Preservation Article #29 TM 2021

Appropriated amount: \$32,385.00 Estimated cost: _____ Actual cost: _____

PROCUREMENT METHOD:

30, 39M Project (public works)

PURCHASE DESCRIPTION:

Purchase descriptions should contain the following components (see document on purchase descriptions):
Description of supplies or services required; quantities required; schedule for performance and delivery terms.

EVERGREEN VETERANS MEMORIAL CIRCLE LIGHTING

GENERAL DESCRIPTION

Provide labor and materials to install a new sub-panel for power and lighting located at Evergreen Cemetery in East Harwich, Massachusetts. Underground flag pole lights (LED) and waterproof electrical power outlet within circle.

GENERAL PROVISIONS

Excavate approximately 1100 feet of earth and install conduit and wire from power panel to new sub-panel. (Installation of conduit beginning at 1403 Orleans Road power panel running between paved roadway and existing waterline)

Install hand hole pull boxes where required ensuring the top of the box is level with the ground. The wire shall be sized to maintain single phase 120 volts and 30 amps.

The new panel will be rated for exterior use with minimal room for expansion. It shall be mounted to a frame provided by the contractor.

After the installation of the conduit the trench will be backfilled, loamed and seeded.

80271292/620021

PROCUREMENT MAY PROCEED ONLY IF SIGNATURES PROVIDED BELOW

Funds Available: Finance Director: Carol Coppola Account # _____
DocuSigned by: 48C32039D33D434...

Approved to proceed: Town Administrator or Designee: Joseph F. Powers
DocuSigned by: 0623C0C5799644E...

Evergreen Electrical Service for Veterans Memorial Circle



Service will run along the roadway in between edge of road and irrigation system.

FARRELL ELECTRIC, INC.

ATTACHMENT A

Quote

P O BOX 253
 NORTH EASTHAM, MA 02651

Date	Quote #
5/24/2022	1067A

Name / Address
HARWICH CEMETERY COMMISSION ATTN: MEGGAN ELDREDGE 732 MAIN ST HARWICH, MA 02645

Rep	Project

Description	Qty	Total
EVERGREEN CEMETERY EAST HARWICH MA		
TO INSTALL 1100 FT OF 2 INCH PVC CONDUIT FROM EXISTING POWER PANEL TO NEW 6 CIRCUIT OUTDOOR PANEL MOUNTED ON WOODEN PRESSURE TREATED PEDESTAL NEAR GAZEBO. INCLUDES INSTALLING 3 HANDHOLES EVENLY SPACED APART ALONG RUN. INCLUDES MOLING 2 INCH PIPE UNDER DRIVEWAY TO REACH MIDDLE OF ISLAND. INSTALL 2/0 ALUMINUM TRIPLEX IN 2 INCH CONDUIT FROM EXISTING PANEL TO NEW PANEL. INCLUDES EXCAVATION AND BACKFILLING. INCLUDES LOAMING AND SEEDING ALL DISTURBED AREAS. PRICE INCLUDES TOWN ELECTRICAL PERMIT FEE		
3 MEN TRUCKS AND EQUIPMENT 5 DAYS		21,250.00
MATERIALS		15,275.00
*** ALL WORK DONE TO SPECIFICATIONS THAT WERE PROVIDED BY TOWN IN BID PAPERWORK ***INCLUDES PREVAILING WAGE RATE PAYMENTS TO ALL WORKERS ON JOB		
Total		\$36,525.00

AGREEMENT FOR TOWN OF HARWICH

The following provisions shall constitute an Agreement between the Town of Harwich, acting by and through its Board of Selectmen, hereinafter referred to as "Town," and Farrell Electric, Inc. with an address of PO Box 253, North Eastham, MA 02651 hereinafter referred to as "Contractor", effective as of the 27 day of June, 2022. In consideration of the mutual covenants contained herein, the parties agree as follows:

ARTICLE 1: SCOPE OF WORK:

The Contractor shall perform all work and furnish all services necessary to provide the Town with electrical work at Veterans Memorial Circle in Evergreen Cemetery including the scope of services set forth in Attachment A.

ARTICLE 2: TIME OF PERFORMANCE:

The Contractor shall complete all work and services required hereunder commencing upon contract execution and completing work before November 1, 2022.

ARTICLE 3: COMPENSATION:

The Town shall pay the Contractor for the performance of the work outlined in Article 1 above the contract sum of \$36,525.00. The Contractor shall submit monthly invoices to the Town for services rendered, which will be due 30 days following receipt by the Town.

ARTICLE 4: CONTRACT DOCUMENTS:

The following documents form the Contract and all are as fully a part of the Contract as if attached to this Agreement or repeated herein:

1. This Agreement.
2. Amendments, or other changes mutually agreed upon between the parties.
3. All attachments to the Agreement.

In the event of conflicting provisions, those provisions most favorable to the Town shall govern.

ARTICLE 5: CONTRACT TERMINATION:

The Town may suspend or terminate this Agreement by providing the Contractor with ten (10) days written notice for the reasons outlined as follows:

1. Failure of the Contractor, for any reason, to fulfill in a timely and proper manner its obligations under this Agreement.
2. Violation of any of the provisions of this Agreement by the Contractor.
3. A determination by the Town that the Contractor has engaged in fraud, waste, mismanagement, misuse of funds, or criminal activity with any funds provided by this Agreement.

Either party may terminate this Agreement at any time for convenience by providing the other party written notice specifying therein the termination date which shall be no sooner than thirty (30) days from the issuance of said notice. Upon receipt of a notice of termination from the Town, the Contractor shall cease to incur additional expenses in connection with the Agreement. Upon such termination, the Contractor shall be entitled to compensation for all satisfactory work completed prior to the termination date as determined by the Town. Such payment shall not exceed the fair value of the services provided hereunder.

ARTICLE 6: INDEMNIFICATION:

The Contractor shall defend, indemnify and hold harmless the Town and its officers, agents, and all employees from and against claims arising directly or indirectly from the contract. Contractor shall be solely responsible for all local taxes or contributions imposed or required under the Social Security, Workers' Compensation, and income tax laws. Further, the Contractor shall defend, indemnify and hold harmless the Town with respect to any damages, expenses, or

claims arising from or in connection with any of the work performed or to be performed under this Agreement. This shall not be construed as a limitation of the Contractor's liability under the Agreement or as otherwise provided by law.

ARTICLE 7: AVAILABILITY OF FUNDS:

The compensation provided by this Agreement is subject to the availability and appropriation of funds.

ARTICLE 8: APPLICABLE LAW:

The Contractor agrees to comply with all applicable local, state and federal laws, regulations and orders relating to the completion of this Agreement. This Agreement shall be governed by and construed in accordance with the law of the Commonwealth of Massachusetts.

ARTICLE 9: ASSIGNMENT:

The Contractor shall not make any assignment of this Agreement without the prior written approval of the Town.

ARTICLE 10: AMENDMENTS:

All amendments or any changes to the provisions specified in this Contract can only occur when mutually agreed upon by the Town and Contractor. Further, such amendments or changes shall be in writing and signed by officials with authority to bind the Town. No amendment or change to the contract provisions shall be made until after the written execution of the amendment or change to the Contract by both parties.

ARTICLE 11: INDEPENDENT CONTRACTOR:

The Contractor acknowledges and agrees that it is acting as an independent contractor for all work and services rendered pursuant to this Agreement and shall not be considered an employee or agent of the Town for any purpose.

ARTICLE 12: INSURANCE:

The Contractor shall be responsible to the Town or any third party for any property damage or bodily injury caused by it, any of its subcontractors, employees or agents in the performance of, or as a result of, the work under this Agreement. The Contractor and any subcontractors used hereby certify that they are insured for workers' compensation, property damage, personal and product liability. The Contractor and any subcontractor it uses shall purchase, furnish copies of, and maintain in full force and effect insurance policies in the amounts here indicated.

- 1) General Liability of at least \$1,000,000 Occurrence/\$3,000,000 General Aggregate. The Municipality should be named as an "Additional Insured". Products and Completed Operations should be maintained for up to 3 years after the completion of the project.
- 2) Automobile Liability (applicable for any contractor who has an automobile operating exposure) of at least \$1,000,000 Bodily Injury and Property Damage per accident. The Municipality should be named as an "Additional Insured".
- 3) Workers' Compensation Insurance as required by law. Include Employers Liability Part B with a limit of \$1,000,000
- 4) Property Coverage for materials and services being transported by the contractor, as the Town's Property Contract provides coverage for personal property within 1000 feet of the premises.
- 5) Umbrella Liability of at least \$2,000,000/ occurrence, \$2,000,000/aggregate. The Municipality should be named as an "Additional Insured".

Prior to commencement of any work under this Agreement, the Contractor shall provide the Town with Certificates of Insurance which include the Town as an additional named insured and which include a thirty day notice of cancellation to the Town.

ARTICLE 13: SEVERABILITY:

If any term or condition of this Agreement or any application thereof shall to any extent be held invalid, illegal or unenforceable by the court of competent jurisdiction, the validity, legality, and enforceability of the remaining terms and conditions of this Agreement shall not be deemed affected thereby unless one or both parties would be substantially or materially prejudiced.

ARTICLE 14: ENTIRE AGREEMENT:

This Agreement, including all documents incorporated herein by reference, constitutes the entire integrated agreement between the parties with respect to the matters described. This Agreement supersedes all prior agreements, negotiations and representations, either written or oral, and it shall not be modified or amended except by a written document executed by the parties hereto.

ARTICLE 15: COUNTERPARTS:

This Agreement may be executed in any number of counterparts, each of which shall be deemed to be a counterpart original.

CERTIFICATION AS TO PAYMENT OF STATE TAXES

Pursuant to Chapter 62C of the Massachusetts General Laws, Section 49A(b), I, Oscar Farrell, authorized signatory for the Contractor do hereby certify under the pains and penalties of perjury that said Contractor has complied with all laws of the Commonwealth of Massachusetts relating to taxes, reporting of employees and contractors, and withholding and remitting child support.

04-249-5296
Social Security Number or
Federal Identification Number

Oscar Farrell
Signature of Individual or
Corporate Name

By:
Corporate Officer
(if applicable)

IN WITNESS WHEREOF, the parties hereto have caused this Agreement to be executed on the day and year first above written.

CONTRACTOR
By
Oscar Farrell
Treasurer
Printed Name and Title

TOWN OF HARWICH
by its Board of Selectmen Over \$50,000
[Signature]
[Signature]
John Ballantine

Approved as to Availability of Funds:

Finance Director (\$ _____)
Contract Sum

by its Town Administrator Up to \$50,000

Town Administrator

TOWN OF HARWICH

Invitation for Bids For

East Harwich Union Cemetery Gravestone Preservation Project

I. General Information and Bid Submission Requirements.

The Town of Harwich, acting by and through its Board of Selectmen, is soliciting sealed bids for **East Harwich Union Cemetery Gravestones Preservation Project**. The contract awarded pursuant to this Invitation for Bids, M.G.L. c. 30, § 39M, shall be for services provided through June 30, 2023; A specific scope of work is included as **Attachment A**.

Sealed bids shall be submitted to the Office of the Town Administrator, 732 Main Street, Town Hall, Harwich, MA, 02645 on or before **2:00 PM, Wednesday, August 3, 2022**, at which time all bids shall be opened publicly. If, at the time of the scheduled opening, the Town Hall is closed due to uncontrolled events such as fire, snow, ice, wind or unforeseen building closure, the bid opening will be postponed until 2:00 PM on the next business day on which the Town Hall is opened for business. Bids will be accepted until that date and time.

A bidder shall submit 1 (one) copy of its bid in a sealed envelope, clearly marked on its face with the bidder's name and address and the bid title: "**East Harwich Union Cemetery Gravestones Preservation Project**". Bids must be received in the appropriate office as indicated above prior to the submission deadline. The Town shall not be responsible for the inadvertent opening of any bid not appropriately identified as required prior to the submission deadline. The bidder shall be solely responsible for the timely delivery of its bid. Bids shall be submitted on the Bid Form attached to this Invitation for Bids (IFB) as **Attachment B**. The Bid Form must be signed as follows: 1) if the bidder is an individual, by him/her personally; 2) if the bidder is a partnership, by the name of the partnership, followed by the signature of each general partner; and 3) if the bidder is a corporation, by the authorized officer, whose signature must be attested to by the Clerk/Secretary of the corporation and the corporate sealed affixed to the Certificate of Vote included in this IFB.

The Town reserves the right to cancel this IFB, or to reject in whole or in part any and all bids, if it is determined to be in the best interests of the Town to do so. The Town further reserves the right to award one or more contracts under this IFB to the lowest bid by a responsive and responsible bidder in order to provide the most economical pricing structure.

A bidder may correct, modify, or withdraw a previously submitted bid by written notice received in the Town Administrator's office at the address indicated above prior to the time and date for the opening of bids. Bid modifications must be submitted in a sealed envelope clearly marked, with the bidder's name and address and the bid title "**East Harwich Union Cemetery Gravestones Preservation Project – Modification No. ___**".

After the bid opening, a bidder may not change any provision of the bid in a manner prejudicial to the interests of the Town or fair competition. Minor informalities will be waived or the bidder will be permitted to correct them. If a mistake and the intended bid are clearly evident on the face of the Bid Form, the mistake will be corrected to reflect the intended correct bid, and the bidder will be notified in writing; the bidder may not withdraw the bid. A bidder may withdraw its bid if a

mistake is clearly evident on the face of the Bid Form, but the intended correct bid is not similarly evident.

The contract will be awarded within thirty (30) days after the bid opening. The time for the award may be extended for up to forty-five (45) additional days by mutual agreement between the Town and the apparent lowest responsive and responsible bidder. All bid prices submitted in response to this IFB must remain firm for thirty (30) days following bid opening, and for any extension of the time for award of the contract as provided above.

Questions concerning the terms of this IFB, must be submitted by e-mail to: Robbin Kelley, Cemetery Administrator at rkelly@town.harwich.ma.us by 4:00 PM on Monday, July 25, 2022. Responses to any such questions will be issued as an Addendum to this IFB and will be emailed to all parties who have requested a copy of this IFB.

Each bid submission shall contain the Bid Form (**Attachment B**), a Certificate of Non-Collusion (**Attachment C**), a Tax Compliance Certificate (**Attachment D**) and a Certificate of Vote (corporate bidders only) (**Attachment E**).

The successful bidder must execute the contract within ten (10) days of the Town's delivery of the contract in substantially the form attached hereto as **Attachment F**. In the event the successful bidder fails to execute the contract in a timely manner, the Town reserves the right to rescind the award, and to make a new award to the next lowest bidder.

II. Location and Work to be Done

The Work consists of Cemetery gravestones preservation at Union Cemetery in East Harwich, and all work incidental thereto, in accordance with the Specifications described in Attachment A.

The Contractor shall furnish all labor, services, materials, equipment, plant, machinery, apparatus, appliances, tools, supplies, and all other things necessary to do all work required for the completion of each item of the Work and as herein specified.

The Work to be done and paid for under any item shall not be limited to the exact extent mentioned or described but shall include all incidental work necessary or customarily done for the completion of that item.

III. Ability and Experience of Bidder

No award will be made to any bidder who cannot satisfy the Owner that he has sufficient ability and experience in this class of work and sufficient capital and plant to enable him to prosecute and complete the work successfully within the time named. The Owner's decision or judgment on these matters will be final, conclusive, and binding.

The Owner may make such investigations as it deems necessary, and the bidder shall furnish to the Owner, under oath if so required, all such information and data for this purpose as the Owner may request.

IV. Obligation of Bidder

At the time of the opening of bids, each bidder will be presumed to have inspected the site and to have read and to be thoroughly familiar with the Contract Documents (including all addenda). The failure or omission of any bidder to examine any form, instrument, or document shall in no way relieve any bidder from any obligation in respect of his bid.

V. Time for Completion

The successful general bidder must agree to fully complete the project before June 30, 2023.

VI. Comparison of Bids

Bids will be compared on the basis of prices set forth in the bid forms. In the event that there is a discrepancy between the lump sum or unit prices written in words and figures, the prices written in words will govern.

VII. Award of Contract

The Contract will be awarded to "the lowest responsible and eligible bidder" pursuant to General Laws Chapter 30B, section 5 (g). Such a bidder shall possess the skill, ability and integrity necessary for the faithful performance of the work, shall be able to furnish labor that can work in harmony with all other elements of labor employed, or to be employed, in the work, and shall otherwise comply with all applicable provisions of law. Contract award shall be subject to availability of an appropriation for funding.

VIII. INSURANCE

The Contractor shall carry and continuously maintain until completion of the Contract, insurance as specified in Agreement and in such form as shall protect him performing work covered by this Contract, and the Town of Harwich and its employees, agents and officials, from all claims an liability for damages for bodily injury, including accidental death, and for property damage, which may arise from operations under this Contract. The Town shall be named as an additional insured. The Contractor covenants and agrees to hold the Town and its employees, agents and officials harmless from loss or damage due to claims for bodily injury or death and/or property damage arising from, or in connection with, operations under this Contract.

III. Rule for Award

The Town reserves the right to award the contract to the responsive and responsible bidder offering the lowest price for the supplies/services specified in the IFB and Attachment A. Such a bidder shall possess the skill, ability and integrity necessary for the faithful performance of the work, shall be able to furnish labor that can work in harmony with all other elements of labor employed, or to be employed, in the work, and shall otherwise comply with all applicable provisions of law. Contract award shall be subject to availability of an appropriation for funding.

ATTACHMENT A

(Purchase Description-see separate document)

ATTACHMENT B

FORM OF GENERAL BID

Bid of _____ (hereinafter called "Bidder")*
() a corporation, organized and existing under the laws of the state of _____

() a partnership

() a joint venture

() an individual

doing business as _____

To the Town of Harwich, Massachusetts (hereinafter called "Owner").

Gentlemen:

A) The undersigned Bidder, in compliance with your invitation for bids for the project known as East Harwich Union Cemetery Gravestone Preservation having examined the plans and specifications and related documents and the site of the proposed work, and being familiar with all of the conditions surrounding the proposed project including the availability of materials and labor, hereby proposes to furnish all labor, materials, and supplies, and to complete the project in accordance with the contract documents and the plans and specifications within the time set forth below, and at the prices stated below. These prices are to cover all expenses incurred in performing the work required under the contract documents, of which this bid is a part.

The Bidder hereby agrees to commence work on or before the date to be specified in written "Notice to Proceed" of the Owner, and to fully complete the project within _____ consecutive calendar days thereafter.

*Specify corporation, partnership or individual as applicable.

B) Bidder acknowledges receipt of and this bid includes the following addenda:

No. Dated:

No. Dated:

C) The Bidder agrees to perform the bid work described in the specifications and shown on the plans for the following contract price: \$ _____.

The above unit prices shall include all labor, materials, bailing, shoring, removal, overhead, profit, insurance, etc., to cover the finished work of the several kinds called for.

The Bidder understands that all bids for this project are subject to the applicable bidding laws of the Commonwealth of Massachusetts, including General Laws Chapter 30B

The Bidder understands that the Owner reserves the right to reject any or all bids and to waive any informalities in the bidding.

The Bidder agrees that this bid shall be good and may not be withdrawn for a period of 30 days, Saturdays, Sundays and legal holidays excluded, after the opening of bids.

Within 10 days of receipt of the written notice of acceptance of this bid, the Bidder will execute the formal Agreement set forth in Attachment F: Contract.

The undersigned offers the following information as evidence of his qualifications to perform the work as bid upon according to all the requirements of the plans and specifications.

1. Have been in business under present name for ____ years.
2. The names and addresses of all persons interested in the bid (if made by a partnership or corporation) as principals, are as follows:

(attach supplementary list if necessary)

3. The bidder is requested to state below what work of a similar character to that included in the proposed contract he has done, and give references that will enable the Owner to judge his experience, skill and business standing (add supplementary page if necessary).

Completion Date	Project Name	Contract Amount	Design Engineer	Reference Name	Telephone No.
-----------------	--------------	-----------------	-----------------	----------------	---------------

A: _____

B: _____

C: _____

D: _____

ATTACHMENT C

CERTIFICATE OF NON-COLLUSION

The undersigned certifies under penalties of perjury that this bid or proposal has been made and submitted in good faith and without collusion or fraud with any other person. As used in this certification, the word "person" shall mean any natural person, business, partnership, corporation, union, committee, club, or other organization, entity, or group of individuals.

(Signature of person signing the bid)

(Name of Business)

ATTACHMENT D

CERTIFICATE OF TAX COMPLIANCE

Pursuant to Chapter 62C of the Massachusetts General Laws, Section 49A(b), I,

_____, authorized signatory for

_____, do hereby certify under the pains and penalties
(Name of Contractor)

of perjury that said contractor has complied with all laws of the Commonwealth of
Massachusetts relating to taxes, reporting of employees and contractors, and withholding and
remitting child support.

CONTRACTOR

By: _____
(Signature of Authorized Representative)

Title: _____

Date: _____, 20__

ATTACHMENT E

CERTIFICATE OF CORPORATE AUTHORITY

At a duly authorized meeting of the Board of Directors of _____
(Name of Corporation)

held on _____ it was VOTED that:
(Date)

(Name)

(Officer)

of this corporation, be and he/she hereby is authorized to execute contracts, deeds and bonds in the name and on behalf of said corporation, and affix its corporate seal hereto; and such execution of any contract, deed or obligation in this corporation's name on its behalf by such

_____ under seal of the company, shall be valid and binding upon this
(Officer)

corporation.

A True Copy,

ATTEST: _____

TITLE: _____

PLACE OF BUSINESS: _____

DATE OF THIS CERTIFICATE: _____

I hereby certify that I am the clerk of the _____
that _____ is the duly elected _____ of said
corporation, and that the above vote has not been amended or rescinded and remains in full force
and effect as of the date of this contract.

(Clerk)

CORPORATE SEAL:

ATTACHMENT F

CONTRACT

AGREEMENT FOR PINE GROVE CEMETERY GRAVESTONE CONSERVATION

The following provisions shall constitute an Agreement between the Town of Harwich, acting by and through its Board of Selectmen, hereinafter referred to as "Town," and

_____, with an address of

_____, hereinafter referred to as "Contractor", effective as of the ____ day of _____, 2022. In consideration of the mutual covenants contained herein, the parties agree as follows:

ARTICLE 1: SCOPE OF WORK:

The Contractor shall perform all work and furnish all services necessary to provide the Town with East Harwich Union Cemetery Gravestone Preservation, as set forth in Attachment A.

ARTICLE 2: TIME OF PERFORMANCE:

The Contractor shall complete all work and services required hereunder commencing upon execution of this contract, through June 30, 2023.

ARTICLE 3: COMPENSATION:

The Town shall pay the Contractor for the performance of the work outlined in Article 1 above the contract sum of \$_____. The Contractor shall submit monthly invoices to the Town for services rendered, which will be due 30 days following receipt by the Town.

ARTICLE 4: CONTRACT DOCUMENTS:

The following documents form the Contract and all are as fully a part of the Contract as if attached to this Agreement or repeated herein:

1. This Agreement.
2. Amendments, or other changes mutually agreed upon between the parties.
3. All attachments to the Agreement.

In the event of conflicting provisions, those provisions most favorable to the Town shall govern.

ARTICLE 5: CONTRACT TERMINATION:

The Town may suspend or terminate this Agreement by providing the Contractor with ten (10) days written notice for the reasons outlined as follows:

1. Failure of the Contractor, for any reason, to fulfill in a timely and proper manner its obligations under this Agreement.
2. Violation of any of the provisions of this Agreement by the Contractor.
3. A determination by the Town that the Contractor has engaged in fraud, waste, mismanagement, misuse of funds, or criminal activity with any funds provided by this Agreement.

Either party may terminate this Agreement at any time for convenience by providing the other party written notice specifying therein the termination date which shall be no sooner than thirty (30) days from the issuance of said notice. Upon receipt of a notice of termination from the Town, the Contractor shall cease to incur additional expenses in connection with the Agreement. Upon such termination, the Contractor shall be entitled to compensation for all satisfactory work completed prior to the termination date as determined by the Town. Such payment shall not exceed the fair value of the services provided hereunder.

ARTICLE 6: INDEMNIFICATION:

The Contractor shall defend, indemnify and hold harmless the Town and its officers, agents, and all employees from and against claims arising directly or indirectly from the contract. Contractor shall be solely responsible for all local taxes or contributions imposed or required under the Social Security, Workers' Compensation, and income tax laws. Further, the Contractor shall defend, indemnify and hold harmless the Town with respect to any damages, expenses, or claims arising from or in connection with any of the work performed or to be performed under this Agreement. This shall not be construed as a limitation of the Contractor's liability under the Agreement or as otherwise provided by law.

ARTICLE 7: AVAILABILITY OF FUNDS:

The compensation provided by this Agreement is subject to the availability and appropriation of funds.

ARTICLE 8: APPLICABLE LAW:

The Contractor agrees to comply with all applicable local, state and federal laws, regulations and orders relating to the completion of this Agreement. This Agreement shall be governed by and construed in accordance with the law of the Commonwealth of Massachusetts.

ARTICLE 9: ASSIGNMENT:

The Contractor shall not make any assignment of this Agreement without the prior written approval of the Town.

ARTICLE 10: AMENDMENTS:

All amendments or any changes to the provisions specified in this Contract can only occur when mutually agreed upon by the Town and Contractor. Further, such amendments or changes shall be in writing and signed by officials with authority to bind the Town. No amendment or change to the contract provisions shall be made until after the written execution of the amendment or change to the Contract by both parties.

ARTICLE 11: INDEPENDENT CONTRACTOR:

The Contractor acknowledges and agrees that it is acting as an independent contractor for all work and services rendered pursuant to this Agreement and shall not be considered an employee or agent of the Town for any purpose.

ARTICLE 12: INSURANCE:

The Contractor shall be responsible to the Town or any third party for any property damage or bodily injury caused by it, any of its subcontractors, employees or agents in the performance of, or as a result of, the work under this Agreement. The Contractor and any subcontractors used hereby certify that they are insured for workers' compensation, property damage, personal and product liability. The Contractor and any subcontractor it uses shall purchase, furnish copies of, and maintain in full force and effect insurance policies in the amounts here indicated.

- 1) General Liability of at least \$1,000,000 Occurrence/\$3,000,000 General Aggregate. The Municipality should be named as an "Additional Insured". Products and Completed Operations should be maintained for up to 3 years after the completion of the project.
- 2) Automobile Liability (applicable for any contractor who has an automobile operating exposure) of at least \$1,000,000 Bodily Injury and Property Damage per accident. The Municipality should be named as an "Additional Insured".
- 3) Workers' Compensation Insurance as required by law. Include Employers Liability Part B with a limit of \$1,000,000
- 4) Property Coverage for materials and services being transported by the contractor, as the Town's Property Contract provides coverage for personal property within 1000 feet of the premises.
- 5) Umbrella Liability of at least \$2,000,000/ occurrence, \$2,000,000/aggregate. The Municipality should be named as an "Additional Insured".

Prior to commencement of any work under this Agreement, the Contractor shall provide the Town with Certificates of Insurance which include the Town as an additional named insured and which include a thirty day notice of cancellation to the Town.

ARTICLE 13: SEVERABILITY:

If any term or condition of this Agreement or any application thereof shall to any extent be held invalid, illegal or unenforceable by the court of competent jurisdiction, the validity, legality, and enforceability of the remaining terms and conditions of this Agreement shall not be deemed affected thereby unless one or both parties would be substantially or materially prejudiced.

ARTICLE 14: ENTIRE AGREEMENT:

This Agreement, including all documents incorporated herein by reference, constitutes the entire integrated agreement between the parties with respect to the matters described. This Agreement supersedes all prior agreements, negotiations and representations, either written or oral, and it shall not be modified or amended except by a written document executed by the parties hereto.

ARTICLE 15: COUNTERPARTS:

This Agreement may be executed in any number of counterparts, each of which shall be deemed to be a counterpart original.

CERTIFICATION AS TO PAYMENT OF STATE TAXES

Pursuant to Chapter 62C of the Massachusetts General Laws, Section 49A(b), I,

_____, authorized signatory for the Contractor do hereby certify under the pains and penalties of perjury that said Contractor has complied with all laws of the Commonwealth of Massachusetts relating to taxes, reporting of employees and contractors, and withholding and remitting child support.

Social Security Number or
Federal Identification Number

Signature of Individual or
Corporate Name

By:
Corporate Officer
(if applicable)

IN WITNESS WHEREOF, the parties hereto have caused this Agreement to be executed on the day and year first above written.

CONTRACTOR

TOWN OF HARWICH

By

by its Board of Selectmen (over \$50,000)

Printed Name and Title

Approved as to Availability of Funds:

by its Town Administrator Up to \$50,000

Town Accountant (\$ _____)
Contract Sum

Town Administrator

1994 ANNUAL REPORT

OF THE

OFFICERS OF THE TOWN OF

HARWICH

FOR THE YEAR ENDING DECEMBER 31, 1994

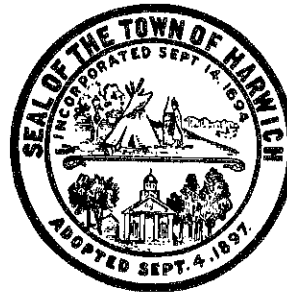

Typesetting · Printing · Binding

by

J & R Graphics, Inc.

155-L Webster Street · Hanover, MA 02339 · (800) 852-2252

Action on Main Motion as Amended: A 2/3 majority vote is needed. It is a unanimous vote, and I so declare it.

Article 81. Cemetery - No Dogs in Cemetery Bylaw.

Article 81. To see if the Town will vote to amend Article 4, Public Safety, Part 8, of the General By-Laws by adding thereto a new section to read as follows: "No person shall come upon any Town-owned or Town-maintained cemetery with a dog or allow their dog to run loose onto such property. A violation of this section shall be punishable by a fine of fifty (\$50.00) dollars."

Said section to be numbered 4-813 and the present section 4-813 shall be numbered 4-814 and to act fully thereon. By request of the Cemetery Commission.

Motion: (Nancy Kuhn, Chairman - Finance Committee) I move that this article be accepted and adopted. (duly seconded)

Action: (Michael D. Ford, Moderator) It is a vote.

Article 82. Highways - State Aid I.

Article 82. To see if the Town will vote to raise and appropriate in anticipation of reimbursement, the sum of \$258,722.00 as the State's share of the cost of work under Chapter 90, Section 34 (2A), of the General Laws, being funded by Chapter 15 and to act fully thereon. By request of the Director of Highways and Maintenance.

Motion: (Nancy Kuhn, Chairman - Finance Committee) I move that this article be accepted and adopted and that the sum of \$258,722.00 be raised and appropriated for this purpose, and that the Treasurer, with the approval of the Selectmen, be authorized to issue bonds or notes pursuant to the provisions of General Laws Chapter 44, provided however, that this vote shall not take effect until the town, at a regular or special election, votes to exempt from the limitations on total taxes imposed by the General Laws Chapter 59, Section 21C, amounts required to pay for the principal of and interest on the borrowing authorized by this vote. (duly seconded)

Action: (Michael D. Ford, Moderator) A 2/3 majority vote is needed. It is a unanimous vote, and I so declare it.

Article 83. Highways - State Aid II.

Article 83. To see if the Town will vote to raise and appropriate in anticipation of reimbursement, the sum of \$258,722.00 as the State's share of the cost of work under Chapter 90, Section 34 (2A), of the General Laws, being funded by Chapter 15A and to act fully thereon. By request of the Director of Highways and Maintenance.

Warren Nichols Landscape & Design

Warren Nichols
30 Moss Hill Rd
Harwich, MA 02645

Estimate

Date	Estimate #
7/5/2022	32

Name / Address
Harwich Cemetery Commision

Project

Description	Qty	Rate	Total
Insect control for Evergreen Cemetery new section. Approximately 5 Acres	5	240.00	1,200.00
Total			\$1,200.00

CONSERVATION OF MONUMENTS AND
GRAVESTONES AT PINE GROVE CEMETERY,
WEST HARWICH MA

Report prepared by Michael Gallagher
Village Green Restoration Inc
34 Currier Rd
East Falmouth, MA
617-721-1529
mike@villagegreenrestoration.com

PROJECT DESCRIPTION

- In the spring of 2022, Village Green Restoration Inc conserved both gravestones and multi-unit monuments in Pine Grove Cemetery, West Harwich MA. Conservation was carried out by Michael Gallagher and Ethan Howard of Village Green Restoration Inc.





METHODOLOGY GRAVESTONES

Conservation methods adhered to specifications as provided by Ivan Meijer of Building Conservation Inc. A brief description follows.





- Gravestones were identified and documented.
- Downed and leaning gravestones were carefully excavated and hoisted.
- Broken monuments were repaired using Bonstone Clear Knife Grade Epoxy. Stainless steel pins were inserted when necessary and feasible.
- Cracks and areas of loss were repaired with the following:
 - Slate – large patches and cracks Edison Coatings Custom System 45. Small cracks and areas of delamination Acryloid B-72, acetone and stone dust
 - Marble – Lithomix Natural Hydraulic Cement for Stone Repair “Aged Marble” color.
- Slab Gravestones were reset in ¾” dense grade bluestone compacted every six inches.
- If a gravestone did not have a sufficient length to set in the ground, a new custom concrete slot base was cast. The slab was set in the new base using a Type N mortar.
- Multi-unit gravestones were disassembled and then re-set using stainless steel threaded pins set with Bonstone Epoxy on one side and a type n mortar on the opposite side.
- Slot base and multi-unit gravestones were set on new poured concrete foundations of a depth of 3’. Bases were set to new foundations using Type S mortar.



METHODOLOGY MONUMENTS



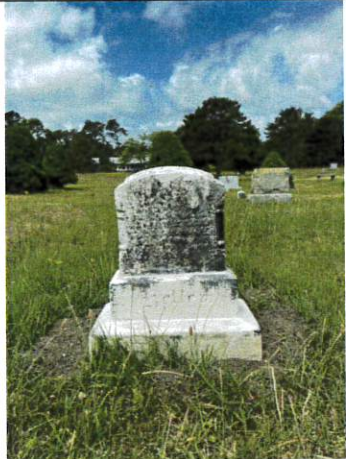

- Multi part monuments were carefully disassembled and laid on blocking.
- Rubble foundations were removed and new reinforced concrete foundations were poured.
- New pin holes were drilled in each unit.
- Monuments were reassembled with stainless threaded pins between units. One side of the pin was set in Bonstone Epoxy while the opposite was set with Type N thin set mortar.
- Joints between units were set with type N thin set mortar and plastic shims.
- Areas of loss and cracks were repaired with Lithomix Natural Hydraulic Lime Stone Repair Mortar.

Name, Road, Lot, Repair	Photo Before	Photo Aerft
<p>Harold Wilson, Pine Ave 3&4</p> <p>Re-set 3 footstones</p>		
<p>Frederick Chase Pine Avenue 11</p> <p>Reset Kenneth Stone</p> <p>Re-set on new foundation, re-pinned</p>		

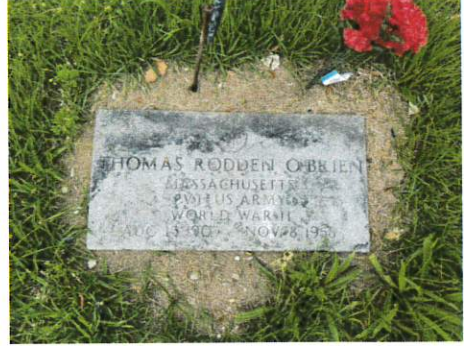

Name, Lot, Repair	Photo Before	Photo After
<p>Emma Baker 22 Pine Avenue</p> <p>William Baker Stone Straigtened, reset on new foundation repinned</p>		
<p>Charles Hall 27 Pine Avenue</p> <p>Raise 5 foot markers</p>	 	





Name, Lot, Repair	Photo Before	Photo After
<p>George Kelley 28 Pine Avenue Reset and align two foot markers</p>		
<p>JD Chase 33 Pine Avenue Resett and repair White Memorial Reset JOB Memorial</p>	 	

Name, Lot, Road, Repair	Photo Before	Photo After
<p data-bbox="230 233 422 346">Cyrus B Kelley 39 Oak Avenue</p> <p data-bbox="230 388 446 462">Nellie reset and repinned</p>		
<p data-bbox="230 968 397 1081">J.B. O'Brien 40 Oak Avenue</p> <p data-bbox="230 1123 446 1228">Thomas O'Brien Military marker reset.</p>		



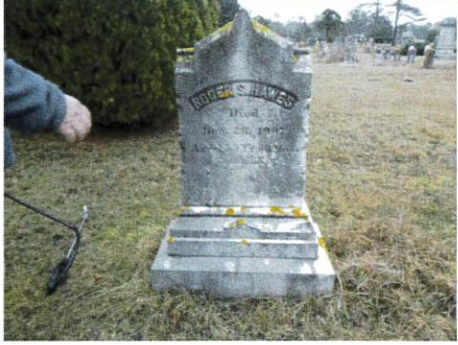

Name, Lot, Road, Repair	Photo Before	Photo After
<p data-bbox="241 243 440 348">Robert Lothrop 41 Oak Avenue</p> <p data-bbox="241 394 477 499">Mary and Gershom footmarkers reset.</p>		
<p data-bbox="241 978 423 1041">Charles Chase 43</p> <p data-bbox="241 1087 461 1234">Corner markers and 4 footstones reset and realigned.</p>		



Name, Lot, Road, Repair	Photo Before	Photo After
<p data-bbox="245 243 435 348">James B Doane 44 Oak Avenue</p> <p data-bbox="245 394 428 457">Corner marker reset</p>		
<p data-bbox="245 978 412 1083">Antone Silver 45 Oak Avenue</p> <p data-bbox="245 1129 412 1192">Octavia Silver reset</p>		



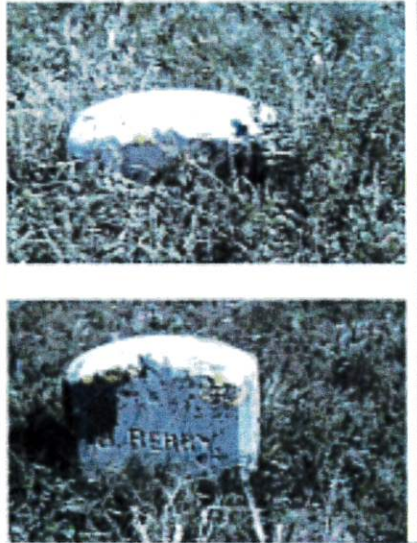

Name, Lot, Road, Repair	Photo Before	Photo After
<p>Clara M Long 51 Oak Avenue</p> <p>Father reset and aligned.</p>		
<p>John T Wood 56 Oak Avenue</p> <p>Reset two foot stones.</p>		

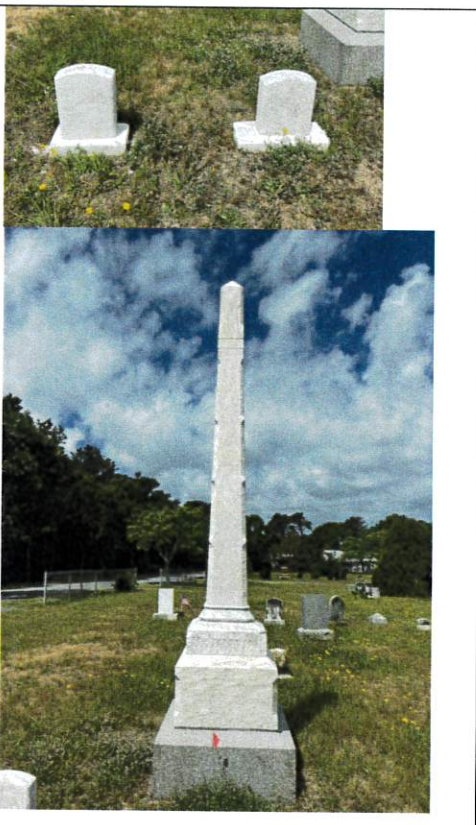

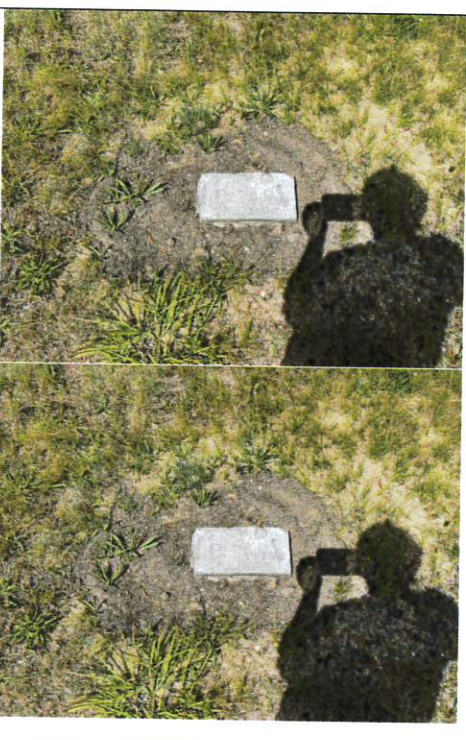

Name, Lot, Road, Repair	Photo Before	Photo After
<p>RS Howes 57 Oak Avenue</p> <p>Gravestone leveled and reset.</p>		
<p>JB Doane 59 Oak Avenue</p> <p>Aligned Father and Mother</p> <p>Reset Father.</p> <p>Cleaned and conserved Obelisk</p>		



Name, Lot, Road, Repair	Photo Before	Photo After
<p>Alex Baker 60 Oak Avenue</p> <p>Clean and Conserve</p>		
<p>Henry T Nickerson 61 Oak Avenue</p> <p>Father stone reset and aligned</p>		



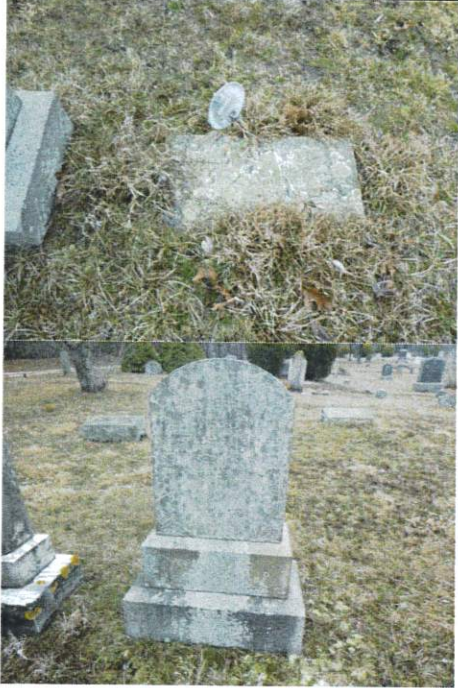
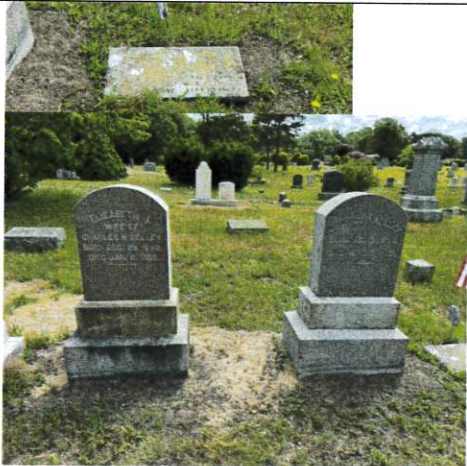

Name, Lot, Road, Repair	Photo Before	Photo After
<p>Baxter Kelley 62 Oak Avenue</p> <p>Reset and align Emma, Eliza and Baxter footstones.</p>		
<p>J Berry Jr 64 Oak Avenue</p> <p>Reset two footstones</p>		

Name, Lot, Road, Repair	Photo Before	Photo After
<p>James Barnaby 66 Cedar Avenue</p> <p>Clean and Consolidate Large and small memorial Repairs on 2 foundations Father and Mother and unable to read</p>		
<p>Kelley B Chase 69 Cedar Avenue</p> <p>Reset father and mother.</p>		

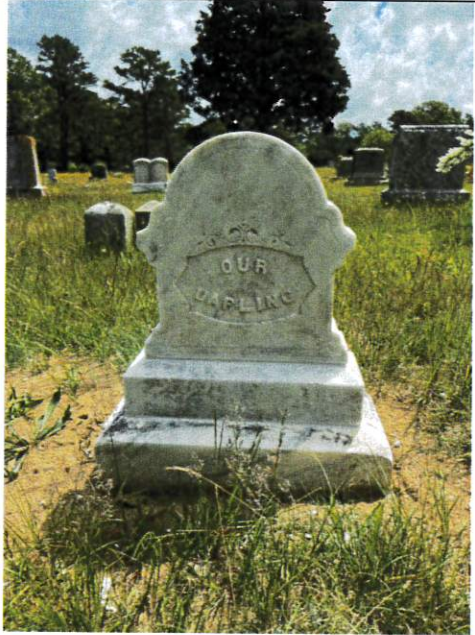

Name, Lot, Road, Repair	Photo Before	Photo After
<p>Peter Raymond 71 Cedar Avenue</p> <p>Reset two footstones</p>		
<p>RE Howes 73 Cedar Avenue</p> <p>Resett and repair Elinor, Mary and Russel stones.</p>	 	 





Name, Lot, Road, Repair	Photo Before	Photo After
<p>Samuel James 75 Cedar Avenue</p> <p>Reset and repined Theresa stone</p>		
<p>Virginia Chase Next to Zaddock Chase</p> <p>Cedar Avenue</p> <p>Reset corner marker</p>		



Name, Lot, Road, Repair	Photo Before	Photo After
<p>Charles Kelley 84 Cedar Avenue</p> <p>Elizabeth and Charles reset and repined. Military marker reset.</p>		
<p>George F Kelley 88 Cedar Avenue</p> <p>Our Darling reset and repined.</p>		



Name, Lot, Road, Repair	Photo Before	Photo After
<p>Jonathan Kelley 2nd 90 Cedar Avenue</p> <p>Alemena K and stairs reset.</p>		
<p>Isaiah Ellis 92 Cedar Avenue</p> <p>Double stone Mother & Father reset and repined.</p> <p>Judah and additional stone broken in two pieces repaired and reset.</p>		



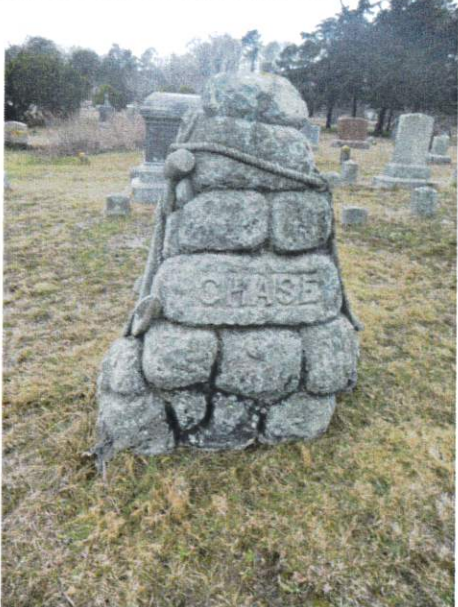
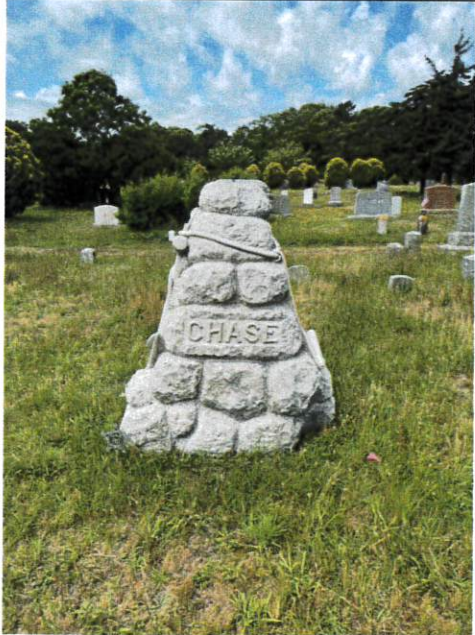

Name, Lot, Road, Repair	Photo Before	Photo After
<p>Everett Harris 96 Cedar Avenue</p> <p>5 footstones reset.</p>		
<p>JA Harris 97 Cedar Avenue</p> <p>Monument cleaned and consolidated.</p>		

Name, Lot, Road, Repair	Photo Before	Photo After
<p data-bbox="256 268 446 373">Neri Chase 99 Willow Avenue</p> <p data-bbox="256 415 462 451">Reset memorial.</p>		
<p data-bbox="243 1003 397 1108">Thomas Ellis 103 Willow Ave</p> <p data-bbox="243 1150 397 1255">Monument cleaned and conserved.</p>		

Name, Lot, Road, Repair	Photo Before	Photo After
<p data-bbox="248 285 462 384">Nehemiah Kelley 104 Willow Ave</p> <p data-bbox="248 432 462 531">Vickie memorial repaired, repined and reset.</p> <p data-bbox="248 579 462 646">Obelisk cleaned and consolidated.</p>		
<p data-bbox="248 1010 389 1119">G Kelley 105 Willow Ave</p> <p data-bbox="248 1167 462 1266">Gravestone and stairs, repaired, repined and reset.</p>		





Name, Lot, Road, Repair	Photo Before	Photo After
<p>WW Chase 107 Willow Ave</p> <p>Resett corner markers.</p>		
<p>Whitman Chase 109 Willow Ave</p> <p>Cleaned and consolidated.</p>		



Name, Lot, Road, Repair	Photo Before	Photo After
<p>Charles Kelley 111 Willow Save</p> <p>Repaired, repined and reset.</p>		
<p>John Keppel 114 Willow Ave</p> <p>Reset Father stone.</p>		

Name, Lot, Road, Repair	Photo Before	Photo After
<p>NW Garland 115 Willow Ave</p> <p>Reset corner marker</p>		
<p>Eleanor P Chase 117 Willow Ave</p> <p>Eleanor and Obed stone reset.</p>		

Name, Lot, Road, Repair	Photo Before	Photo After
<p data-bbox="248 285 397 390">Abbie Small 118 Willow Ave</p> <p data-bbox="248 432 448 499">Abbie memorial reset.</p>		
<p data-bbox="248 1014 391 1119">Chase 120 Willow Ave</p> <p data-bbox="248 1161 412 1228">Lavinia stone reset.</p>		





Name, Lot, Road, Repair	Photo Before	Photo After
<p data-bbox="245 281 415 386">Joshua Chase 121 Willow Ave</p> <p data-bbox="245 428 415 495">Cleaned and consolidated.</p>		
<p data-bbox="245 1010 415 1115">Erastus Chase 124 Willow Ave</p> <p data-bbox="245 1157 461 1224">Obelisk reset and pinned.</p> <p data-bbox="245 1266 461 1333">Sarah Abby Chase reset.</p>		

Name, Lot, Road, Repair	Photo Before	Photo After
<p>David Kelley 127 Willow Ave</p> <p>Babies repaired and reset.</p> <p>Abby, Emma and Mother reset.</p>		
<p>Warren Smith 129 Linden</p> <p>Hellen Ellis and Emily Smith reset.</p>		

Name, Lot, Road, Repair	Photo Before	Photo After
<p>Jossen Poole 136 Linden Ave</p> <p>Joseph and Anaretta reset.</p>		
<p>Amos Wixon 140 Linden Ave</p> <p>Raised and reset 3 foot stones.</p>		





Name, Lot, Road, Repair	Photo Before	Photo After
<p>Nathan Chase 145 Linden Ave</p> <p>Reset memorial</p>		
<p>Martin Chase 147 Linden Ave</p> <p>Jennie Cole Memorial repined and resett</p>		

Name, Lot, Road, Repair	Photo Before	Photo After
<p data-bbox="245 283 443 388">Benjamin Sears 150 Linden Ave</p> <p data-bbox="245 430 430 499">Tree removed, stone reset.</p>		
<p data-bbox="245 1018 414 1123">Thomas Crew 152 Linden Ave</p> <p data-bbox="245 1207 467 1459">Thomas & Bathsheba stones reset. Corner stone reset. Cobb/Crew memorial cleaned and conserved.</p>	 	 

Name, Lot, Road, Repair	Photo Before	Photo After
<p>Nehemiah Smith 153 Linden Ave</p> <p>Nehemiah Smith , Sarah and Jerusha stone reset.</p>		
<p>FG Doane 154 Linden Doane</p> <p>Wife and husband stones realigned.</p>		

Name, Lot, Road, Repair	Photo Before	Photo After
<p data-bbox="245 285 477 390">Nathaniel Robbins 155 Linden Ave</p> <p data-bbox="245 436 482 541">Cross repaired and pinned cleaned and conserved.</p>		
<p data-bbox="245 1016 436 1121">Anthony Kelley 156 Linden Ave</p>		





Name, Lot, Road, Repair	Photo Before	Photo After
<p data-bbox="253 275 454 380">Benjamin Chase 157 Linden Rd</p> <p data-bbox="253 422 480 527">\$ Headstones and Lamb cleaned and conserved.</p>		
<p data-bbox="245 1010 415 1115">Joseph Baker 161 Elm Ave</p> <p data-bbox="245 1157 480 1262">Caroline and Emiline footstones reset.</p>		

Name, Lot, Road, Repair	Photo Before	Photo After
<p>Peter Chase 163 Elm Ave</p> <p>Peter Chase reset.</p>		
<p>Hook lots & Martin Chase Lot 166, 169, 178 Elm Ave</p> <p>Reset two corner markers</p>		

Name, Lot, Road, Repair	Photo Before	Photo After
<p>J Walker 179 Elm Ave</p> <p>Removed tree, reset monument.</p>		
<p>Charles Hamilton 180 Elm Avenue</p> <p>Charles Hamilton reset.</p>		

Name, Lot, Road, Repair	Photo Before	Photo After
<p>Captain Alonzo Chase 184 Elm Avenue</p> <p>2 footstones reset.</p>		
<p>Ebenezer Smith 185 Elm Ave</p> <p>Memorial reset.</p>		

Name, Lot, Road, Repair	Photo Before	Photo After
<p>Gustavus Crowell 191 Maple Ave</p> <p>Tablet resett</p>		
<p>Celia B Bennett 194 Maple Ave</p> <p>Cora and Charles reset.</p>		

Name, Lot, Road, Repair	Photo Before	Photo After
<p data-bbox="250 285 383 390">Mcmillan 202A Maple Ave</p> <p data-bbox="250 432 431 495">Corner marker reset</p>		
<p data-bbox="250 1016 423 1121">Mercy Crowell 204 Maple Ave</p> <p data-bbox="250 1163 415 1226">Mother stone reset.</p>		

Name, Lot, Road, Repair	Photo Before	Photo After
<p>Susan K Howland 209 Maple Ave</p> <p>Reset Marion Howland.</p>		
<p>JR Sisson 211 Maople Ave</p> <p>Our Darling repaired and reset.</p>		

Name, Lot, Road, Repair	Photo Before	Photo After
<p>Jeremiah G Parks 215 & 216 Maple Ave</p> <p>JHT and APT reset and aligned.</p> <p>Memorial plaque reset and raised.</p>		
<p>Annie M Chase 243</p> <p>Birch Ave</p> <p>Memorial reset.</p>		

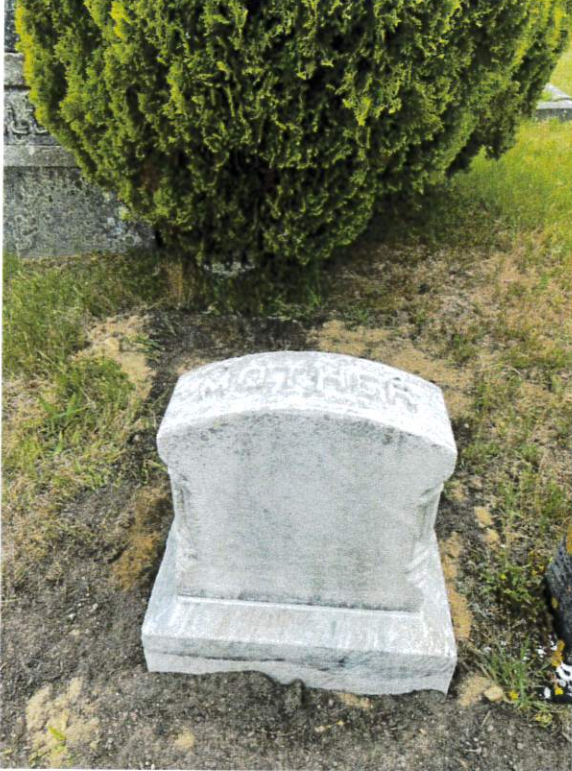
Additional Monuments Treated	Photo After
<p data-bbox="251 317 477 348">Debrah Nickerson</p> <p data-bbox="251 428 418 495">Repaired and reset.</p>	
<p data-bbox="251 1052 477 1119">Mother Repined and reset.</p>	

Additional monuments treated.

Photo After

Baker infants reset.



Baker reset.



Village Green Restoration
 34 Currier Rd
 East Falmouth, MA
 02536



Invoice

Bill To
Robin Kelly 742 Main St. Harwich, MA 02645

Project
Pine Grove

Date	Invoice No.	Terms
06/27/22	PG1	

Item	Description	Quantity	Rate	Amount
Headstone Conservation	Restoration/Conservation of 143 monuments at Pine Grove Cemetery per contract		42,000.00	42,000.00
Headstone Conservation	Repair/Restoration of Deborah Nickerson monument		900.00	900.00
Headstone Conservation	Resetting of 3 additional minuments (no charge)		0.00	0.00

PO # 22004

VENDOR #	26452	
INV #	PG1	
ORG	OBJECT	AMOUNT
80271292	620032	\$ 42,000
APPROVED BY	<i>Robin Kelly</i>	
	DEPARTMENT HEAD	
WARRANT NO.	WARRANT DATE	

Thank You!

VENDOR #	26452	
INV #	PG1	
ORG	OBJECT	AMOUNT
1611002	338000	\$ 900.-
APPROVED BY	<i>Robin Kelly</i>	
	DEPARTMENT HEAD	
WARRANT NO.	WARRANT DATE	

Subtotal	\$42,900.00
Sales Tax	\$0.00
Total	\$42,900.00



P 1
| gaacting

TOWN OF HARWICH - LIVE DATA
G/L ACCOUNT DETAIL

07/29/2022 13:56
wtulloch

Org: 80271292 Object: 620032
PINE GROVE GRAVESTONE 8027-0-000-0000-000-0-2-620032-

YEAR PER JOURNAL	EFF DATE	SRC T	PO/REF2	REFERENCE	AMOUNT	P	CHECK NO	WARRANT	VDR NAME/ITEM	DESC	COMMENTS
2022 01	190 07/21/2021	POE 4	22004	PO ENT/PRF	42,000.00	Y		0	VILLAGE GREEN	RES	Pine Grov

Total Amount: 42,000.00

** END OF REPORT - Generated by Wendy Tulloch **

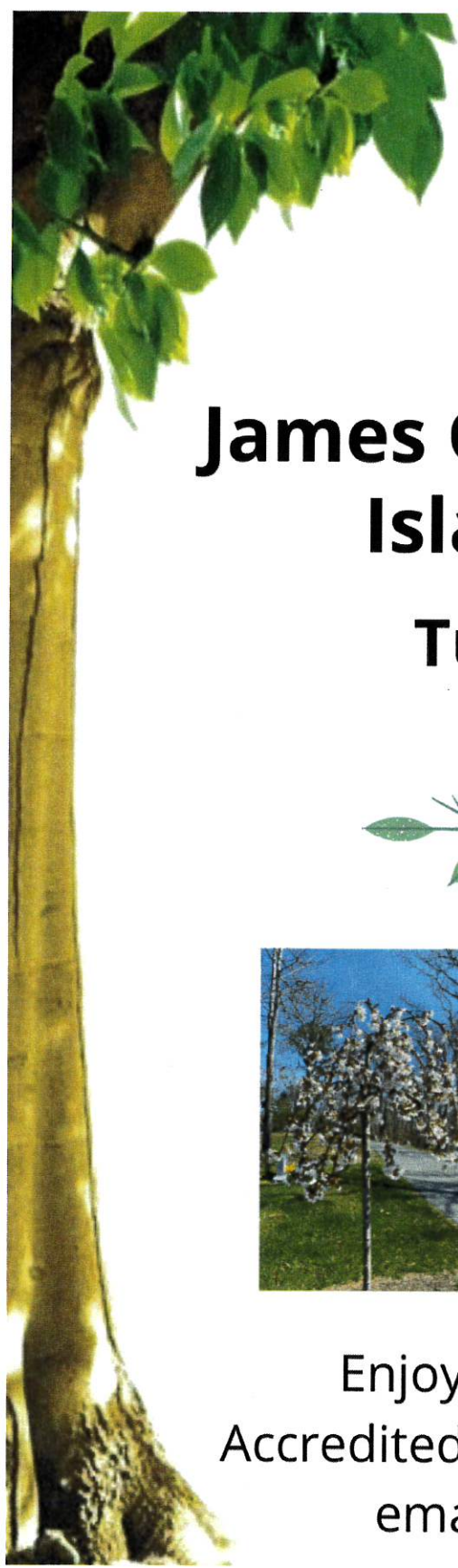

4th Annual



Tree Tour

James G. Marceline Arboretum Island Pond Cemetery

Tuesday, July 19th 2022
9:30am to 10:30am

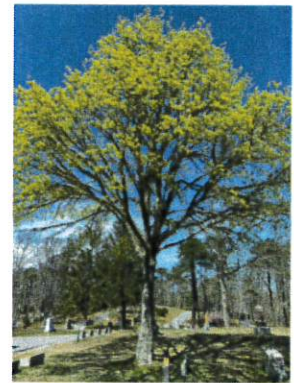

Enjoy a free, guided tour of the Level 1 Accredited Arboretum! To reserve a spot, please email rkelly@town.harwich.ma.us

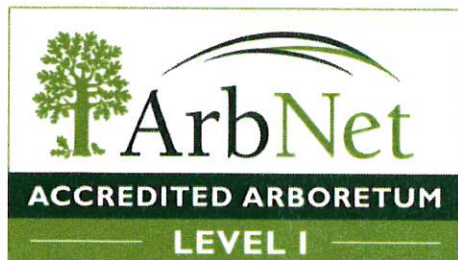

Robbin Kelley

From: Robin Lofgren <rblofgren@gmail.com>
Sent: Tuesday, July 19, 2022 3:01 PM
To: Madeline Oerth
Cc: Gerie Schumann; dcoombes58@hotmail.com; sandyconcannon@gmail.com; lwu429@gmail.com; barbars.harrison128@gmail.com; ejsully@comcast.net; sknowles45@gmail.com; lynnedrummond@comcast.net; pdwatson2@gmail.com; skaysmith@comcast.net; teresakatuska@gmail.com; amy9nat@aol.com; diverioa@yahoo.com; capepowers@comcast.net; pmcrocker@yahoo.com; notjustcapecodart@me.com; Robbin Kelley; Jodi Monroe
Subject: Re: 07/19 Tree Tour Followup

Hi Maddy!

I truly enjoyed the very informative tour this morning! You ladies sure work hard and I commend all of your efforts to make Island Pond a spectacular place to visit. I am sure some of the Garden Club of Harwich members would volunteer some time weeding and watering. Perhaps when it cools down in the fall?

Thank you all for sharing your knowledge with us. It was very enjoyable!

All the best to you two in your future endeavors.

Robin Lofgren

Sent from my iPhone

On Jul 19, 2022, at 2:39 PM, Madeline Oerth <madeline.oerth@barnstablecounty.org> wrote:

Hi Everyone!

Thank you so much for joining us on our tree tour in the James G. Marceline Arboretum at Island Pond Cemetery! I hope you all enjoyed your visit with us and learned a lot! If anyone is interested in volunteering with us in the future, please don't hesitate to reach out to Robbin at rkelley@town.harwich.ma.us. As you may have seen today, the arboretum requires a lot of maintenance (weeding, watering, etc.), so any help would be greatly appreciated! We hope to see you all again sometime soon!

It has truly been a pleasure serving the town of Harwich this year! Thank you!

Best,
Maddy

Robbin Kelley

From: Amy Natiello <amy9nat@aol.com>
Sent: Wednesday, July 20, 2022 6:40 AM
To: Madeline Oerth; Gerie Schumann; dcoombes58@hotmail.com; sandyconcannon@gmail.com; lwu429@gmail.com; barbar.harrison128@gmail.com; ejsully@comcast.net; sknowles45@gmail.com; lynn Drummond@comcast.net; pdwatson2@gmail.com; skysmith@comcast.net; teresakatuska@gmail.com; rblofgren@gmail.com; diverioa@yahoo.com; capepowers@comcast.net; pmcrocker@yahoo.com; notjustcapecodart@me.com
Cc: Robbin Kelley; Jodi Monroe
Subject: Re: 07/19 Tree Tour Followup

Hi Maddy,

The tour was wonderful. Thank you and Jodie for sharing your knowledge and for all your hard work both in the cemetery and on the Conservation Trust lands.

Wishing you a wonderful rest of the summer.
Best wishes to the both of you.
Amy Natiello

[Sent from the all new AOL app for iOS](#)

On Tuesday, July 19, 2022, 2:39 PM, Madeline Oerth <madeline.oerth@barnstablecounty.org> wrote:

Hi Everyone!

Thank you so much for joining us on our tree tour in the James G. Marceline Arboretum at Island Pond Cemetery! I hope you all enjoyed your visit with us and learned a lot! If anyone is interested in volunteering with us in the future, please don't hesitate to reach out to Robbin at rkelley@town.harwich.ma.us. As you may have seen today, the arboretum requires a lot of maintenance (weeding, watering, etc.), so any help would be greatly appreciated! We hope to see you all again sometime soon!

It has truly been a pleasure serving the town of Harwich this year! Thank you!

Best,
Maddy

Robbin Kelley

From: Eileen Sullivan <ejsully@comcast.net>
Sent: Wednesday, July 20, 2022 8:05 AM
To: Madeline Oerth
Cc: Gerie Schumann; dcoombes58@hotmail.com; sandyconcanon@gmail.com; lwu429@gmail.com; barbars.harrison128@gmail.com; sknowles45@gmail.com; lynnedrummond@comcast.net; pdwatson2@gmail.com; skaysmith@comcast.net; teresakatuska@gmail.com; amy9nat@aol.com; rblofgren@gmail.com; diverioa@yahoo.com; capepowers@comcast.net; pmcrocker@yahoo.com; notjustcapecodart@me.com; Robbin Kelley; Jodi Monroe
Subject: Re: 07/19 Tree Tour Followup

Thank you for a wonderful tour.
Eileen

Sent from my iPhone

On Jul 19, 2022, at 2:39 PM, Madeline Oerth <madeline.oerth@barnstablecounty.org> wrote:

Hi Everyone!

Thank you so much for joining us on our tree tour in the James G. Marceline Arboretum at Island Pond Cemetery! I hope you all enjoyed your visit with us and learned a lot! If anyone is interested in volunteering with us in the future, please don't hesitate to reach out to Robbin at rkelley@town.harwich.ma.us. As you may have seen today, the arboretum requires a lot of maintenance (weeding, watering, etc.), so any help would be greatly appreciated! We hope to see you all again sometime soon!

It has truly been a pleasure serving the town of Harwich this year! Thank you!

Best,
Maddy

<Outlook-cpqnibw1.png>

Madeline Oerth

Pronouns: she/her

AmeriCorps Member | AmeriCorps Cape Cod

Barnstable County, Regional Government of Cape Cod

Placed with: Harwich Cemetery Department & Center for Coastal Studies

 Email madeline.oerth@barnstablecounty.org |

<Outlook-mypjaatl.png>

Mobile (267)-907-5356

 [3195 Main Street | P.O. Box 427 | Barnstable, MA 02630](#)

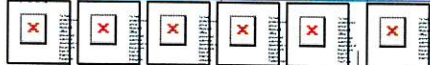

www.americorpscapedcod.org

Robbin Kelley

From: Lynne Drummond <lynnedrummond@comcast.net>
Sent: Tuesday, July 19, 2022 7:25 PM
To: Madeline Oerth
Cc: Gerie Schumann; dcoombes58@hotmail.com; sandyconcanon@gmail.com; lwu429@gmail.com; barbaras.harrison128@gmail.com; ejsully@comcast.net; sknowles45@gmail.com; pdwatson2@gmail.com; skaysmith@comcast.net; teresakatuska@gmail.com; amy9nat@aol.com; rblofgren@gmail.com; diverioa@yahoo.com; capepowers@comcast.net; pmcrocker@yahoo.com; notjustcapecodart@me.com; Robbin Kelley; Jodi Monroe
Subject: Re: 07/19 Tree Tour Followup

It was a pleasure and so informative!!

Sent from my iPhone

On Jul 19, 2022, at 2:39 PM, Madeline Oerth <madeline.oerth@barnstablecounty.org> wrote:

Hi Everyone!

Thank you so much for joining us on our tree tour in the James G. Marceline Arboretum at Island Pond Cemetery! I hope you all enjoyed your visit with us and learned a lot! If anyone is interested in volunteering with us in the future, please don't hesitate to reach out to Robbin at rkelley@town.harwich.ma.us. As you may have seen today, the arboretum requires a lot of maintenance (weeding, watering, etc.), so any help would be greatly appreciated! We hope to see you all again sometime soon!

It has truly been a pleasure serving the town of Harwich this year! Thank you!

Best,
Maddy

<Outlook-cpqnibw1.png>

Madeline Oerth

Pronouns: she/her

AmeriCorps Member | AmeriCorps Cape Cod

Barnstable County, Regional Government of Cape Cod

Placed with: Harwich Cemetery Department & Center for Coastal Studies

 Email madeline.oerth@barnstablecounty.org |

<Outlook-mypjaatl.png>

Mobile (267)-907-5356

 [3195 Main Street | P.O. Box 427 | Barnstable, MA 02630](#)



www.americorpscaped.org

Robbin Kelley

From: Pat Watson <pdwatson2@gmail.com>
Sent: Wednesday, July 20, 2022 8:35 AM
To: Eileen Sullivan
Cc: Madeline Oerth; Gerie Schumann; dcoombes58@hotmail.com; sandyconcannon@gmail.com; lwu429@gmail.com; barbars.harrison128@gmail.com; sknowles45@gmail.com; lynn Drummond@comcast.net; skaysmith@comcast.net; teresakatuska@gmail.com; amy9nat@aol.com; rblofgren@gmail.com; diverioa@yahoo.com; capepowers@comcast.net; pmcrocker@yahoo.com; notjustcapecodart@me.com; Robbin Kelley; Jodi Monroe
Subject: Re: 07/19 Tree Tour Followup

Thank you for the informative tour! I really enjoyed it, especially seeing the Mimosa tree.

Pat Watson

Sent from my iPhone

On Jul 20, 2022, at 8:05 AM, Eileen Sullivan <ejsully@comcast.net> wrote:

Thank you for a wonderful tour.
Eileen

Sent from my iPhone

On Jul 19, 2022, at 2:39 PM, Madeline Oerth
<madeline.oerth@barnstablecounty.org> wrote:

Hi Everyone!

Thank you so much for joining us on our tree tour in the James G. Marcelline Arboretum at Island Pond Cemetery! I hope you all enjoyed your visit with us and learned a lot! If anyone is interested in volunteering with us in the future, please don't hesitate to reach out to Robbin at rkelley@town.harwich.ma.us. As you may have seen today, the arboretum requires a lot of maintenance (weeding, watering, etc.), so any help would be greatly appreciated! We hope to see you all again sometime soon!

It has truly been a pleasure serving the town of Harwich this year! Thank you!

Best,
Maddy