

Town of Harwich  
BOARD OF WATER/WASTEWATER COMMISSIONER'S MEETING AGENDA\*  
Thursday, September 24, 2020, 1:00 pm

**REMOTE PARTICIPATION ONLY**  
**OPEN PUBLIC FORUM**

For those members of the public wishing to make comment you may do so by a combination of email and phone by;

1. First, send an email to: **dpelletier@harwichwater.com**  
(Send emails at any time after the meeting agenda has been officially posted)
  - a. In the subject line enter "request to speak Jane Doe"
  - b. Replace Jane Doe with your name - No need to add any more detail to email
2. Please wait until the Chairman has opened this agenda item for Open Public Forum
3. **Dial: 1 (224) 501-3412**
4. **Enter Access Code: 666-450-373**
5. Please be patient and eliminate any background noise
6. Callers will be taken in the order the emails are received
7. When your name is called use \*6 to unmute yourself

I. CALL TO ORDER

II. CONSENT AGENDA

A. Minutes

1. August 12, 2020

III. ABATEMENTS

IV. OLD/UNFINISHED BUSINESS

A. Laborer Hiring- *Update*

V. NEW BUSINESS

- A. FY21 Budget and Article Review for ATM
- B. FY20 Free Cash Certification- *Update*
- C. 20 Ton Trailer Bid- *Recommendation to Award*

VI. SUPERINTENDENT'S REPORT

- A. Flushing- *Tentative start October 5th, 2020*
- B. DWSP Grant
- C. Great Western Rd- *Update*

VII. COMMISSIONER'S REPORT

VIII. CORRESPONDENCE/ANY OTHER BUSINESS

IX. NEXT MEETING: TBD

X. OPEN PUBLIC FORUM

- A. See dial in instructions above

XII. ADJOURNMENT

*\*Per the Attorney General's Office: The Board of Water Commissioners may hold an open session for topics not reasonably anticipated by the Chair 48 hours in advance of the meeting following "New Business." \*If you are deaf or hard of hearing or are a person with a disability who requires an accommodation, contact the Water Department Office at 508-432-0304 x.0 or by email at [customerservice@harwichwater.com](mailto:customerservice@harwichwater.com)*

Authorized Posting Officer:  
Tracey Alves  
Tracey Alves, Board Secretary

Posted By: \_\_\_\_\_  
Town Clerk  
Date: \_\_\_\_\_

## II. CONSENT AGENDA

### A. Minutes

#### 1. August 12, 2020

**MINUTES  
HARWICH WATER DEPARTMENT  
BOARD OF WATER COMMISSIONERS  
WEDNESDAY, AUGUST 12, 2020  
1:00 P.M.**

**WATER COMMISSIONER'S PRESENT:** Chair Gary Carreiro, Vice Chair Judith Underwood, Clerk Allin Thompson

**OTHERS PRESENT:** Superintendent Dan Pelletier

**CALL TO ORDER**

Chair Carreiro called the meeting to order at 1:18 p.m.

**CONSENT AGENDA**

**A. Minutes:**

**1. July 31, 2020**

The minutes of July 31, 2020 were not ready and will be added to the next agenda.

**OLD UNFINISHED BUSINESS**

**A. Pleasant Lake Tank Upgrade Project Design Contracts**

Superintendent Pelletier provided the Board with an overview regarding the contracts for GHD and TIC.

Clerk Thompson moved to approve the contracts pending corporate certification by the Commonwealth, all of the Commissioners will sign. Vice Chair Underwood seconded the motion. Roll call vote was taken with all in favor; 3-0-0.

**B. Water Commission's Authority over Department Staff**

The Water Commission's Authority over Department staff was discussed. The Board will make a list and determine what their goals are in order for modifications to be made. This topic will remain on the agenda.

**C. Water Rates**

New water rate increase scenarios were discussed. The Board will choose their top three favorite scenarios, to be presented at the next meeting.

**NEW BUSINESS**

**A. Wastewater**

The topic of Wastewater will remain on the agenda until the next meeting.

**B. Bid Extension Letter; Ti Sales**

Clerk Thompson moved to approve the bid extension and authorize the Chair to sign. Vice Chair Underwood seconded the motion. Role call vote was taken with all in favor; 3-0-0.

**SUPERINTENDENT'S REPORT**

Superintendent Pelletier reported that Monday, July 27, 2020 was a record pumping day in the history of the Department at 6.58 million gallons.

**COMMISSIONER'S REPORT**

The Department's permit for water withdrawal was discussed.

**NEXT MEETING**

The next Board meeting date will be Friday, August 28, 2020 at 1:00 p.m.

**ADJOURNMENT**

Chair Carreiro motioned to adjourn at 1:49 pm. Clerk Thompson moved the motion with a second by Chair Carreiro. Roll call vote was taken, all in favor; 3-0-0.

\_\_\_\_\_  
Gary Carreiro, Chairman

\_\_\_\_\_  
Dan Pelletier, Superintendent

\_\_\_\_\_  
Judith Underwood, Vice Chair

\_\_\_\_\_  
Tracey Alves, Board Secretary

\_\_\_\_\_  
Allin P. Thompson, Clerk

## V. NEW BUSINESS

### A. FY21 Budget and Article Review for ATM

Article 8. Water Department Budget

Article 9. Wastewater/Sewer Budget

Article 39. Fund Prior Year's Unpaid Bills



**ANNUAL TOWN MEETING  
WARRANT  
With  
RECOMMENDATIONS**

**Saturday, September 26, 2020  
10:00AM**

**BUDGETS**

**ARTICLE 8.** Water Department Budget .....12

**ARTICLE 9.** Wastewater / Sewer Department Budget .....12

**REVOLVING FUNDS/PRIOR YEAR BILLS**

**ARTICLE 39.** Fund Prior Year's Unpaid Bills .....37

Item 3; \$1,500 Tighe & Bond Water Rate Study

Item 4; \$2,250 Tighe & Bond Water Rate Study

**WATER DEPARTMENT BUDGET**

**ARTICLE 8:** To see if the Town will vote to raise and appropriate, transfer from available funds or borrow such sums of money as may be required to defray the Water Department Operating Budget for Fiscal Year 2021, and to act fully thereon. By request of the Water and Wastewater Commission. Estimated cost: \$4,291,075.

<b>Water Operating Budget</b>	
Salaries	1,321,050
Expenses	1,468,390
Debt	721,345
Indirect Costs	730,290
OPEB	50,000
<b>Total</b>	<b>4,291,075</b>

**THE FINANCE COMMITTEE RECOMMENDS THIS ARTICLE BE ACCEPTED AND ADOPTED TO FUND THE ANNUAL OPERATION OF THE WATER DEPARTMENT AND THAT \$4,291,075.00 FROM WATER RECEIPTS BE USED FOR THIS PURPOSE. THIS IS A REDUCED BUDGET FROM LAST YEAR.**

**VOTE: YES-7, NO-0**

**The Board of Selectmen Recommends: 3-0**

**WASTEWATER / SEWER DEPARTMENT BUDGET**

**ARTICLE 9:** To see if the Town will vote to raise and appropriate, transfer from available funds or borrow such sums of money as may be required to defray the Wastewater/Sewer Department Operating Budget for Fiscal Year 2021, and to act fully thereon. By request of the Water and Wastewater Commission. Estimated cost: \$272,932.

Sewer Operating Budget	
Salaries	80,489
Expenses	192,443
<b>Total</b>	<b>272,932</b>

**THE FINANCE COMMITTEE RECOMMENDS THIS ARTICLE BE ACCEPTED AND ADOPTED TO FUND THE FY 2021 WATER SEWER OPERATING BUDGET AND THAT \$272,932.00 BE USED FOR THIS PURPOSE WITH \$100,000.00 BEING RAISED AND APPROPRIATED, AND \$100,000.00 COMING FROM FREE CASH, AND \$72,932 COMING FROM RETAINED EARNINGS OF THE DEPARTMENT. FLOWS WILL BE GOING TO THE CHATHAM TREATMENT PLANT THIS YEAR AND THE COST OF TREATMENT FOR THE TOWN WILL BEGIN.**

**VOTE: YES-8, NO-0**

**The Board of Selectmen Recommends: 5-0**

**FUND PRIOR YEAR'S UNPAID BILLS**

**ARTICLE 39:** To see if the Town will vote to raise and appropriate or transfer from available funds a sufficient sum of money to pay unpaid bills of prior years as provided for in M.G.L. Ch. 44, Section 64, and to act fully thereon. By request of the Finance Director. Estimated cost: \$7,595.83

	<b>Invoice/Debt</b>	<b>Description</b>	<b>Amount</b>	<b>Source</b>
1	Monomoy Regional High School	After Prom Planning Committee Contribution	\$2,500.00	Free Cash
2	Eastward Companies	Saquatucket Harbor Redevelopment Project Extra	\$ 942.87	Free Cash
3	Tighe & Bond	Water Rate Study	\$1,500.00	Retained Earnings for Water
4	Tighe & Bond	Water Rate Study	\$2,250.00	Retained Earnings for Water
5	WB Mason	Selectmen's Office Ordinary Office Supplies	\$ 35.79	Free Cash
6	Motorola Solutions	Police Department Repairs - Portable	\$ 367.17	Free Cash
		<b>Total:</b>	<b>\$7,595.83</b>	

**FINANCE COMMITTEE RECOMMENDS THIS ARTICLE BE ACCEPTED AND ADOPTED TO ALLOW VENDORS WHO HAVE PROVIDED GOODS AND SERVICES TO THE TOWN BUT HAVE NOT BEEN PAID. THIS YEAR 5 DIFFERENT VENDORS ARE DUE A TOTAL OF \$7,595.83 FROM 6 DIFFERENT INVOICES.**

**VOTE: YES-8, NO-0**



FY21 WATER BUDGET



09/23/2020 12:49  
scummings

TOWN OF HARWICH - LIVE DATA  
NEXT YEAR / CURRENT YEAR BUDGET ANALYSIS

P 1  
bgnyrpts

PROJECTION: 20211 2021 OPERATING BUDGET

FOR PERIOD 99

ACCOUNTS FOR:

WATER	ENTERPRISE FUND	2020 ACTUAL	2021 ORIG BUD	2021 REVISED BUD	2021 ACTUAL	2021 PROJECTION	2022 SELECTMEN	PCT CHANGE
1320	WATER ENTERPRISE FUND							
1320	596000 OFUS/INDIRECTS	720,295.00	.00	.00	.00	.00	730,290.00	.0%
TOTAL WATER ENTERPRISE FUND		720,295.00	.00	.00	.00	.00	730,290.00	.0%
13204501	WATER ENTERP SALARIES & WAGES							
13204501	511100 S&WELECTED	3,000.00	.00	.00	500.10	.00	3,000.00	.0%
13204501	511900 S&W	1,000,820.51	.00	.00	202,818.56	.00	990,575.07	.0%
13204501	512000 SEAS S & W	18,768.75	.00	.00	12,241.25	.00	45,696.00	.0%
13204501	513000 OVERTIME	197,202.63	.00	.00	40,071.68	.00	211,282.00	.0%
13204501	513060 FLUSHING	.00	.00	.00	.00	.00	31,919.00	.0%
13204501	514000 LONGEVITY	34,838.34	.00	.00	4,154.38	.00	35,253.00	.0%
13204501	515007 SCKLVBONUS	1,442.80	.00	.00	1,675.00	.00	3,325.00	.0%
TOTAL WATER ENTERP SALARIES		1,256,073.03	.00	.00	261,460.97	.00	1,321,050.07	.0%
13204502	WATER ENTERPRISE FUND EXP							
13204502	517900 OTHER FRIN	8,567.70	.00	.00	1,273.37	.00	8,250.00	.0%
13204502	521100 ELECTRIC	301,617.00	.00	.00	136,246.00	.00	328,126.00	.0%
13204502	521200 GAS	6,993.07	.00	.00	177.72	.00	9,535.00	.0%
13204502	524140 V&EMAIINT	30,350.87	.00	.00	5,173.83	.00	58,500.00	.0%
13204502	524160 B&GMAINT	17,039.47	.00	.00	4,607.23	.00	45,000.00	.0%
13204502	525000 TECH SUP	26,240.39	.00	.00	16,975.22	.00	27,240.00	.0%
13204502	526000 BLDG AGRMT	7,565.50	.00	.00	6,639.30	.00	9,650.00	.0%
13204502	530800 LAB SVCS	12,095.00	.00	.00	2,162.00	.00	22,500.00	.0%

09/23/2020 12:49  
scummings

TOWN OF HARWICH - LIVE DATA  
NEXT YEAR / CURRENT YEAR BUDGET ANALYSIS

P 2  
bgnyrpts

PROJECTION: 20211 2021 OPERATING BUDGET

FOR PERIOD 99

ACCOUNTS FOR:

WATER	ENTERPRISE FUND		2020 ACTUAL	2021 ORIG BUD	2021 REVISED BUD	2021 ACTUAL	2021 PROJECTION	2022 SELECTMEN	PCT CHANGE
13204502	530820	PROFSVCS	16,484.21	.00	.00	3,940.00	.00	75,000.00	.0%
13204502	530875	PRINT SVC	9,394.28	.00	.00	2,101.00	.00	23,000.00	.0%
13204502	534100	ADV	1,039.80	.00	.00	600.00	.00	1,500.00	.0%
13204502	534300	POSTAGE	16,945.59	.00	.00	4,320.63	.00	21,000.00	.0%
13204502	534400	TELEPHONE	6,983.23	.00	.00	1,874.00	.00	7,700.00	.0%
13204502	534430	COMM SVCS	16,186.05	.00	.00	1,676.91	.00	16,000.00	.0%
13204502	541100	PROPANE	13,704.60	.00	.00	385.31	.00	18,944.00	.0%
13204502	542000	OFF SUPPLS	5,166.55	.00	.00	626.51	.00	5,900.00	.0%
13204502	542013	HARD/SOFT	23,058.78	.00	.00	.00	.00	25,924.00	.0%
13204502	548100	BULK FUEL	23,014.53	.00	.00	.00	.00	28,371.00	.0%
13204502	548200	TREAT SUPP	18,877.65	.00	.00	5,457.60	.00	27,500.00	.0%
13204502	548250	TREAT CHEM	136,655.18	.00	.00	166,202.89	.00	145,000.00	.0%
13204502	553000	P.W. SUPPL	9,634.94	.00	.00	2,512.51	.00	26,250.00	.0%
13204502	553100	METERS	137,763.10	.00	.00	6,276.39	.00	180,000.00	.0%
13204502	553200	INSTALLSUP	35,194.52	.00	.00	32,235.34	.00	43,000.00	.0%
13204502	553300	PIPESETC	76,636.56	.00	.00	70,838.07	.00	90,000.00	.0%
13204502	553350	MAINREPL	500.00	.00	.00	.00	.00	35,000.00	.0%
13204502	553500	DETAILS	26,095.59	.00	.00	608.00	.00	60,000.00	.0%
13204502	553600	RDREP	31,733.35	.00	.00	13,029.06	.00	33,000.00	.0%
13204502	553900	MECHTANK	3,990.00	.00	.00	1,980.00	.00	10,000.00	.0%
13204502	554200	GENERMAINT	9,658.37	.00	.00	6,784.95	.00	12,500.00	.0%
13204502	554300	WELLREHAB	3,173.00	.00	.00	.00	.00	45,000.00	.0%

09/23/2020 12:49  
scummings

TOWN OF HARWICH - LIVE DATA  
NEXT YEAR / CURRENT YEAR BUDGET ANALYSIS

P 3  
bgnyrpts

PROJECTION: 20211 2021 OPERATING BUDGET

FOR PERIOD 99

ACCOUNTS FOR:

WATER	ENTERPRISE FUND		2020 ACTUAL	2021 ORIG BUD	2021 REVISED BUD	2021 ACTUAL	2021 PROJECTION	2022 SELECTMEN	PCT CHANGE
13204502	558100	UNIFORMS	4,132.39	.00	.00	124.31	.00	6,500.00	.0%
13204502	573000	DUE, SB, TRV	13,921.58	.00	.00	1,241.16	.00	14,000.00	.0%
13204502	573200	WATPERMIT	5,943.25	.00	.00	.00	.00	8,500.00	.0%
13204502	575070	OPEB	50,000.00	.00	.00	.00	.00	50,000.00	.0%
13204502	591000	MAT.LT.DBT	550,912.57	.00	.00	15,618.34	.00	547,800.00	.0%
13204502	591500	INT LT DBT	187,543.68	.00	.00	19,902.25	721,345	171,199.00	.0%
13204502	591550	ADM FEE LT	1,232.06	.00	.00	1,171.38	.00	2,346.00	.0%
TOTAL WATER ENTERPRISE FUND			1,846,044.41	.00	.00	532,761.28	.00	2,239,735.00	.0%
13204504	WATER REVENUE ENTERP FUND						EXPENSES	1,468,390.00	excl. Debt/OPEB
13204504	414600	WATER LIEN	-11,400.12	.00	.00	-1,912.48	.00	-20,241.00	.0%
13204504	417008	P&I WATER	-2,615.58	.00	.00	-134.63	.00	-2,211.00	.0%
13204504	421100	WATER R&S	-3,672,392.20	.00	.00	-854,156.70	-3,331,120.00	-4,384,189.00	.0%
13204504	421200	METERS	-6,565.09	.00	.00	-1,599.70	.00	-10,834.00	.0%
13204504	421300	SVCAPPL	-2,060.00	.00	.00	.00	.00	-2,168.00	.0%
13204504	421400	SVINSTALL	-139,067.37	.00	.00	-58,409.83	.00	-168,982.00	.0%
13204504	421450	MKOUTSVC	-6,877.58	.00	.00	-20,417.64	.00	-3,241.00	.0%
13204504	421550	PROPTRAN	-22,770.00	.00	.00	-5,946.44	.00	-10,903.00	.0%
13204504	421600	WIRELESS	-126,373.22	.00	.00	-42,715.49	.00	-128,341.00	.0%
13204504	421650	SOLREV	-104,081.26	.00	.00	-23,324.45	.00	-70,562.00	.0%
13204504	431100	SVC TIGHT	-76,900.13	.00	.00	-21,521.67	.00	-82,076.00	.0%
13204504	433007	LATE FEE	-39,443.60	.00	.00	-16,225.01	.00	-48,771.00	.0%
13204504	451100	BACKFLOW	-8,578.71	.00	.00	-7,175.02	.00	-20,366.00	.0%



09/23/2020 12:49  
scummings

TOWN OF HARWICH - LIVE DATA  
NEXT YEAR / CURRENT YEAR BUDGET ANALYSIS

P 4  
bgnyrpts

PROJECTION: 20211 2021 OPERATING BUDGET

FOR PERIOD 99

ACCOUNTS FOR:

WATER	ENTERPRISE FUND		2020 ACTUAL	2021 ORIG BUD	2021 REVISED BUD	2021 ACTUAL	2021 PROJECTION	2022 SELECTMEN	PCT CHANGE
13204504	482001	INVEST REV	-25,086.18	.00	.00	.00	.00	-21,200.00	.0%
13204504	484099	WATER MISC	-41,739.78	.00	.00	-16,861.07	.00	-54,331.00	.0%
TOTAL WATER REVENUE ENTERP F			-4,285,950.82	.00	.00	-1,070,400.13	-3,331,120.00	-5,028,416.00	.0%
TOTAL WATER ENTERPRISE FUND			-463,538.38	.00	.00	-276,177.88	-3,331,120.00	-737,340.93	.0%
TOTAL REVENUE			-4,285,950.82	.00	.00	-1,070,400.13	-3,331,120.00	-5,028,416.00	.0%
TOTAL EXPENSE			3,822,412.44	.00	.00	794,222.25	.00	4,291,075.07	.0%
GRAND TOTAL			-463,538.38	.00	.00	-276,177.88	-3,331,120.00	-737,340.93	.0%

\*\* END OF REPORT - Generated by Sandy Cummings \*\*



09/23/2020 13:05  
scummings

TOWN OF HARWICH - LIVE DATA  
NEXT YEAR / CURRENT YEAR BUDGET ANALYSIS

P 1  
bgnyrpts

PROJECTION: 2021 2021 OPERATING BUDGET

FOR PERIOD 99

ACCOUNTS FOR:

WASTEWATER ENTERPRISE	2020 ACTUAL	2021 ORIG BUD	2021 REVISED BUD	2021 ACTUAL	2021 PROJECTION	2022 SELECTMEN	PCT CHANGE
13304401 SEWER SALARIES & WAGES							
13304401 511900 S&W	.00	.00	.00	.00	.00	77,284.93	.0%
TOTAL SEWER SALARIES & WAGES	.00	.00	.00	.00	.00	77,284.93	.0%
TOTAL WASTEWATER ENTERPRISE	.00	.00	.00	.00	.00	77,284.93	.0%
TOTAL REVENUE	.00	.00	.00	.00	.00	.00	.0%
TOTAL EXPENSE	.00	.00	.00	.00	.00	77,284.93	.0%
GRAND TOTAL	.00	.00	.00	.00	.00	77,284.93	.0%

\*\* END OF REPORT - Generated by Sandy Cummings \*\*



Sewer Operating Budget		FY21 HARWICH BUDGET
Operating Expenses		
<b>A</b>	<b>Personal Services</b>	
IMA	Regular Wages	\$3,204.04
HAR	Superintendent	\$63,866.79
HAR	HWD Support (Admin & Meter Reading)	\$13,418.14
<b>A</b>	<b>Salaries</b>	<b>\$80,488.97</b>
<b>B</b>	<b>Expenses</b>	
IMA	Testing	\$39.03
IMA	Electric WWFT	\$289.04
IMA	Gas Heat	\$72.79
IMA	Plant Maintenance	\$16,733.00
IMA	Solid Waste Disposal	\$158.23
IMA	Contract Services	\$67,393.60
IMA	Operational Supplies	\$86.55
IMA	Building & Grounds Maintenance	\$28.85
IMA	Chemicals	\$84.39
IMA	Ground Water Monitoring	\$2,308.00
HAR	Contract Operations	\$100,000.00
HAR	Generator Maintenance	
HAR	Electric Utility	\$4,000.00
HAR	Nat Gas	\$600.00
HAR	Printing & Postage & Office Services	\$650.00
HAR	SCADA	
<b>B</b>	<b>Expenses</b>	<b>\$192,443.48</b>
<b>Department Total</b>		
<b>TOTAL</b>	<b>Operating Expense</b>	<b>\$272,932.45</b>

ARTICLE 39

Tighe & Bond Contract \$15,000 (8/13/18)

**From:** [Carol Coppola](#)  
**To:** [Sandra Sieger](#)  
**Subject:** RE: Prior Year Invoices  
**Date:** Monday, March 2, 2020 3:43:17 PM

Unpaid:  
Invoice 121897206 \$1,500.00  
Invoice 021997215 \$2,250.00

---

Hi Sandy,

Both of these invoices will need to be paid a prior year bills, we will need to put them on the warrant for May Town Meeting. I assume you will be paying them from retained earnings? YES

Carol

**From:** Sandra Sieger [mailto:ssieger@harwichwater.com]

**Sent:** Monday, March 02, 2020 2:11 PM

**To:** Carol Coppola <ccoppola@town.harwich.ma.us>

**Subject:** Prior Year Invoices

Hi Carol,

I was just notified last week of two Tighe & Bond outstanding invoices dated February 2019. I had not received these invoices prior or they would have been paid prior to 7/1/19 or placed on an Accrual request. Can these be placed on town warrant for prior years bills or is it possible to pay them out of our current year budget.

Thank you,

Sandy

Sandra Cummings Sieger | Comptroller

Harwich Water Department | 508.432.0304 x103

Town of Harwich, Massachusetts

---

---

## V. NEW BUSINESS

### B. FY20 Free Cash Certification

Water Enterprise Fund

Sewer Enterprise Fund

SUBMITTED BY Carol Coppola  
FIELD REP Katie Scopelleti

COMMUNITY Harwich  
FUND Water

**RETAINED EARNINGS CALCULATION - ENTERPRISE FUND**

**PART I**

CASH 1,855,782

SUBTRACT:

CURRENT LIABILITIES, DESIGNATIONS OF FUND BALANCE

Warrants Payable	_____	_____
Encumbrances	_____	_____
Expenditures	_____	_____
Accounts Payable	_____	34,001
Continuing Appropriations	_____	392,047
_____	_____	_____
_____	_____	_____
_____	_____	_____

TOTAL 1,429,733

**PART II**

RETAINED EARNINGS - UNDESIGNATED 1,429,733

SUBTRACT:

ACCOUNTS RECEIVABLE (NET)

_____	_____
_____	_____
_____	_____
_____	_____
_____	_____
_____	_____
_____	_____
_____	_____

TOTAL 1,429,733

**PART III**

**FIXED ASSETS:**

DEBITS

CREDITS

_____	_____	_____	_____
_____	_____	_____	_____
_____	_____	_____	_____
_____	_____	_____	_____
Total	_____	_____	_____
FIXED ASSET VARIANCE	_____	_____	_____

REVIEWED BY: Katie Scopelleti

PLEASE SEE CERTIFICATION LETTER

DATE: 09/15/20

FOR DIRECTOR OF ACCOUNTS APPROVAL

SUBMITTED BY Carol Coppola  
FIELD REP Katie Scopelleti

COMMUNITY Harwich  
FUND Sewer

**RETAINED EARNINGS CALCULATION - ENTERPRISE FUND**

**PART I**

CASH 271,913

SUBTRACT:

CURRENT LIABILITIES, DESIGNATIONS OF FUND BALANCE

Warrants Payable

Encumbrances

Expenditures

TOTAL 271,913

**PART II**

RETAINED EARNINGS - UNDESIGNATED 271,913

SUBTRACT:

ACCOUNTS RECEIVABLE (NET)

TOTAL 271,913

**PART III**

FIXED ASSETS:

DEBITS

CREDITS

\_\_\_\_\_

\_\_\_\_\_

\_\_\_\_\_

\_\_\_\_\_

Total \_\_\_\_\_

FIXED ASSET VARIANCE \_\_\_\_\_

REVIEWED BY:

*Katie Scopelleti*

PLEASE SEE CERTIFICATION LETTER

DATE:

09/15/20

FOR DIRECTOR OF ACCOUNTS APPROVAL



## V. NEW BUSINESS

### C. 20-Ton Trailer Bid

Hale Trailer Brake & Wheel

**Schmidt Equipment, Inc.** - Recommendation

Robert Childs, Inc.



# Town of Harwich Water Department

196 Chatham Road, Harwich, MA 02645 USA \* [www.harwichwater.com](http://www.harwichwater.com)  
P. 508-432-0304 \* F. 888-774-3557 \* [Dpelletier@harwichwater.com](mailto:Dpelletier@harwichwater.com)

## Memorandum

To: Board of Water & Wastewater Commissioners  
From: Dan Pelletier, Superintendent of Water & Wastewater  
RE: Recommendation to Award – 20-Ton Trailer  
Date: 9/23/2020

---

At the July 31<sup>st</sup>, 2020 Board of Water & Wastewater Commissioners meeting the Board authorized the replacement of the departments 1997 Dove Equipment Trailer due to mechanical failures & cost prohibitive repairs. Procurement for a new 20-Ton Tag Along trailer was conducted under the provisions of M.G.L. c. 30B. Specifications and Request for Quotes were solicited from the following 3 vendors:

Bidder	Proposed Trailer	Bid
Hale Trailer Brake & Wheel 32 Industrial Road Walpole, MA 02081	Talbert Manufacturing, Inc. AC-20-AR	\$24,000.00
<b>Schmidt Equipment Inc.</b> <b>80 Southbridge Rd.</b> <b>PO Box 578</b> <b>North Oxford, MA 01537</b>	<b>Interstate</b> <b>40DLA</b>	<b>\$22,180.00</b>
Robert Childs, Inc. PO Box 1431 South Dennis, MA 02660	CAM Superline 20CAM8225TA	\$26,100.00

The trailer plays a pivotal role transporting heavy equipment in support of the departments day-to-day operations, delaying its replacement would have a detrimental effect on our ability to respond. **As such, I recommend the amount of \$22,180 be internally transferred from the Meters/Read Devices & Supplies line item to the Vehicle/Equipment Maintenance line item for the purchase of a new 20-Ton Tag Along trailer. Furthermore, I recommend the Board of Water & Wastewater Commissioners vote to award Schmidt Equipment Inc. a contract in the amount of \$22,180 for a new 2020 Interstate 40DLA Trailer.**

Respectfully,

Daniel R. Pelletier  
Town of Harwich  
Superintendent of Water & Wastewater



September 14, 2020

TOWN OF HARWICH WATER DEPARTMENT  
Attn: Dan Pelletier  
Superintendent  
RFQ-20 TON TRAILER

Dear Dan:

Hale Trailer Brake & Wheel is a full service trailer dealership that sells new and used trailers and related equipment. Hale also rents trailers on a short and long term basis, sells commercial trailer parts and accessories and provides general service and repairs to trailer equipment.

I would like to thank you for the opportunity to Town of Harwich Water Department on the following TALBERT 20 TON TAG A LONG TRAILER.

**2021 TALBERT 20 TON TAG A LONG TRAILER:**

**Price: \$24000**

**\*see attached detailed spec**

**FOB WALPOLE, MA  
DOES NOT INCLUDE ANY TAX, FET OR STATE**

Sincerely,

A handwritten signature in black ink, appearing to read "Joe Gurnick".

Joe Gurnick  
Branch Manager  
jgurnick@haletrailer.com

# HALE

## TRAILER

### BRAKE & WHEEL

## Hale Trailer Brake & Wheel

### 040691-040693

### Talbert Manufacturing, Inc.

Model: AC-20-AR  
Capacity in tons: 20

#### 1. TONGUE

Pintle eye Adjustable pintle eye (3" ID) with 48" chain and grab hooks  
Tongue 5'-6" with lockable tool box with aluminum diamond plate lid - move hinge 4" forward  
Drop leg 2-speed, 50,000# crank down dual landing leg, mounted to main beams and headboard  
Electrical receptacle Seven pin connector  
Headboard 8" high full width

#### 2. DECK

Deck section design One piece tongue, main beam and beavertail (cold formed)  
Deck section length 27'-0" (21'-0" flat with 6'-0" beavertail)  
Deck section width 8'-6"  
Loaded deck height 32-1/4"  
Flooring 1-1/2" apitong  
Lash rings 10 total -  
4 each side on flat deck (straight style), 8 total  
1 each side on beavertail (straight style), 2 total  
Crossmembers 6" deep hi-tensile  
Mainbeams 12" deep hi-tensile  
Sidemembers 8" deep hi-tensile  
Beavertail 6'-0" with wood flooring full width  
Ramps 38" wide x 6'-0" long air ramps with wood flooring, stored vertically with lock bar

#### 3. RUNNING GEAR

Number of axles 2  
Axle capacity 25,000#, full width track  
Brakes 12-1/4" x 7-1/2" air with 2S/1M ABS. Spring brakes on both axles.  
Wheels Steel disc with oil seals (6.75 x 17.5)  
Tires Eight (8) 215/75R17.5 (H) 16PR radials  
Use valve stem extensions on inside wheels  
Suspension 44,800# Hutch spring

#### 4. GENERAL

Lights and wiring 12 volt LED system (license plate regular), supplied with female 7-way plug on tongue, SUPPLY JUMPER CORD FOR TRUCK  
Paint Valspar standard Talbert black  
Estimated empty weight 9,140#  
Additional general specifications Formed step in front of 1st axle both sides of trailer

#### DISCLAIMER

Specifications are believed to be correct, but may contain errors and/or omissions. Photographs are the representative of the subject equipment but may not be identical. Equipment availability, prices and specifications are subject to change without notice.





**JOHN DEERE**

**Main Office**

(Rt. 20) 80 Southbridge Rd.  
PO Box 578  
North Oxford, MA 01537  
Phone: (508) 987-8786  
Toll Free: (800) 922-8295  
Fax: (508) 987-3578

**Branch Offices**

- Rtes 6 & 136  
N Swansea, MA 02777
- 4 Sterling Rd.  
N Billerica, MA 01862
- 1620 Page Blvd. (Rt 20)  
Springfield, MA 01104
- 88 Camelot Dr. #42  
Plymouth, MA 02360

## 20 Ton Trailer Quote

To: Dan Pelletier, Harwich Water Department  
196 Chatham Road  
Harwich, MA 02568

From: Joe Huber  
Schmidt Equipment, Inc.  
508-989-2750

Date: 09/11/120

Reference: RFQ request for 9/15/2020

***New 2020 Interstate 40DLA trailer with these standard features & requested options:***

- Load capacity – 40,000 lbs. at 65 M.P.H.  
(G.V.W.R. 47,600 lbs.)
- 32' overall length, 8'6" wide, 36" deck height
- 21' deck (extra 2' needed for air ramps) with  
5' beavertail and 7' x 3' air ramps
- 2 axles with air brakes, Wabco anti-lock  
system and spring parking brakes
- 44,000 lb. Hutch 9700 spring suspension
- 2" nominal oak deck, wood filled ramps
- 12 volt LED lights, rubber mounted
- Pierced main-beam frame construction  
w/one piece interlocking members
- Tires - 215/75R17.5 with 8-hole hub  
piloted steel disc wheels
- Dual 2-speed landing gear/jacks
- 8 HD tie down "D" rings
- 4 position steel pintle ring
- Black urethane paint with rust prohibited  
undercoating
- 7-way sealed connector plug

Trailer list price (includes factory freight, delivery and dealer prep):	\$23,850.00
Less Dealer municipal 7% discount:	<u>(\$1,670.00)</u>
<b>Total delivered trailer cost:</b>	<b>\$22,180.00</b>

**Notes:** A similarly equipped **Eager Beaver model 20XPT** trailer would be **\$24,890** including dealer municipal discount. Estimated ETA for either trailer is 10 weeks from date of order.

We appreciate the opportunity to provide this quote and look forward to being able to supply the Town of Harwich Water Department with a new trailer. If there are any questions relative to this quote, please call me at 508-989-2750, or Mike Cheney at 508-987-8786.

Thank you for the opportunity to quote this trailer,

Joe Huber  
Schmidt Equipment, Inc.



# **INTERSTATE**



## **40DLA**

**THE  
DEFINITION  
OF VALUE**

**CONTINUOUS PIERCED  
MAIN BEAM WITH  
INTERLOCKING  
CROSSMEMBERS  
SYSTEM**

**SEALED BEAM  
ELECTRICAL SYSTEM**

**HEAVY DUTY AIR  
BRAKES**

**HEAVY DUTY SPRING  
SUSPENSION**

**FRONT HEAD  
BOARD STOP**

**UNDERCOATED**



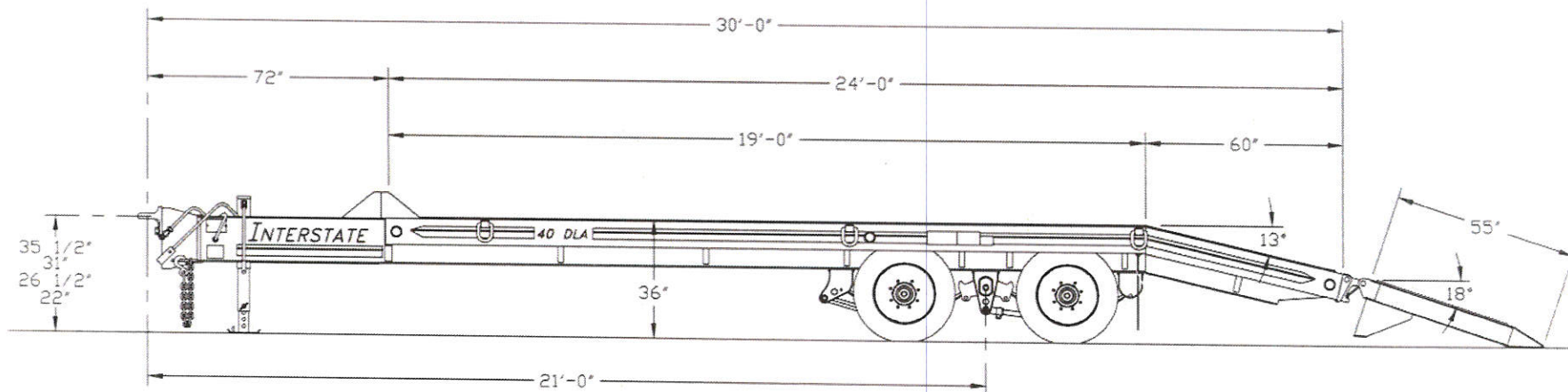

## MODEL 40DLA

CAPACITY: 40,000# @ 55 MPH  
 Trailer Weight: 7,600#  
 Overall Length: 30' 0"  
 Overall Width: 96"/102"  
 Platform Length: 24' 0"  
 Platform Height: 36"  
 Dovetail Length: 60"  
 Ramp Length: 55"  
 Ramp Width: 22 1/2"  
 Decking: 2" Nominal Hardwood

Main Rails: W14" x 22# A572 Gr. 50 High Tensile  
 Crossmembers: 6" Jr. I-Beam A572 Gr. 50 High Tensile  
 Heavy Duty Axles: (2) 22,500#  
 Heavy Duty Brakes: 12 1/4" x 7 1/2" Air - ABS  
 Heavy Duty Suspension: H9700  
 Tires: (8) 215/75R x 17.5 - 16 Ply Radial  
 Heavy Duty Wheels: 8 Hole, Hub Piloted  
 Lights & Electric: Sealed Beam System/ICC & DOT Approved  
 Hitch: Adjustable Pintle Eye  
 Heavy Duty Jack: 12,000# Drop Leg

Your **INTERSTATE** Dealer Is

# ROBERT CHILDS, INC.

P.O. BOX 1431  
169 GREAT WESTERN ROAD  
SOUTH DENNIS, MA 02660  
508-398-2556  
508-394-5317 fax

## Proposal

September 15, 2020

Town of Harwich Water Department  
Attn: Dan Pelletier  
196 Chatham Road  
Harwich, MA 02645  
Tel: 508-432-0304 ext. 110  
Cell (774) 722-7963  
[dpelletier@harwichwater.com](mailto:dpelletier@harwichwater.com)

One new 2020 CAM Superline Model 20CAM8225TA:	\$27,000.00
Serial No: 5JWCK2729LP508466	
Stock No: CM1550	
GVWR: 51750lbs. Empty: 9095lbs. Payload: 42655lbs.	
Color: Black	
Standard Length: 27' (22' Flat / 5' Beaver Tail)	
Options:	
30in x 80in Air Power Ramps Wood	
Air Brakes	
Sealed 7 Pin DOT Plug	
Adjustable Pintle Ring	
Dual 50K 2-Speed Jacks (Bolt-On)	
Nominal 2" Oak Deck	
LED Lights – Rubber Mounted	
Less Municipal Discount – Applied w/Hard Copy Purchase Order:	<u>(\$ 900.00)</u>
Total Purchase:	\$26,100.00

Warranty: Three Years Defects in Material and Workmanship Limited, 1 Year Tire Hazard, 5 Year Tire Defect, 5 Year Axle and Suspension, 1 Year Hydraulic Pump and Cylinder.



## SPECIFICATIONS PAGE

# 20 and 25 TON HEAVY DUTY DECKOVER TRAILER



## 20 and 25 TON HD DECKOVER STANDARD FEATURES

Steel Plated Tongue  
Hi-Tensile Steel Construction  
Full Pierced Beam Construction  
Adjustable Pintle Hitch  
Safety Chains (5/8" High Test)  
Sealed 7-Pin Plug w/ Arctic Flex Whip  
Zip Breakaway System  
Dual 50K 2-Speed Jacks (Bolt-On)  
Oil Bath Axles  
Axle Springs: 3 Leaf (50,000 lb. Capacity)  
Spring Park Brake On All Axles  
Hutch H-9700 Suspension

Silver Wheels  
Epoxy Primer  
Polyurethane Paint Finish  
Nominal 2" Oak Deck  
Spare Tire Mount (Under Bed)  
D-Ring Tie-Downs - 1" (12)  
Toolbox  
Mud Flaps  
Steps (4)  
Sealed Wiring Harness  
LED Lights - Rubber Mounted  
Three Year Warranty

*Specifications subject to change without notice.*







## SPECIFICATIONS PAGE

# 20 and 25 TON HEAVY DUTY DECKOVER TRAILER

	20' + 5' (Air)	24' + 5' (Air)
Model #	P20CAM8205TA	P25CAM8245TA
GVWR (lb.)	51750	65000
GAWR (lb. / Axle)	22500	22500
Curb Weight	9095	11575
Payload	42655	53425
Main Frame	14" I-Beam @ 22 lb	
Crossmembers	3" Channel	
Side Rail	8" Channel @ 11.5 lb	
Tongue	14" I-Beam @ 22 lb	
Beavertail	5' Beavertail	
Coupler	Adjustable Pintle Ring	
Jack	Dual 50K Bolt-On Drop Leg 2-Speed Jacks	
Axles	Oil Bath Axles	
Suspension	Hutch H-9700 Suspension	
Tires	235/75R17.5 LRH Dual	
Wheels	17.5" Dual	
Decking	Nominal 2" Oak Deck	
Lights	LED Lights - Rubber Mounted	
Electric Plug	Sealed 7 Pin Plug w/Arctic Flex Whip	
Finish	PPG Industrial Polyurethane Paint	
Overall Length	376"	424"
Deck Height	35"	
Coupler Height	21.5" - 30.5"	
Ramps	5' Bi-Directional Spring Assisted Wood Filled Ramps	

Specifications subject to change without notice.

