

SELECTMEN'S MEETING AGENDA*

Executive Session 6:00 P.M.

Regular Meeting 6:30 P.M.

Wednesday, March 24, 2021

REMOTE PARTICIPATION ONLY
OPEN PUBLIC FORUM – PLEASE READ

1. First, send an email to: comment@town.harwich.ma.us (send emails at any time after the meeting agenda has been officially posted)
 - a. In the subject line enter “request to speak, your name”
 - b. In the body of the email please indicate which specific agenda item you wish to speak on.
No further detail is necessary.
 2. The meeting will close to new attendees promptly at the scheduled start time for the meeting, generally 6:30pm. It will remain closed to new attendees until agenda items with scheduled speakers are reached. This is to minimize interruptions. You may join prior to (6:30) or when the meeting has been opened up. You may participate using your computer and the GoToMeeting interface or simply using your phone. Connection information can be found below.
 3. After the Chairman has opened the floor to those wishing to speak callers will be taken in the order the emails are received.
Use *6 to mute and unmute your phone
- When you join the meeting by phone you should turn off Channel 18 or your computer if streaming the meeting.

Please join my meeting from your computer, tablet or smartphone.

<https://global.gotomeeting.com/join/692090213>

You can also dial in using your phone.

United States: [+1 \(669\) 224-3412](tel:+16692243412)

Access Code: 692-090-213

I. **CALL TO ORDER**

II. **EXECUTIVE SESSION**

- A. Pursuant to M.G.L. c. 30A section 21 (a) paragraph 3 to discuss with respect to collective bargaining for Harwich Employees Association (HEA) if an open session would have a detrimental effect on the town's bargaining position and the Chair so declares
- B. Pursuant to MGL,c.30A section 21 (a) paragraph 3 to discuss with respect to collective bargaining for all town unions if an open session would have a detrimental effect on the town's bargaining position and the chair so declares;

III. **PLEDGE OF ALLEGIANCE**

IV. **WEEKLY BRIEFING**

- A. COVID-19 Updates
- B. Update on ongoing efforts by the Town in support of the business community

V. **PUBLIC COMMENTS/ANNOUNCEMENTS**

VI. **CONSENT AGENDA**

- A. Discussion and possible vote to approve a Caleb Chase request in the amount of \$1,000
- B. Discussion and possible vote to support the nomination of Jennifer Harrington as Animal Inspector
- C. Discussion and possible vote to accept a gift from Paul B. Manning of \$250,000 to support the Saquatucket Harbor to Harwich Port Sidewalk design

VII. **NEW BUSINESS**

- A. Discussion and possible vote – potential lease extension for 374 Main Street Bog
- B. Discussion and possible vote to appoint the Town Administrator as a voting member of Cape Cod Municipal Health Group (CCMHG)
- C. Discussion and possible vote to authorize the Chair to sign the Memorandum of Agreement between Harwich Council on Aging and the Social Security Administration
- D. Discussion and possible vote to approve Board of Selectmen Meeting Minutes
 1. June 17, 2019
 2. June 24, 2019
 3. October 15, 2019
- E. Discussion and possible vote – 2021 Seasonal All Alcohol Liquor license renewals
 1. 30 Earle Road LLC DBA The Commodore Inn – 30 Earle Road
 2. Wychmere Harbor Functions LP DBA Wychmere Harbor Beach and Tennis – 23 Snow Inn Road
 3. Pleasant Bay Group Inc. DBA Wequassett Inn – 173 Route 28
 4. Lucky Labrador Inc. DBA Perks – 545 Route 28
- F. Discussion and possible vote – 2021 Seasonal Wine and Malt Liquor license renewals
 1. Ajpg Corp. DBA The Weatherdeck Restaurant – 168 Route 28

VIII. **OLD BUSINESS**

- A. Discussion and possible vote – FY22 Monomoy Regional School District budget
- B. Discussion and possible vote to approve – Monomoy Regional School District Regional Assessment
- C. Discussion and possible vote – on all Articles in the draft Warrant for 2021 Annual Town Meeting;
 1. Vote to place Articles on Warrant
 2. Vote to withdraw Articles from draft Warrant
 3. Recommendation votes including, but not limited to, vote to recommend, accept and adopt or any other action
- D. Ongoing discussion – Comprehensive Wastewater Management Plan (CWMP)
 1. Discussion – GHD SewerCAD modeling kickoff

IX. **CONTRACTS**

- A. Discussion and possible vote for the Board of Selectmen to execute contract with Vermeer Mid Atlantic LLC for a Vermeer SC552 Stump Cutter \$60,039.00
- B. Discussion and possible vote for the Board of Selectmen to execute contract with Colonial Municipal Group for two (2) Police Cruisers for the Police Department for \$96,930.80

X. **TOWN ADMINISTRATOR'S REPORT**

XI. **SELECTMEN'S REPORT**

XII. **ADJOURNMENT**

**Per the Attorney General's Office: The Board of Selectmen may hold an open session for topics not reasonably anticipated by the Chair 48 hours in advance of the meeting following "New Business." If you are deaf or hard of hearing or a person with a disability who requires an accommodation contact the Selectmen's Office at 508-430-7513.*

Authorized Posting Officer:

Danielle Delaney, Executive Assistant

Posted by: _____
Town Clerk

Date: _____
March 19, 2021

WEEKLY BRIEFING



Town of Harwich Board of Health

732 Main Street Harwich, MA 02645
508-430-7509 – Fax 508-430-7531
E-mail: health@town.harwich.ma.us

March 22, 2021

Weekly COVID-19 Case Update

CASES AND STATISTICS

To date there have been a total of 606 cases of COVID-19 in the Town of Harwich. As of today, we are following 18 active cases of COVID-19 in Harwich residents. Our positivity rate has increased to 3.06% which is determined by the number of tests administered. Over the past two weeks there were 850 tests administered, and 26 tests were positive. We have been designated as “Yellow”, which indicates we have 10 or more averages cases per 100,000 people, or a greater than 5% positivity rate.

VACCINE UPDATE

Newly Eligible for Vaccine as of March 22, 2021:

- People who are 60 years or older
- Certain Workers
 - Restaurant or cafe workers, food workers, meatpacking, beverage, agriculture, consumer goods, retail, or food service workers, grocery and convenience store workers, food pantry workers or volunteers, medical supply chain workers, vaccine development workers, transit/transportation workers, public works, water, wastewater, or utility workers, sanitation workers, public health workers, court system workers, funeral directors and funeral workers. <https://www.mass.gov/info-details/covid-19-vaccinations-for-certain-workers>

Eligible as of April 5, 2021:

- People who are 55 years or older
- People with 1 certain medical condition
 - Asthma, Cancer, Chronic Kidney Disease, COPD, Down Syndrome, Heart Conditions, Immunocompromised State, Obesity and Severe Obesity, Pregnancy, Sickle Cell Disease, Smoking, Type 2 Diabetes.

Eligible as of April 19, 2021:

- If your group is not specifically listed in either Phase 1 or Phase 2, you will be eligible to receive the vaccine in Phase 3, which will launch April 19, 2021.

Currently Eligible Complete List:

Phase 1 listed in order of priority:

- Clinical and non-clinical health care workers doing direct and COVID-facing care
- Long term care facilities, rest homes and assisted living facilities
- First responders
- Congregate care settings
- Home-based health care workers
- Health care workers doing non-COVID-facing care

Phase 2 listed in order of priority:

- People who are 75 or older
- People who are 60 or older
- People with 2 or more certain medical conditions
- People who live or work in low income and affordable senior housing
- K-12 educators, K-12 school staff, and child care workers
- Certain workers

There are different ways to find a vaccine appointment if you're eligible:

- Preregister at [VaccineSignUp.mass.gov](https://vaccineSignUp.mass.gov) to be notified when it's your turn to schedule an appointment at one of **7 mass vaccination locations**: Fenway Park, Gillette Stadium, Reggie Lewis Center, DoubleTree Hotel in Danvers, Eastfield Mall in Springfield, Natick Mall and former Circuit City in Dartmouth.
- Use [VaxFinder.mass.gov](https://vaxfinder.mass.gov) to search for appointments at pharmacies, health care providers, and other community locations

Massachusetts' preregistration system makes it easier to request and schedule an appointment at one of the 7 mass vaccination locations. Eligible people can preregister for a COVID-19 vaccine appointment at mass vaccination locations only. More locations will be added to the system in April.

Once you sign up for preregistration, you'll receive weekly status updates. You can opt out at any time if you find an appointment elsewhere. Once an appointment is available, you'll be contacted with the opportunity to book the appointment and have 24 hours to accept it.

Massachusetts receives a limited supply of COVID-19 vaccine doses from the federal government each week. **Due to high demand and very limited supply, it may take several weeks to schedule an appointment or to be notified that an appointment is available at mass vaccination locations.**

Individuals 75 and older without access to the internet or who are unable to preregister or schedule their appointment online can call toll free [2-1-1](tel:2-1-1) or [\(877\) 211-6277](tel:877-211-6277) for assistance.

The most up to date and valuable information on vaccination is found at: <https://www.barnstablecountyhealth.org/vaccine-information>

PHASE IV, STEP 1 OF RE-OPENING (As of March 22, 2021)

COVID-19 Order No. 66 – Order Advancing All Communities to Phase IV, Step 1 of the Commonwealth’s Re-Opening Plan and Transitioning to a Travel Advisory Policy March 22nd, Appendix Adjusting Gathering Limits Set in COVID-19 Order No. 63.

The Baker-Polito Administration announced that Massachusetts will advance to Step 1 of Phase IV of the Commonwealth’s reopening plan on Monday, March 22. The Administration continues to take steps to reopen the Commonwealth’s economy with public health metrics continuing to trend in a positive direction. This includes drops in average daily COVID cases and hospitalizations. Massachusetts also continues to be a national leader in vaccination rates. The Administration also replaced the placed the Massachusetts Travel Order originally issued in July 2020 with a Travel Advisory, effective March 22.

In addition, the Administration also announced nearly \$31 million in awards to 710 additional small businesses in the tenth round of COVID-19 relief grants administered by the Massachusetts Growth Capital Corporation (MGCC).

Phase IV, Step 1 and Gathering Changes:

On March 1, Massachusetts loosened capacity restrictions for several industries and advanced to Step 2 of Phase III of the reopening plan. Since then, hospitalizations dropped by 20% and deaths dropped by 24%. The seven day average of new cases in long-term care facilities dropped by 53%. The positive test rate remains below 2% and has been for several weeks now. The seven day average of new cases is also down over this time by 7%.

Effective Monday, March 22, all communities in Massachusetts will move into Step 1 of Phase IV of the state’s reopening plan. This will open a range of previously closed business sectors under tight capacity restrictions that are expected to be adjusted over time if favorable trends in the public health data continue. Effective on the planned advancement to Step 1 of Phase IV, the following large capacity sports and entertainment venues will be permitted to operate at a strict 12% capacity limit after submitting a plan to the Department of Public Health (DPH):

- Indoor and outdoor stadiums
- Arenas
- Ballparks

Also effective on March 22, gathering limits for event venues and in public settings will increase to 100 people indoors and 150 people outdoors. Outdoor gatherings at private residences and in private backyards will remain at a maximum of 25 people, with indoor house gatherings remaining at 10 people.

Additionally, dance floors will be permitted at weddings and other events only, and overnight summer camps will be allowed to operate this coming summer. Exhibition and convention halls may also begin to operate, following gatherings limits and event protocols. Other Phase IV sectors must continue to remain closed.

Travel Order:

Effective Monday, March 22, the Massachusetts Travel Order will be replaced with a Travel Advisory.

The new travel advisory will urge all persons entering Massachusetts, including returning residents, are advised to quarantine for 10 days upon their arrival if they have been out of the state for 24 hours or more.

The advisory does not apply to anyone in the following categories:

- Anyone who is returning to Massachusetts after an absence of fewer than 24 hours.
- Travelers who have a negative COVID-19 test result that has been administered up to 72 hours prior to their arrival in Massachusetts.
- Workers who enter Massachusetts to perform critical infrastructure functions (as specified by the Federal Cybersecurity and Infrastructure Security Agency) while they are commuting to or from or while at work.
- Travelers who are fully vaccinated (i.e. who have received two doses of either the Moderna or Pfizer COVID-19 vaccines OR who have received a single dose of the Johnson & Johnson vaccine, 14 days or more ago and who do not have symptoms).

Travelers are additionally encouraged to consult and follow the CDC's guidelines and requirements for travel.

Highlights of Changes to the Sector-Specific Workplace Safety Standards for Phase IV, Step 1 <https://www.mass.gov/resource/reopening-sector-specific-protocols-and-best-practices>

- Theaters –removed Phase IV reference; the beverage stations will follow restaurant rules
- Restaurants – opens self-serve beverages
- Museums – increases walking tour size to 25
- Gyms and Fitness Centers – reduced distancing requirement from 14ft to 6ft
- Retail – reopens food courts, following restaurant rules (*reiterates most important rules, per HHS*)
- Events – Clarifies that the 90 min limit does not apply for seated food service at events, removes reference to travel order

Phase IV Enterprises that Must Remain Closed until Phase IV, Step 2

- Amusement parks, theme parks, indoor and outdoor waterparks and ball pits
- Street festivals and parades and agricultural festivals

- Road races and other large, outdoor organized amateur or professional group athletic events
- Bars, dance clubs and nightclubs
- Beer gardens, breweries, wineries and distillates not providing seated food service

TESTING

For testing options at Outer Cape Health, please call [508-905-2888](tel:508-905-2888) in advance to make a testing appointment.

Testing is available in other locations 7 days per week through Cape Cod Healthcare. Call the Community Testing Line at 508-534-7103 to make an appointment.

Katie O'Neill
Health Director

3/21/21: Barnstable County and Regional COVID-19 Daily Update

(N.B. I am no longer attempting to tally new probable cases alongside new confirmed cases. I have not received information on probable cases since 12/6/20, at which time Barnstable County had logged a total of 531.)

Good Morning All.

The towns of Barnstable and Yarmouth have returned to the highest risk (red) category in terms of average 2-week new case numbers.

The first case of the Brazilian variant P1 has been announced in Massachusetts in Barnstable County (30 year-old female). The contribution in Barnstable County to the new case numbers of any variants is unknown at this time.

In follow up to discussions between the relevant town health agents, the County, and the DPH, the DPH has stated that it will deploy additional testing resources to the mid-Cape region.

SUMMARY:

1. New Cases: DPH new cases reported yesterday:

Barnstable County: 98 new cases (cases continue to increase--mid-Cape sub-region)

Martha's Vineyard: 2 new cases

Nantucket: 0 new cases

2. Hospitalizations and Fatalities: 3-day avg. hospitalizations (now 23) has increased. 5 patients were in the ICU yesterday afternoon. There were 2 **COVID fatalities** reported Friday-Sunday. CCH and Falmouth Hospital have re-opened to limited visitation.

The first week of March marked the **one-year anniversary** of the recognition of the first COVID case in Massachusetts. In year 1 of this pandemic the **Barnstable County Case Fatality Rate (CFR) is 4%**, behind only Berkshire and Franklin Counties (which are also remote, rural locales), and is markedly higher than the **state CFR (2.8%)**.

Recent data on COVID fatalities in Barnstable County suggest that residents of **Long Term Care/Skilled Nursing Facilities/Rest Homes** represent **42.5%** of all fatalities (167 of 393 fatalities, as of 2/23/21). This is a **lower** percentage than that seen during phase 1 of the pandemic last spring (over 65%), and **this percentage continues to fall. Indeed, between 1/5/21 and 2/23/21 only 20% (28) of 137 fatalities occurred among LTC residents.**

3. Schools and Childcare Centers: Due to the mildness of the flu season the DPH has **removed the requirement** that all school children receive a flu vaccination on or

before 2/28/21. **School districts remain in a hybrid learning model.** However, **DESE Commissioner Jeffrey Riley has announced plans which will compel schools to return to 100% in-person learning, starting with elementary schools, in April.**

4. Testing; Test Positivity Rates (14-day, as of 3/17/21):

Barnstable County: 4.12% (vs. 3.22%) (**higher** vs. previous fortnight)

Dukes & Nantucket Counties: 2.32% (vs. 1.53%) (**higher**)

A test percent positivity rate below 5% suggests that an outbreak is on the way to **containment**.

5. Weekly Town Risk, and Statewide Cluster Analyses: See charts below (analysis of 3/11/21 data is pending).

6. Vaccination:

-Groups eligible for vaccination now are those in Phase 1, and Phase 2/Group 1 (persons aged 75+), and Phase 2/Group 2 (65+, 2+ comorbidities, residents and staff of low-income senior housing), and (effective 3/11) Phase 2/Group 3 --K-12 and early education/childcare teachers and staff, **depending upon availability of vaccine.**

-**Caregivers** (regardless of age) **accompanying a 75+ person to their vaccination appointment remain eligible for vaccination** and can receive vaccination under these circumstances at **DPH mass vaccination sites**. Local vaccination clinics may also allow this, but most are not doing so because of constrained vaccine supplies.

-Phase 2 of the State Vaccination Plan began on February 1. **On March 11th K-12 teachers and staff and childcare teachers and staff became eligible for vaccination.**

-Vaccination at local clinics during Phase 2 are by appointment only and **appointments are announced and able to be scheduled once County and local health authorities are sure of vaccine availability from the DPH.** The public is being given notice of planned vaccination clinics for eligible persons in Phase 2.

-Plans for 4-5 sub-regional mass vaccination sites on Cape Cod, for operation during Phase 2, are in place. **A Cape Cod Regional Vaccine Consortium** has been established via a partnership between the Barnstable County Health Dept, Local Town Boards of Health (LBOHs), Community Health Centers (CHCs), and Cape Cod Healthcare, and has received support from the DPH. The Consortium has established a **vaccination site at Cape Cod Community College** (which opened this week) and is also working with LBOHs and CHC to **organize in-reach to homebound persons** to vaccinate them. **The DPH is responsible for providing sufficient vaccine in order for the Consortium to reach its full potential.**

-**The DPH has begun reporting vaccination progress age group and by town.** Below is a summary table for Barnstable County by age group.

7. COVID Mutation and Changes in Transmissibility/Virulence/Other: There are four variants of concern: B117 (UK), B1351 (S. Africa), P1 (Brazil), and B1526 (New York City, which emerged in November). All four appear to be significantly more transmissible than the virus which dominated Wave 1 of the pandemic. Within two months of the B117 variant being identified in the UK (October) it became the dominant strain circulating there. The CDC is now posting surveillance information on the emergence of the B117 variant in the US: <https://www.cdc.gov/coronavirus/2019-ncov/transmission/variant-cases.html>. Existing vaccines may be less effective against these new strains. The degree to which this may be so is being investigated. Moderna and Pfizer are working on a booster shot to counter these new strains.

- B1526 now accounts for 40% of new cases in NYC
- B117 and B1351 have been identified in Massachusetts.

-The first case of the Brazilian variant P1 has been announced in Massachusetts in Barnstable County.

REPORT DETAIL:

1. New Cases

Daily new case numbers in Barnstable County are moving upward again, following a major decline since the holiday season surge new cases are moving upward again, due to **significant case increases in the towns of Barnstable and Yarmouth. 290 cases** were reported over the weekend (Friday to Sunday, inclusive), nearly 100 more than were reported over the prior weekend. The 7-day average new cases per 100,000 has increased to **37/100K**, with Barnstable County acquiring an **average of 78 cases per day over the past 7 days.**

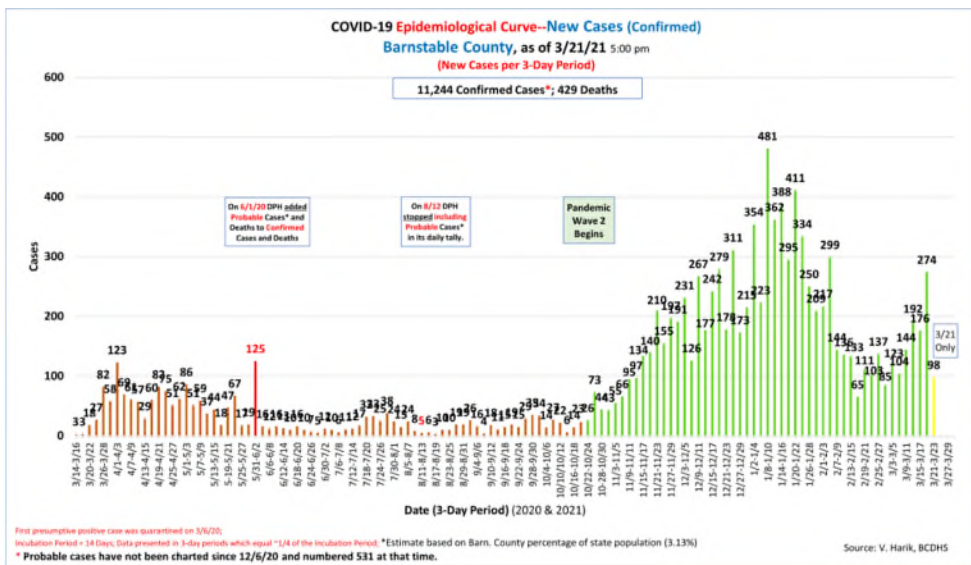

Nantucket's 7-day average cases per 100,000 population (now 24/100K) has dropped since last week. On average (7-day) Nantucket is now picking up **3** new cases per day. **9 cases** were reported over the weekend (Friday to Sunday, inclusive).

Martha's Vineyard's 7-day average cases per 100,000 population (12/100K) remains low but has increased. On average Dukes County is gaining approximately **2** new cases per day. **2 cases** were reported over the weekend (Friday to Sunday, inclusive).

Trailing 14-Day Testing and Cases by County:

In the context of adequate availability of testing and contact tracing, which our three counties appear to have achieved, **a test percent positivity rate below 5% suggests that an outbreak is on the way to containment.** Rates below 3% and 1% are further important containment milestones.

Test Positivity Rates (14-day, as of 3/17/21):

Barnstable County: 4.12% (vs. 3.22%) (**higher** vs. previous fortnight)

Dukes & Nantucket Counties: 2.32% (vs. 1.53%) (**higher**)

2. Hospitalizations and Fatalities

Hospitalizations and acuity of illness have decreased very significantly since the double peaks of the Wave 2 surge seen in mid-January and early February (corresponding Thanksgiving and Christmas holidays). Cape Cod Hospital and Falmouth Hospital have **resumed limited visitation** of inpatients.

Hospitalizations, Last Report:		Not Cumulative		Cumulative		3-Day Avg. of Persons in Hosp. (Med/Surg + ICU)	ICU Percent of Beds Occupied
		Hospital Beds Occupied (Last Report)	ICU Beds Occupied (Last Report)	Barnstable County Cases (Confirmed)	Barnstable County Deaths		
3/21/2021	Cape Cod Hospital	19	3				
	Falmouth Hospital	1	2				
		20	5	11,244	429	23.3	20%

Since DPH reporting of hospitalizations has a 2-day lag Tina Shaw of CCHC is providing me with more recent information (thank you Tina). Yesterday afternoon CCHC reported that there were **25 COVID patients in hospital, 5** of which were in the CCH ICU.

Fatalities: 2 fatalities were reported over the weekend. The total is **429**.

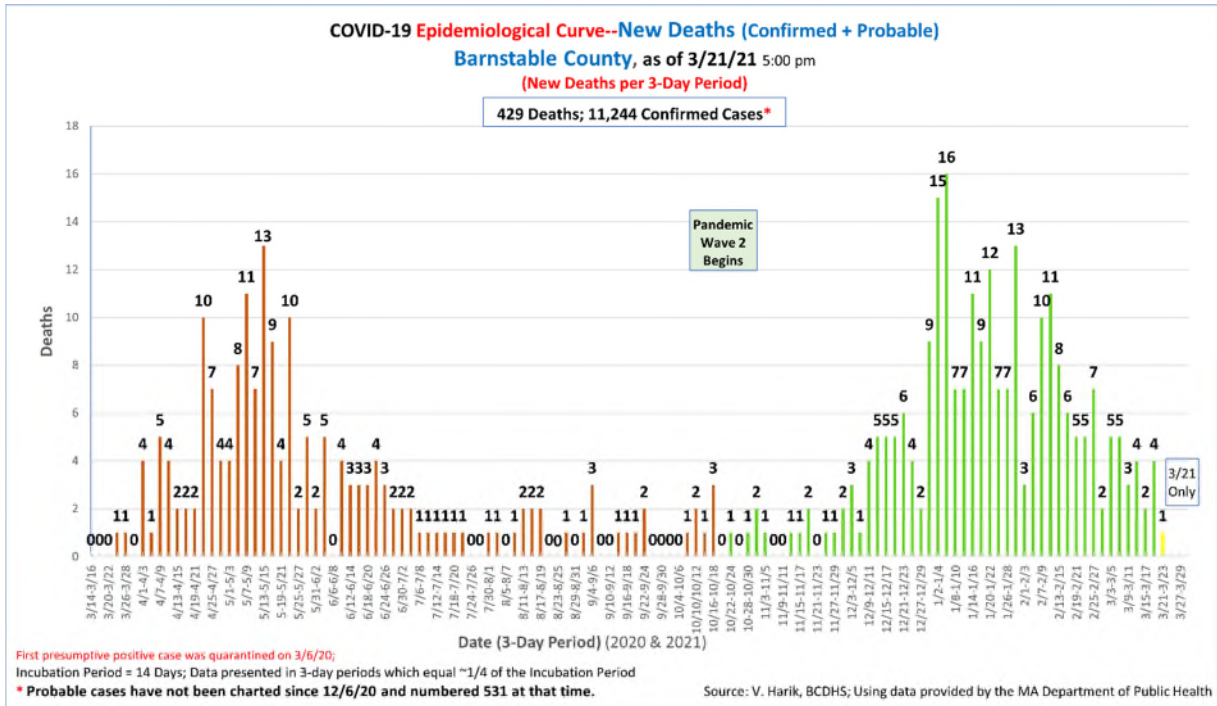

Recent data on COVID fatalities in Barnstable County suggest that residents of **Long Term Care/Skilled Nursing Facilities/Rest Homes** represent **42.5%** of all fatalities (167 of 393 fatalities, as of 2/25/21). This is a **lower** percentage than that seen during phase 1 of the pandemic last spring (over 65%), and **this percentage continues to fall. Indeed, between 1/5/21 and 2/23/21 only 20% of the County's 137 fatalities occurred among LTC residents.**

This month marks the one-year **anniversary** of the recognition of the first COVID case in Massachusetts. In year 1 of this pandemic the **Barnstable County Case Fatality Rate (CFR) is 4%**, behind only Berkshire and Franklin Counties (which are also remote, rural locales), and is markedly higher than **the state CFR (2.8%).**

3. Schools and Childcare Centers

School districts are staying vigilant and reacting well to new cases. School districts on the Cape and Islands are in a hybrid learning status, **however DESE Commissioner Jeffrey Riley has announced plans which will compel schools to return to 100% in-person learning, starting with elementary schools, in April. As such (and noted elsewhere), school and childcare teachers and staff became eligible for vaccinations on 3/11.**

DESE and the DPH (memo of 1/8/21) announced that they are seeking to introduce COVID-19 screening testing using a pooled strategy in the school setting. Schools may elect to participate by responding to a survey that DESE/DPH have posted. The status of this initiative is unclear at this time.

~~For the 2020-2021 school year the DPH has mandated that all school children be vaccinated for seasonal influenza. This week the DPH extended the deadline for doing so from 12/31/20 to 2/28/21. This mandate has been canceled by the DPH.~~

4. Testing

Additional testing locations in Barnstable County for both symptomatic and asymptomatic persons remain open in **Falmouth** at the Fairgrounds and in **Hyannis** at Cape Cod Hospital (the Melody Tent site has been given over to vaccination clinics). Daily testing capacity is 50 at the Falmouth site and 350 at the Hyannis site. Neither site is open daily and persons must call ahead for an appointment. Details: <https://www.capecodhealth.org/medical-services/infectious-disease/coronavirus/covid-19-testing-process/>.

In late December additional testing by **Outer Cape Community Health Services** began and continues at its 3 locations in Wellfleet, Harwich Port, and Provincetown (<https://outercape.org/2020/12/23/outer-cape-health-services-to-offer-covid-19-asymptomatic-testing-beginning-december-23/>). The **Community Health Center of Cape Cod** is also offering testing at its locations. These sites may not open be daily and persons must call ahead for an appointment.

Eligibility criteria for the testing include residency in Barnstable County. Testing is done by appointment only. Tests cost \$75, \$110 for travel-related tests, and no one will be turned away if unable to pay for a test.

DPH-mandated **routine testing** in skilled nursing facilities/long term care settings (SNF/LTC) continues. This provides critical surveillance and allows these facilities to stay ahead of asymptomatic spread amongst staff and residents. Routine testing in SNF/LTC settings is conducted weekly for staff.

In addition, the State's **BinaxNOW rapid testing program** (available to **schools**) has been extended to visitors of **nursing homes** and rest home residents (LTC settings) to allow visitation of residents while limiting the risk of infection from visitors. DPH has published guidance on this. The program has also been extended to **homeless shelters** and management of these facilities may apply to the EEC and DPH for testing kits.

5. Weekly Town Risk and Statewide Cluster Analyses

MA DPH Data Dashboard, WEEKLY REPORT of 3/18/21 (for the Period 2/28/21 to 3/13/21)										
City/Town	Population	(March 2020 to Present) Total Case Count	Case Count Last 14 Days	Average Daily Incidence Rate per 100K	Relative Change in Case Count	(March 2020 to Present) Total Tests	Total Tests Last 14 Days	Positive Tests Last 14 Days	Percent Positivity Last 14 Days	Change in Percent Positivity
Barnstable	44,773	3,283	283	45.1	Higher	64,532	3,954	296	7.49%	Higher
Bourne	21,026	1,077	44	14.9	Lower	37,211	2,395	56	2.34%	No Change
Brewster	9,926	392	16	11.5	Higher	16,134	799	16	2.00%	Higher
Chatham	5,830	276	16	19.6	No Change	8,042	365	17	4.66%	Higher
Dennis	13,088	601	31	16.9	Higher	16,939	899	32	3.56%	Higher
Eastham	4,603	134	12	18.6	Lower	4,522	261	14	5.36%	Lower
Falmouth	31,190	1,245	50	11.5	Lower	53,504	2,801	60	2.14%	Lower
Harwich	12,589	606	23	13.1	Higher	16,828	850	26	3.06%	Higher
Mashpee	15,535	666	32	14.7	No Change	22,118	1,344	41	3.05%	Higher
Orleans	5,620	260	13	16.5	Higher	6,483	368	15	4.08%	Higher
Provincetown	2,583	69	7	19.4	Higher	4,484	223	8	3.59%	Higher
Sandwich	21,078	945	47	15.9	Lower	26,352	1,691	54	3.19%	Lower
Truro	1,968	39	1	3.6	Higher	1,965	111	1	0.90%	Higher
Wellfleet	2,760	61	5	12.9	Higher	2,895	199	6	3.02%	Higher
Yarmouth	24,062	1,218	89	26.4	Higher	34,340	1,615	95	5.88%	Higher
Barnstable County	216,629	10,872	669	22.1	Higher	316,349	17,875	737	4.12%	Higher
Aquinnah	261	1	0	0	No Change	517	10	0	0%	No Change
Chilmark	759	16	1	9.4	Lower	3,543	139	1	0.72%	Lower
Edgartown	4,086	264	3	5.2	Lower	11,306	552	3	0.54%	Lower
Gosnold	45	5	0	0	No Change	127	2	0	0%	No Change
Oak Bluffs	5,209	236	7	9.6	Lower	7,656	334	9	2.69%	Higher
Tisbury	4,174	265	5	8.6	Lower	14,238	616	5	0.81%	Lower
West Tisbury	2,871	94	1	2.5	Lower	5,051	227	1	0.44%	Lower
Dukes County	17,404	886	18	7.0	Lower	42,438	1,880	19	1.01%	Lower
Nantucket	11,416	1,221	58	36.3	Higher	24,494	1,485	59	3.97%	Higher
Dukes and Nantucket Counties	28,820	2,105	75	18.6	Higher	66,932	3,365	78	2.32%	Higher
State	6,964,383	572,278	19,036	19.5	Lower	17,607,605	1,193,281	21,789	1.83%	No Change
Data Source: MA DPH, 3/18/21 Weekly COVID Report (https://www.mass.gov/info-details/covid-19-response-reporting); Analysis: V. Harik BCDHS.										
Massachusetts COVID Testing Rates, As Applied to Barnstable County (Thru 3/13/21)										
Sources: Census.gov; MA DPH Weekly COVID Report, 3/18/21. Analysis: V. Harik, BCDHS										
					MA				Barnstable County	
Population Estimate (via DPH)					6,964,383				216,629	
									Barnstable County % of MA Pop.	3.11%
									Barn. County % of Total MA Tests	1.80%
									Barn. County % of MA Tests, Past Two Weeks	1.50%
									Barn. County % of MA Total Confirmed Cases	1.90%
									Barn. County % of MA Confirmed Cases, Past Two Weeks	3.51%
									MA % Positive Tests Last 14 Days	1.83%
									Barnstable County % Positive Tests Last 14 Days	4.12%

Active COVID Clusters by Exposure Setting Type for the Period 2/14/21 to 3/13/21 (as of 3/18/21)
 Source: <https://www.mass.gov/info-details/covid-19-response-reporting>. Tabulation: V. Harik, Barnstable County DHS
 Sorted by Number of Cases in New Cluster Settings

	Exposure Setting	New Clusters (Identified 2/14/21 – 3/13/21)			Ongoing Clusters (Cluster Identified Prior to 2/14/21 But Not Meeting Criteria for Closing)			Total		
		Clusters	Confirmed Cases	Close Contacts	Clusters	Confirmed Cases	Close Contacts	Clusters	Confirmed Cases	Close Contacts
1	Household	6,148	15,670	0	17,174	2,426	0	23,322	18,096	0
2	Child Care	72	245	240	219	162	162	291	407	402
3	Colleges & Universities	31	224	89	59	65	51	90	289	140
4	Long Term Care Facilities	25	91	0	121	248	0	146	339	0
5	K-12 Schools	15	74	82	36	3	45	51	77	127
6	Organized Athletics/Camps	14	66	174	59	14	85	73	80	259
7	Restaurants & Food Courts	15	63	21	27	8	4	42	71	25
8	Industrial Settings	11	57	6	41	54	55	52	111	61
9	Social Gatherings	9	52	39	13	7	13	22	59	52
10	Retail & Services	9	40	2	42	25	8	51	65	10

6. Vaccination

Groups eligible for vaccination now are those in Phase 1, Phase 2/Group 1 (persons aged 75+), and Phase 2/Group 2 (65+, 2+ comorbidities, and residents and staff of low-income senior housing) depending upon availability of vaccine.

Caregivers (regardless of age) **accompanying a 75+ person to their vaccination appointment** remain eligible for vaccination and can receive vaccination under these circumstances at DPH mass vaccination sites. Local vaccination clinics may also allow this, but most are not doing so because of constrained vaccine supplies.

-Phase 2 of the State Vaccination Plan began on February 1. **On March 11th K-12 teachers and staff and childcare teachers and staff became eligible for vaccination.**

The DPH has released the timeline by which all remaining groups will become eligible for vaccination:

Timeline for remaining groups:

March 22nd : Residents 60+ and certain workers (see <https://www.mass.gov/info-details/covid-19-vaccinations-for-certain-workers>)

April 5th : Residents 55+ and residents with one certain medical condition

April 19th: General public ages 16 years of age and older

3/19/21: Barnstable County and Regional COVID-19 Daily Update

(N.B. I am no longer attempting to tally new probable cases alongside new confirmed cases. I have not received information on probable cases since 12/6/20, at which time Barnstable County had logged a total of 531.)

Good Morning All.

MA Vaccination Eligibility Timeline for all remaining groups has been released: The DPH has released the timeline by which all remaining groups will become eligible for vaccination:

Timeline for remaining groups:

March 22nd : Residents 60+ and certain workers (see <https://www.mass.gov/info-details/covid-19-vaccinations-for-certain-workers>, and the table below)

April 5th : Residents 55+ and residents with one certain medical condition

April 19th: General public ages 16 years of age and older

Group	Eligibility Start Date
Residents 60+ and certain workers	March 22nd
Residents 55+ and residents with one certain medical condition	April 5th
General public ages 16 years of age and older	April 19th

The first case of the Brazilian variant P1 has been announced in Massachusetts in Barnstable County (30 year-old female).

SUMMARY:

1. New Cases: DPH new cases reported yesterday:

Barnstable County: 82 new cases (cases continue climb--mid-Cape sub-region)

Martha's Vineyard: 5 new cases

Nantucket: 3 new cases (cases continue to climb)

2. Hospitalizations and Fatalities: 3-day avg. hospitalizations (now 19) remain in the 'teens (they were in the mid-60s in January during the post-holiday surge). ICU patient numbers have been stable, between 2 to 5 patients per day (in CCH). There were 3 COVID fatalities reported yesterday. CCH and Falmouth Hospital have re-opened to limited visitation.

The first week of March marked the **one-year anniversary** of the recognition of the first COVID case in Massachusetts. In year 1 of this pandemic the **Barnstable County Case Fatality Rate (CFR) is 4%**, behind only Berkshire and Franklin Counties (which are also remote, rural locales), and is markedly higher than the **state CFR (2.8%)**.

Recent data on COVID fatalities in Barnstable County suggest that residents of **Long Term Care/Skilled Nursing Facilities/Rest Homes** represent **42.5%** of all fatalities (167 of 393 fatalities, as of 2/23/21). This is a **lower** percentage than that seen during phase 1 of the pandemic last spring (over 65%), and **this percentage continues to fall. Indeed, between 1/5/21 and 2/23/21 only 20% (28) of 137 fatalities occurred among LTC residents.**

3. Schools and Childcare Centers: Due to the mildness of the flu season the DPH has **removed the requirement** that all school children receive a flu vaccination on or before 2/28/21. **School districts remain in a hybrid learning model.** However, **DESE Commissioner Jeffrey Riley has announced plans which will compel schools to return to 100% in-person learning, starting with elementary schools, in April.**

4. Testing; Test Positivity Rates (14-day, as of 3/17/21):

Barnstable County: 4.12% (vs. 3.22%) (**higher** vs. previous fortnight)

Dukes & Nantucket Counties: 2.32% (vs. 1.53%) (**higher**)

A test percent positivity rate below 5% suggests that an outbreak is on the way to **containment**.

5. Weekly Town Risk, and Statewide Cluster Analyses: See charts below (analysis of 3/11/21 data is pending).

6. Vaccination:

-Groups eligible for vaccination now are those in Phase 1, and Phase 2/Group 1 (persons aged 75+), and Phase 2/Group 2 (65+, 2+ comorbidities, residents and staff of low-income senior housing), and (effective 3/11) Phase 2/Group 3 --K-12 and early education/childcare teachers and staff, **depending upon availability of vaccine.**

-Caregivers (regardless of age) accompanying a 75+ person to their vaccination appointment remain eligible for vaccination and can receive vaccination under these circumstances at **DPH mass vaccination sites**. Local vaccination clinics may also allow this, but most are not doing so because of constrained vaccine supplies.

-Phase 2 of the State Vaccination Plan began on February 1. **On March 11th K-12 teachers and staff and childcare teachers and staff became eligible for vaccination.**

-Vaccination at local clinics during Phase 2 are by appointment only and **appointments are announced and able to be scheduled once County and local health authorities are sure of vaccine availability from the DPH**. The public is being given notice of planned vaccination clinics for eligible persons in Phase 2.

-Plans for 4-5 sub-regional mass vaccination sites on Cape Cod, for operation during Phase 2, are in place. **A Cape Cod Regional Vaccine Consortium** has been established via a partnership between the Barnstable County Health Dept, Local Town Boards of Health (LBOHs), Community Health Centers (CHCs), and Cape Cod Healthcare, and has received support from the DPH. The Consortium has established a **vaccination site at Cape Cod Community College** (which opened this week) and is also working with LBOHs and CHC to **organize in-reach to homebound persons** to vaccinate them. **The DPH is responsible for providing sufficient vaccine in order for the Consortium to reach its full potential.**

-**The DPH has begun reporting vaccination progress age group and by town.** Below is a summary table for Barnstable County by age group.

7. COVID Mutation and Changes in Transmissibility/Virulence/Other: **There are four variants of concern: B117 (UK), B1351 (S. Africa), P1 (Brazil), and B1526 (New York City, which emerged in November)**. All four appear to be significantly more transmissible than the virus which dominated Wave 1 of the pandemic. Within two months of the B117 variant being identified in the UK (October) it became the dominant strain circulating there. The CDC is now posting surveillance information on the emergence of the B117 variant in the US: <https://www.cdc.gov/coronavirus/2019-ncov/transmission/variant-cases.html>. Existing vaccines may be less effective against these new strains. The degree to which this may be so is being investigated. Moderna and Pfizer are working on a booster shot to counter these new strains.

-B1526 now accounts for 40% of new cases in NYC

-**B117 and B1351 have been identified in Massachusetts.**

-**The first case of the Brazilian variant P1 has been announced in Massachusetts in Barnstable County.**

REPORT DETAIL:

1. New Cases

Daily new case numbers in Barnstable County are moving upward again, following a major decline since the holiday season surge. **192 cases** were reported over the weekend (Friday to Sunday, inclusive), a further 176 cases were reported Monday-Wednesday, and 82 cases were reported yesterday. **The case increases are most prominent in the mid-Cape region.** The 7-day average new cases per 100,000 has increased to **30/100K**, with Barnstable County acquiring an **average of 64 cases per day over the past 7 days.**

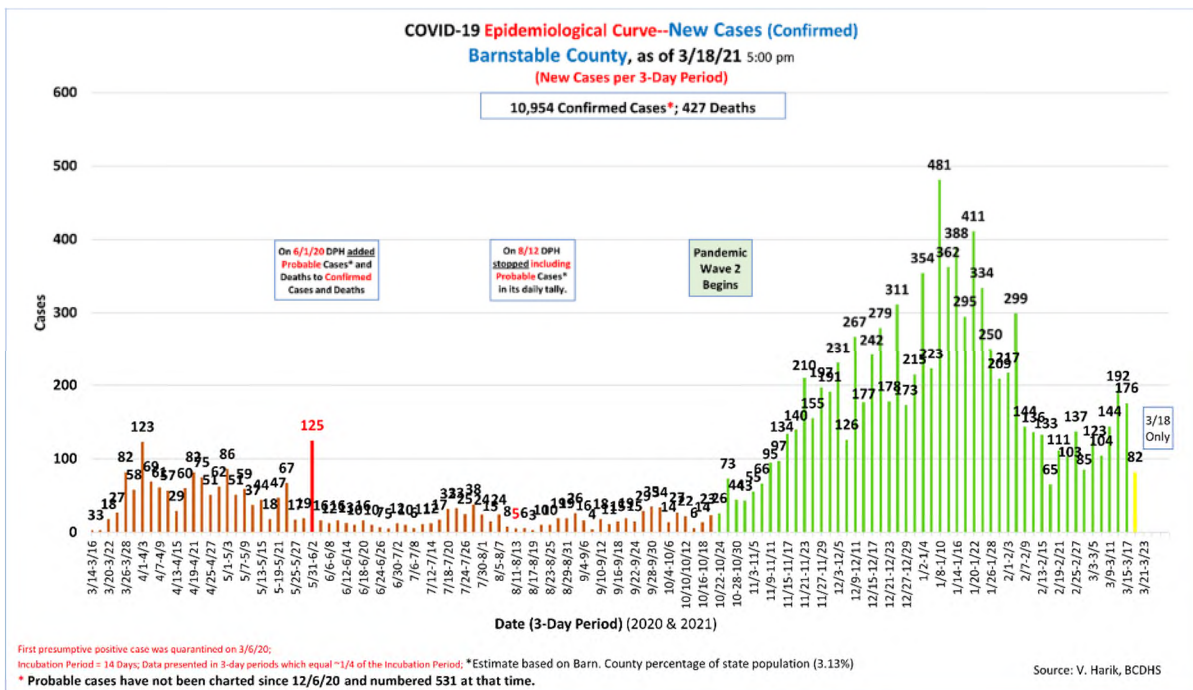

Nantucket's 7-day average cases per 100,000 population (now 45/100K) remains high. On average (7-day) Nantucket is now picking up 5 new cases per day. 26 cases were reported over the weekend (Friday to Sunday, inclusive), 7 new cases were reported yesterday.

Martha's Vineyard's 7-day average cases per 100,000 population (4/100K) remains very low. On average Dukes County is gaining approximately 1.4 new cases per day. 5 cases were reported yesterday.

Trailing 14-Day Testing and Cases by County:

In the context of adequate availability of testing and contact tracing, which our three counties appear to have achieved, a test percent positivity rate below 5% suggests that

an outbreak is on the way to containment. Rates below 3% and 1% are further important containment milestones.

Test Positivity Rates (14-day, as of 3/17/21):

Barnstable County: 4.12% (vs. 3.22%) (**higher** vs. previous fortnight)

Dukes & Nantucket Counties: 2.32% (vs. 1.53%) (**higher**)

2. Hospitalizations and Fatalities

Hospitalizations and acuity of illness have decreased very significantly since the double peaks of the Wave 2 surge seen in mid-January and early February (corresponding Thanksgiving and Christmas holidays). Cape Cod Hospital and Falmouth Hospital have **resumed limited visitation** of inpatients.

Hospitalizations, Last Report:		Not Cumulative		Cumulative			
		Hospital Beds Occupied (Last Report)	ICU Beds Occupied (Last Report)	Barnstable County Cases (Confirmed)	Barnstable County Deaths	3-Day Avg. of Persons in Hosp. (Med/Surg + ICU)	ICU Percent of Beds Occupied
3/18/2021	Cape Cod Hospital	12	3				
	Falmouth Hospital	2	1				
		14	4	10,954	427	19.3	22%

Since DPH reporting of hospitalizations has a 2-day lag Tina Shaw of CCHC is providing me with more recent information (thank you Tina). Yesterday afternoon CCHC reported that there were **18 COVID patients in hospital, 4** of which were in the CCH ICU.

Fatalities: 3 fatalities were reported yesterday. The total is **427**.

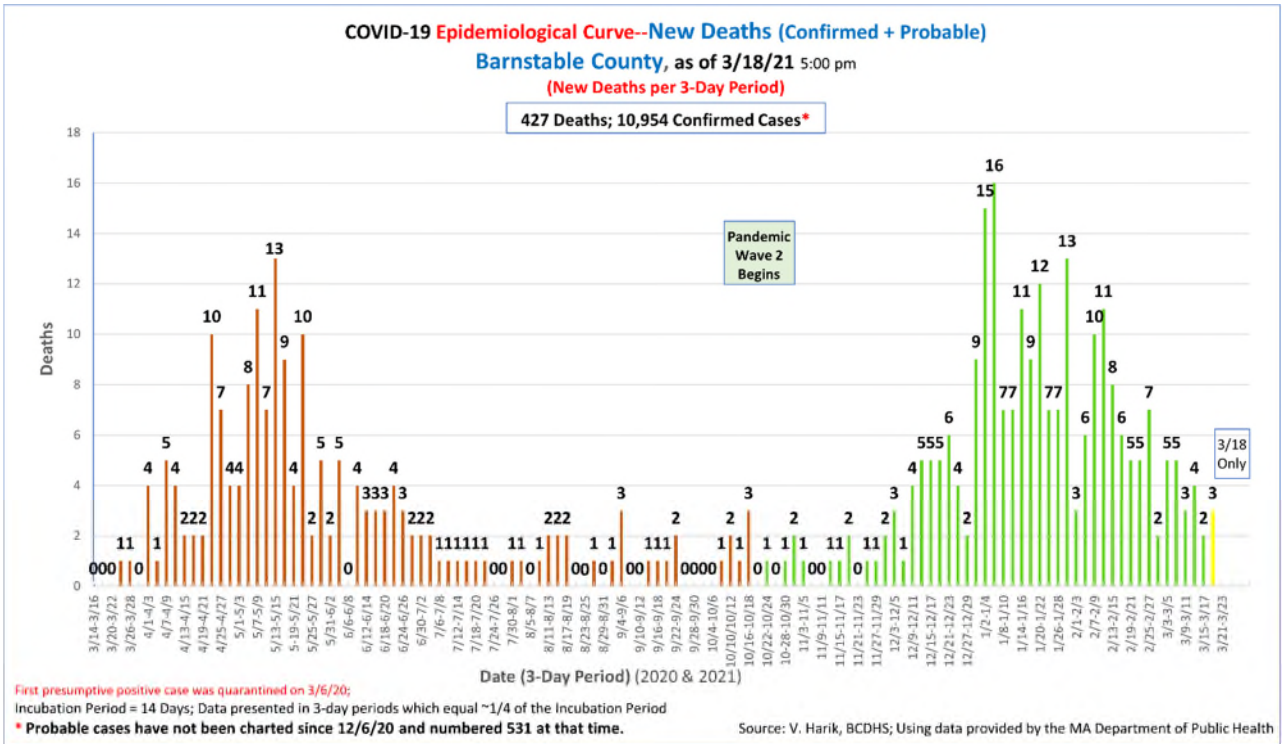

Recent data on COVID fatalities in Barnstable County suggest that residents of **Long Term Care/Skilled Nursing Facilities/Rest Homes** represent **42.5%** of all fatalities (167 of 393 fatalities, as of 2/25/21). This is a **lower** percentage than that seen during phase 1 of the pandemic last spring (over 65%), and **this percentage continues to fall. Indeed, between 1/5/21 and 2/23/21 only 20% of the County's 137 fatalities occurred among LTC residents.**

This month marks the one-year **anniversary** of the recognition of the first COVID case in Massachusetts. In year 1 of this pandemic the **Barnstable County Case Fatality Rate (CFR) is 4%**, behind only Berkshire and Franklin Counties (which are also remote, rural locales), and is markedly higher than **the state CFR (2.8%).**

3. Schools and Childcare Centers

School districts are staying vigilant and reacting well to new cases. School districts on the Cape and Islands are in a hybrid learning status, **however DESE Commissioner Jeffrey Riley has announced plans which will compel schools to return to 100% in-person learning, starting with elementary schools, in April. As such (and noted elsewhere), school and childcare teachers and staff became eligible for vaccinations last week (3/11).**

DESE and the DPH (memo of 1/8/21) announced that they are seeking to introduce COVID-19 screening testing using a pooled strategy in the school setting. Schools may

elect to participate by responding to a survey that DESE/DPH have posted. The status of this initiative is unclear at this time.

~~For the 2020-2021 school year the DPH has mandated that all school children be vaccinated for seasonal influenza. This week the DPH extended the deadline for doing so from 12/31/20 to 2/28/21. This mandate has been canceled by the DPH.~~

4. Testing

Additional testing locations in Barnstable County for both symptomatic and asymptomatic persons remain open in **Falmouth** at the Fairgrounds and in **Hyannis** at Cape Cod Hospital (the Melody Tent site has been given over to vaccination clinics). Daily testing capacity is 50 at the Falmouth site and 350 at the Hyannis site. Neither site is open daily and persons must call ahead for an appointment. Details: <https://www.capecodhealth.org/medical-services/infectious-disease/coronavirus/covid-19-testing-process/>.

In late December additional testing by **Outer Cape Community Health Services** began and continues at its 3 locations in Wellfleet, Harwich Port, and Provincetown (<https://outercape.org/2020/12/23/outer-cape-health-services-to-offer-covid-19-asymptomatic-testing-beginning-december-23/>). The **Community Health Center of Cape Cod** is also offering testing at its locations. These sites may not open daily and persons must call ahead for an appointment.

Eligibility criteria for the testing include residency in Barnstable County. Testing is done by appointment only. Tests cost \$75, \$110 for travel-related tests, and no one will be turned away if unable to pay for a test.

DPH-mandated **routine testing** in skilled nursing facilities/long term care settings (SNF/LTC) continues. This provides critical surveillance and allows these facilities to stay ahead of asymptomatic spread amongst staff and residents. Routine testing in SNF/LTC settings is conducted weekly for staff.

In addition, the State's **BinaxNOW rapid testing program** (available to **schools**) has been extended to visitors of **nursing homes** and rest home residents (LTC settings) to allow visitation of residents while limiting the risk of infection from visitors. DPH has published guidance on this. The program has also been extended to **childcare centers** (? Checking...) and **homeless shelters** and management of these facilities may apply to the EEC and DPH for testing kits.

5. Weekly Town Risk and Statewide Cluster Analyses (3/17/21 Update in process)

MA DPH Data Dashboard, WEEKLY REPORT of 3/11/21 (for the Period 2/21/21 to 3/6/21)										
City/Town	Population	(March 2020 to Present) Total Case Count	Case Count Last 14 Days	Average Daily Incidence Rate per 100K	Relative Change in Case Count	(March 2020 to Present) Total Tests	Total Tests Last 14 Days	Positive Tests Last 14 Days	Percent Positivity Last 14 Days	Change in Percent Positivity
Barnstable	44,773	3,094	180	28.7	Higher	62,392	3,868	193	4.99%	Higher
Bourne	21,026	1,052	50	17.0	Lower	36,039	2,519	60	2.38%	Lower
Brewster	9,926	386	14	10.1	Higher	15,818	886	15	1.69%	Higher
Chatham	5,830	272	16	19.6	Higher	7,873	398	16	4.02%	Higher
Dennis	13,088	575	15	8.2	Lower	16,485	987	19	1.93%	Lower
Eastham	4,603	129	13	20.2	Lower	4,397	301	17	5.65%	Lower
Falmouth	31,190	1,222	56	12.8	Lower	52,069	2,824	65	2.30%	Lower
Harwich	12,589	587	12	6.8	Lower	16,387	911	15	1.65%	Lower
Mashpee	15,535	639	32	14.7	Lower	21,373	1,222	35	2.86%	Higher
Orleans	5,620	251	9	11.4	Lower	6,298	403	10	2.48%	Lower
Provincetown	2,583	65	5	13.8	Higher	4,341	256	7	2.73%	Higher
Sandwich	21,078	919	64	21.7	Higher	25,596	1,887	69	3.66%	Lower
Truro	1,968	38	0	0	Higher	1,892	100	0	0%	Lower
Wellfleet	2,760	59	3	7.8	Higher	2,785	172	4	2.33%	Higher
Yarmouth	24,062	1,164	60	17.8	Higher	33,512	1,670	67	4.01%	Higher
Barnstable County	216,629	10,452	529	17.4	Higher	307,257	18,404	592	3.22%	Higher
Aquinnah	261	0	0	0	No Change	513	14	0	0%	No Change
Chilmark	759	16	1	18.8	Higher	3,479	176	2	1.14%	Higher
Edgartown	4,086	264	8	14.0	No Change	11,081	632	9	1.42%	Lower
Gosnold	45	5	0	0	No Change	126	1	0	0%	No Change
Oak Bluffs	5,209	232	7	9.6	No Change	7488	419	7	1.67%	No Change
Tisbury	4,174	264	8	13.7	No Change	13,970	745	8	1.07%	No Change
West Tisbury	2,871	94	0	10.0	Lower	4,969	297	4	1.35%	Lower
Dukes County	17,404	880	25	11.9	No Change	41,626	2,284	30	1.31%	Lower
Nantucket	11,416	1,187	30	18.8	Higher	23,828	1,700	31	1.82%	Higher
Dukes and Nantucket Counties	28,820	2,066	59	14.6	Higher	65,454	3,984	61	1.53%	Higher
State	6,964,383	562,394	19,791	20.3	Lower	17,019,491	1,245,674	22,843	1.83%	Lower

Data Source: MA DPH, 3/11/21 Weekly COVID Report (<https://www.mass.gov/info-details/covid-19-response-reporting>); Analysis: V. Harik BCDHS.

Active COVID Clusters by Exposure Setting Type for the Period 2/7/21 to 3/6/21 (as of 3/11/21)										
Source: https://www.mass.gov/info-details/covid-19-response-reporting . Tabulation: V. Harik, Barnstable County DHS										
Sorted by Number of Cases in New Cluster Settings										
	Exposure Setting	New Clusters (Identified 2/7/21 – 3/6/21)			Ongoing Clusters (Cluster Identified Prior to 2/7/21 But Not Meeting Criteria for Closing)			Total		
		Clusters	Confirmed Cases	Close Contacts	Clusters	Confirmed Cases	Close Contacts	Clusters	Confirmed Cases	Close Contacts
1	Household	6,311	16,149	---	21,753	3,172	---	28,064	19,321	---
2	Child Care	64	268	213	244	114	211	308	382	424
3	Colleges & Universities	37	257	86	50	82	30	87	339	116
4	Organized Athletics/Camps	20	97	253	59	19	111	79	116	364
5	Long Term Care Facilities	22	93	---	136	351	---	158	444	---
6	Industrial Settings	14	82	38	39	51	26	53	133	64
7	Social Gatherings	7	51	16	21	11	14	28	62	30
8	Retail & Services	10	48	7	46	35	16	56	83	23
9	K-12 Schools	8	41	53	42	13	43	50	54	96
10	Restaurants & Food Courts	10	36	11	33	11	5	43	47	16

6. Vaccination

Groups eligible for vaccination now are those in Phase 1, Phase 2/Group 1 (persons aged 75+), and Phase 2/Group 2 (65+, 2+ comorbidities, and residents and staff of low-income senior housing) depending upon availability of vaccine.

Caregivers (regardless of age) **accompanying a 75+ person to their vaccination appointment** remain eligible for vaccination and can receive vaccination under these circumstances at DPH mass vaccination sites. Local vaccination clinics may also allow this, but most are not doing so because of constrained vaccine supplies.

-Phase 2 of the State Vaccination Plan began on February 1. **On March 11th K-12 teachers and staff and childcare teachers and staff became eligible for vaccination.**

The DPH has released the timeline by which all remaining groups will become eligible for vaccination:

Timeline for remaining groups:

March 22nd : Residents 60+ and certain workers (see <https://www.mass.gov/info-details/covid-19-vaccinations-for-certain-workers>)

April 5th : Residents 55+ and residents with one certain medical condition

April 19th: General public ages 16 years of age and older

The following workers become eligible for vaccination on March 22, 2021:	
Worker category	Definition / examples (if applicable)
Restaurant or cafe workers	Cooks, servers, maintenance staff, managers, cashiers
Food, meatpacking, beverage, agriculture, consumer goods, retail, or food service workers	All staff involved in the production, processing, storage, transport, wholesale and retail sale, preparation, and service of food and consumer goods, including farm and other agricultural workers, including farm stand and nurseries
Grocery and convenience store workers	Cashiers, baggers, stockers, managers, maintenance staff, security staff
Food pantry workers or volunteers	
Medical supply chain workers	Workers directly involved in the manufacturing and production, packaging, transport, quality control, and sale of materials critical to the delivery of medical care
Vaccine development workers	Workers directly involved in research, development, manufacturing and production, packaging, transport, quality control, and sale of vaccines (COVID-19 and others)
Transit/transportation workers	Drivers/operators, attendants, sales, administrators, maintenance staff, public and private bus, train/subway, passenger boat/ferries, passenger air, and automobile (including rental car, car service/limousine, taxi, and ride apps) transportation, bridge and road construction and maintenance workers, shipping port and terminal workers, commercial transportation
Public works, water, wastewater, or utility workers	Utility: Electrical generation and supply system, natural gas delivery, nuclear power plant, water supply, telephone, cable/fiber optical/broadband/cellular service workers Public works including street repair, street lighting, public park, beach, and trail maintenance workers.
Sanitation workers	Drivers, solid waste handlers, recycling staff, street cleaners, sewer and storm water system workers
Public health workers	Public-facing federal, state, and local governmental public health workers
Court system worker (judges, prosecutors, defense attorneys, clerks), other than court officers who are listed under first responders	Criminal court workers, including judges, prosecutors, public defenders, private defense attorneys, clerks, maintenance workers
Funeral directors and funeral workers	Funeral directors/morticians, other funeral workers (funeral home staff, drivers, maintenance workers, cemetery workers, funeral cosmetology workers)

Vaccination at local clinics during Phase 2 is by appointment only and **appointments are announced and able to be scheduled once County and local health authorities are sure of vaccine availability from the DPH.** The public is being given notice of planned vaccination clinics for eligible persons in Phase 2.

Appointments (<https://www.cic-health.com/vaccines-location>) may not be immediately available due to overwhelming demand and still-limited supply of vaccine from the manufacturers. **Appointments for local vaccination clinics are only being scheduled once County and local health authorities can be sure of vaccine availability from the DPH.** The public is being given notice of planned vaccination clinics for eligible persons in Phase 2.

Vaccination is available at several **State-run mass vaccination sites** around Massachusetts. The closest ones to Cape Cod are at **Gillette Stadium in Foxboro and in Dartmouth.** Appointments can be scheduled by visiting <https://www.cic-health.com/vaccines-location>, or calling **2-1-1** and following the prompts if the citizen does not have access to/or cannot operate on the internet.

-Plans for 4-5 sub-regional mass vaccination sites on Cape Cod, for operation during Phase 2, are in place. A **Cape Cod Regional Vaccine Consortium** has been established via a partnership between the Barnstable County Health Dept, Local Town Boards of Health (LBOHs), Community Health Centers (CHCs), and Cape Cod Healthcare, and has received support from the DPH. The Consortium has established a **vaccination site at Cape Cod Community College** and is also working with LBOHs and CHC to **organize in-reach to homebound persons** to vaccinate them. **The DPH is responsible for providing sufficient vaccine in order for the Consortium to reach its full potential.**

Harbor Health Services, Inc. (Hyannis) will join the other three Federally Qualified Community Health Centers on Cape Cod in offering **vaccination clinics.**

The State has contracted with **CVS and Walgreens** to arrange vaccination of **older adults in SNFs/congregate care.** **CVS, Walgreens, and Stop & Shop pharmacies** are also scheduling vaccinations for the groups in Phase 2, again depending upon vaccine supply.

The DPH has begun reporting vaccination progress age group and by town. Below is a summary for Barnstable County by age group **(3/17 update in process)**

Massachusetts Department of Public Health COVID-19 Dashboard – Thursday, March 11, 2021										
Individuals with at Least One Dose Administered by County and Age Group, as of 3/9/21										
Source: Data, MA DPH; Analysis, V. Harik, Barnstable County Dept. of Human Services										
Barnstable County	0-19 Years	20-29 Years	30-39 Years	40-49 Years	50-59 Years	60-64 Years	65-69 Years	70-74 Years	75+ Years	Total
Total Population by Age Bracket	36,252	22,041	18,884	19,841	31,497	20,219	20,609	18,355	28,931	216,629
Age Bracket % of County Pop.	17%	10%	9%	9%	15%	9%	10%	8%	13%	
Persons in Age Group with at Least One Dose	96	2,204	3,210	3,968	6,929	5,055	10,511	10,462	23,434	65,870
Percent of Age Group with at Least One Dose	0.26%	10%	17%	20%	22%	25%	51%	57%	81%	30%
Persons in Age Group Not Yet Vaccinated.	36,156	19,837	15,674	15,873	24,568	15,164	10,098	7,893	5,497	150,759
Percent of Age Group Not Yet Vaccinated	99.7%	90%	83%	80%	78%	75%	49%	43%	19%	70%
* Due to privacy concerns, vaccination figures are suppressed where less than 30 persons are vaccinated.										

7. COVID Mutation and Changes in Transmissibility/Virulence/Other

The emergence of a variant of the COVID-19 virus in the UK, classified as **B.1.1.7**, was identified in September and publicized in early December. Reports hold that B117 is 50% - 70% more contagious than our predominant variant now circulating (D614G). Within three months of the variant being identified in the UK it became dominant strain circulating there. Additional variants of concern have emerged internationally: **B1351** (South Africa) and Brazil (**P1**) which are also highly transmissible. **An additional variant, B1526, emerged in New York City in November. Its features are being studied.**

All variants appear to be significantly more transmissible than the virus which dominated Wave 1 of the pandemic.

The first three variants are spreading globally and have been detected in the US. The B117 and B1351 variants have been identified by the DPH as being in circulation in MA. The B1526 (NYC) variant now accounts for 40% of new cases in New York City.

Researchers are working to determine if the variants differ from D614G (the Wave 1 configuration) in terms of: **1.** How sick people become, **2.** If natural immunity is different following infection with D614G, and **3.** If immunity from vaccination differs since the vaccine was developed during the period that D614G has been predominant. **The existing vaccines may be less effective against the new strains. Moderna and Pfizer are working on booster shots to counter these new strains.**

The CDC is posting surveillance information on the emergence of the variants in the US: <https://www.cdc.gov/coronavirus/2019-ncov/transmission/variant-cases.html>.

According to an article by Andrew Joseph from StatNews, "Coronaviruses evolve more slowly than viruses like flu, but they do pick up mutations as they spread. **SARS-CoV-2 has been adding one or two changes a month to its RNA genome since it emerged late last year in China**, and different versions of the virus have been continuously circulating throughout the course of the pandemic. **But this variant (B.1.1.7 or VUI-202012/01) showed up with at least 17 mutations**, according to one genetic analysis."

(Source: https://www.statnews.com/2020/12/21/looming-questions-new-variant-coronavirus/?utm_source=STAT+Newsletters&utm_campaign=1a74bda2ca-MR_COPY_01&utm_medium=email&utm_term=0_8cab1d7961-1a74bda2ca-150158417).

Vaira Harik, M.S.
Deputy Director
Barnstable County Dept. of Human Services
Cell: 520-271-6314
Email: vharik@barnstablecounty.org

CONSENT AGENDA



HARWICH Police

DEPARTMENT

183 Sisson Road, Harwich, MA 02645

Tel 508-430-7541 Fax 508-432-2530



DAVID J. GUILLEMETTE
Chief of Police

KEVIN M. CONSIDINE
Deputy Chief

Memorandum

TO: Board of Selectmen

FROM: David J. Guillemette
Chief of Police 

DATE: 3/15/2021

SUBJECT: Nomination of Inspector of Animals

Chairman Ballantine and members of the Board, attached you will find a signed and notarized nomination form from the Commonwealth of Massachusetts Department of Agricultural Resources Division of Animal Health documenting the nomination of Jennifer Harrington as the Town of Harwich Animal Inspector for the coming year effective May 1, 2021 through April 30, 2022.

Jennifer is the current Animal Control Officer and the duties of Animal Inspector have run concurrent with the Animal Control position in Harwich. You will also note that Officer Robert Hadfield will not be put in for nomination this year as he has asked to be removed from the position.

I am asking that the Board of Selectmen as the appointing authority of the town vote to support the nomination of Jennifer Harrington. Thank you for your assistance in this matter.



The Commonwealth of Massachusetts

Department of Agricultural Resources
Division of Animal Health
251 Causeway Street, Suite 500
Boston, MA 02114-2151

Nomination of Inspector of Animals

In accordance with the Massachusetts General Laws Chapter 129, sections 15 and 16, nominating authorities of each city and town are required to nominate one or more inspectors of animals by April 1, 2021. Please complete or make necessary changes and return this form to the above address. The Director will review your nomination and, assuming appointment is confirmed, will return to you a Certificate of Appointment. Please submit one form for each person nominated. Any city or town not in compliance is subject to a penalty of \$500.

City or Town of Harwich

3/5/2021

To the Director, Division of Animal Health, Department of Agricultural Resources

In accordance with the provisions of section 15 of Chapter 129, General Laws, as amended, the following nomination of inspector of animals for the year ending April 30, 2022 is sent for your approval:

Inspector of Animals

Name: Jennifer Harrington
Mail Address: 183 Sisson Rd.
Harwich, MA - 02645
Phone: (508) 430-7541 Fax: (508) 432-2530
Email: jharrington@harwichpolice.com

Inspector: (Note all changes here)

Name: _____
Mail: _____
Phone: _____ Fax: _____
Email: _____

Nominating Authority

Contact: Larry Ballantine Chairman
Office: Board of Selectmen
Mail: 732 Main St.
Harwich, MA - 02645
P: (508) 430-7513 F: (508) 432-5039
Email: jpowers@town.harwich.ma.us

Nominating Authority: (Note all changes here)

Contact: _____
Office: _____
Mail: _____
Phone: _____ Fax: _____
Email: _____

Acceptance of Nomination of Inspector of Animals (must be notarized)

I hereby accept my nomination as Inspector of Animals for the City or Town of Harwich, and if and when I am appointed, I solemnly swear to faithfully perform the duties of that office, all of which are listed in General Laws Chapter 129, and Massachusetts Regulations 330 CMR 10.00-10.10 (rabies regulations).

Name (print) Jennifer L. Harrington Signed Jennifer L. Harrington
COMMONWEALTH OF MASSACHUSETTS

Barnstable, ss

Date: 3/15/2021

Then personally appeared the above-named Jennifer L. Harrington and acknowledged the foregoing instrument to be his or her free act and deed, before me.

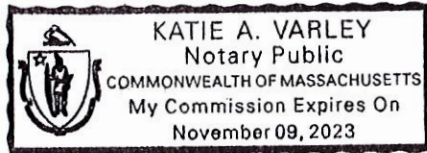

Katie A. Varley
Notary Public

My commission Expires: 11/9/2023

Appointment of Inspector of Animals (Division of Animal Health use only)

Notice is hereby given that I, Michael Cahill acting under authority of sections 15 and 16 of Chapter 129 of the General Laws, as amended, hereby approve the nomination of _____ as Inspector of Animals for the City or Town of Harwich, Massachusetts.

Date Approved: _____

Director, Division of Animal Health



The Commonwealth of Massachusetts

Department of Agricultural Resources
Division of Animal Health
251 Causeway Street, Suite 500
Boston, MA 02114-2151

Nomination of Inspector of Animals

In accordance with the Massachusetts General Laws Chapter 129, sections 15 and 16, nominating authorities of each city and town are required to nominate one or more inspectors of animals by April 1, 2021. Please complete or make necessary changes and return this form to the above address. The Director will review your nomination and, assuming appointment is confirmed, will return to you a Certificate of Appointment. Please submit one form for each person nominated. Any city or town not in compliance is subject to a penalty of \$500.

City or Town of Harwich

3/5/2021

To the Director, Division of Animal Health, Department of Agricultural Resources

In accordance with the provisions of section 15 of Chapter 129, General Laws, as amended, the following nomination of inspector of animals for the year ending April 30, 2022 is sent for your approval:

Inspector of Animals

Name: Robert Hadfield
Mail Address: 183 Sisson Rd.
Harwich, MA - 02645
Phone: (508) 430-7541 Fax: (508) 432-2530
Email: rhadfield@harwichpolice.com

Inspector: (Note all changes here)

Name: — VACANT —
Mail: _____
Phone: _____ Fax: _____
Email: _____

Nominating Authority

Contact: Christopher Clark
Office: Town Administrator's Office
Mail: 732 Main St.
Harwich, MA - 02645
P: (508) 430-7513 F: (508) 432-5039
Email: cclark@town.harwich.ma.us

Nominating Authority: (Note all changes here)

Contact: _____
Office: _____
Mail: _____
Phone: _____ Fax: _____
Email: _____

Acceptance of Nomination of Inspector of Animals (must be notarized)

I hereby accept my nomination as Inspector of Animals for the City or Town of Harwich, and if and when I am appointed, I solemnly swear to faithfully perform the duties of that office, all of which are listed in General Laws Chapter 129, and Massachusetts Regulations 330 CMR 10.00-10.10 (rabies regulations).

Name (print) _____ Signed _____

COMMONWEALTH OF MASSACHUSETTS

Barnstable,ss

Date: _____

Then personally appeared the above-named _____ and acknowledged the foregoing instrument to be his or her free act and deed, before me.

Notary Public

My commission Expires: _____

Appointment of Inspector of Animals (Division of Animal Health use only)

Notice is hereby given that I, Michael Cahill acting under authority of sections 15 and 16 of Chapter 129 of the General Laws, as amended, hereby approve the nomination of _____ as Inspector of Animals for the City or Town of Harwich, Massachusetts.

Date Approved: _____

Director, Division of Animal Health

THE COMMONWEALTH OF MASSACHUSETTS
EXECUTIVE OFFICE OF ENERGY AND ENVIRONMENTAL AFFAIRS



Department of Agricultural Resources

251 Causeway Street, Suite 500, Boston, MA 02114
617-626-1700 fax: 617-626-1850 www.mass.gov/agr



DEVAL L. PATRICK
Governor

TIMOTHY P. MURRAY
Lieutenant Governor

RICHARD K. SULLIVAN JR.
Secretary

SCOTT J. SOARES
Commissioner

March 5, 2021

RE: NOMINATION OF INSPECTOR OF ANIMALS

Nominating Authority:

Enclosed is the nomination form for the Inspector of Animals for your city or town. **This form is due back to the Division of Animal Health by April 1, 2021.** The appointment will run from May 1, 2021 until April 30, 2022. If more than one inspector was appointed for your city or town, there is a separate form for each. If you are nominating the same inspector(s) this year, **be sure that all of the contact information is complete and still correct.** Any corrections should be made in the space provided on the right. If you will be nominating a new inspector, that person's information should be entered in the space provided on the right. Submit a separate form for each inspector nominated. Also, be sure that all of your (nominating authority) information is complete and correct. Any changes to your information should be made in the space provided to the right.

Once all of the contact information is confirmed to be correct, all that is needed is to **have the nominee sign the form**, accepting the nomination and swearing to faithfully perform the duties of that office. **The nominee's signature must be notarized.** In many cases the city or town clerk is a notary.

After the nominee's signature has been notarized, simply **return the form to the Division of Animal Health at the address listed at the top of the form.** The Division of Animal Health will send back confirmation of the inspector's appointment. **Please note that regardless of when the most recent appointment was made, it is only valid through April 30, 2021.** This nomination will cover the year starting May 1, 2021 and run until April 30, 2022.

If you have any questions, please call Ashley Kraft at (617) 626-1810

Thank you,

Michael Cahill, Director
Division of Animal Health

March 22, 2021

Harwich Board of Selectmen
732 Main Street
Harwich, MA 02645

Dear Board of Selectmen:

I was pleased to learn that that MassDOT's Project Review Committee voted to accept the Saquatucket Harbor to Harwich Port sidewalk project on January 28, 2021, and that both the Banstable County Joint Transportation Committee and Metropolitan Planning Organization voted to place the project on the 2025 Transportation Improvement Program plan.

I would like to support the Town with a donation of \$250,000 to go towards the sidewalk engineering design. Please accept this letter as my pledge of \$250,000 to the Town of Harwich Board of Selectmen.

I appreciate everyone's hard work on this project.

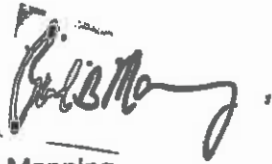

Paul B Manning

NEW BUSINESS

MAIN STREET
CRANBERRY BOG
LEASE AGREEMENT

Agreement made this 13th day of _____ November _____, 2001, between the Town of Harwich, through its Board of Selectmen, hereafter called the first party, and

_____ Leo G. Cakounes d/b/a Cape Farm Supply _____ is hereafter called the second party.

Whereas the first party is the owner of the following real property.

The premises known as Main Street Cranberry Bog located at 374 Main Street, North Harwich, Barnstable County, Massachusetts, shown on Harwich Assessors Map 47 as Parcel A-10, containing 33.6 acres, total, 10.7 acres of bog, 2 acres of cedar swamp and pond, and 21.6 acres of upland, more or less, and being further shown on a plan recorded in the Barnstable County Registry of Deeds in Plan Book 460, Page 55 and described in the deed recorded in Barnstable County Registry of Deeds Book 10792, Page 257. The town of Harwich 2001 Assessment for this property is \$620,000.

Whereas the first party has been authorized to lease said premises by the vote under Article 6 of the Special Town Meeting on August 6, 2001:

Whereas the first party issued a Request for Proposals dated July 19, 2001 (the "Request for Proposals"):

NOW THEREFORE, the first party agrees to lease to the second party the afore mentioned premises under the following terms and conditions:

The term of said lease shall be for twenty (20) years commencing November 13, 2001, and ending November 12, 2021, and the second party will pay to the first party rent as follows:

Payment as listed on the attached Cost Proposal Form – Exhibit C, submitted with the proposal, and in accordance with the specifications listed in the Request for Proposal.

The second party, after payment of rent to the town, shall be entitled to all profits realized as the result of the harvesting of said bog, and other agricultural practices in accordance with the provisions of this lease.

The second party agrees during the term of said lease hereof, in accordance with the contract document (s) as defined on page two (2) of this lease agreement, to properly maintain said bog in a good and efficient manner keeping said bog free from weeds and generally maintaining it in a productive condition. All costs of maintaining said bog shall be the responsibility of the second party, including utilities, proper irrigation and water supply. Care must be taken not to cause flood damage to adjacent properties. Failure to properly maintain said bog shall constitute a breach of the lease.

All uses of the leased premises by the second party shall be in accordance with the Contract Documents. During the term of this lease, the Conservation Commission shall have the right to utilize such portions of the leased premises as it deems necessary (including the existing bog roads) to carry out the management and control of the leased premises for preservation, conservation, and passive recreation, which may include public access. Such management and control shall not unduly interfere with the rights and obligations of the second party to properly conduct the operation of the cranberry bogs and proposed agricultural use as specified in the attached Sketch Plan (Exhibit F) of proposed use in accordance with the provisions of this lease. Any changes to the said attached use plan shall require prior review and recommendation of the Conservation Commission and prior written approval from the Board of Selectmen and shall be within the scope of the Request for Proposals.

The second party agrees to indemnify, defend with counsel approved by the first party, and hold harmless the said Town of Harwich (First Party) from any and all costs, claims and damages, including reasonable attorney's fees, which may be sustained by or asserted against the First Party as the result of the maintenance, operation and harvesting of said bogs or any other activity or condition on or of said bogs or the leased premises performed, allowed or suffered, whether permitted by this lease or not, by the second party.

There shall be no assignment of subletting of the leased premises.

Further, the second party agrees to abide by all applicable State, Federal local laws, by-laws and regulations, including without limitation those governing the maintenance and operation of cranberry bogs and governing the hiring of employees and covenants and agrees to do no act or thing which constitutes an unfair labor practice, or constitutes discrimination in employment and the second party agrees to maintain all necessary Workers Compensation insurance as well as liability insurance, as reasonably required from time to time by the First Party, which liability insurance shall name the first party as additional insured.

Any cranberry market order obtained by the town of Harwich can not be reassigned by the second party and shall remain the property of the town of Harwich.

The executed Contract Documents shall consist of the following:

- a. Legal Notice
- b. Request for Proposals (RFP)
- c. Specifications
- d. Three (3) signed copies of Lease Agreement
- e. Sketch Plan of Bogs (Exhibit A)
- f. Disclosure of Beneficial Interests in Real Property Transaction (Exhibit B)
- g. Three (3) signed copies of the Technical and Cost proposals (Exhibit C)
- h. Certificate of Non-collusion and Tax Compliance (Exhibit D)
- i. Reference Form (Exhibit E)
- j. Certificate of Insurance (provided by proposer)
- k. Currently Required Liability Coverage Limits
- l. Sketch Plan of Proposed Use (MAIN STREET BOG-Exhibit F)

IN WITNESS WHEREOF, the parties hereto have interchangeably set their hands and seals to this and to another instrument of like tenor the day and year first written above.

TOWN OF HARWICH BOARD OF SELECTMEN:

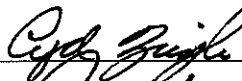

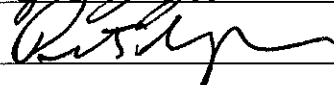



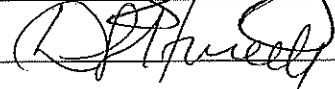

SECOND PARTY:



 1/6/a Cape Farm Supply

Approval as to form of Lease Agreement:

Jeanne McKnight, Kopelman & Paige
Town Counsel

Date: November 13, 2001

EXHIBIT F
Sketch Plan of Proposed Use

MAIN STREET
CRANBERRY BOG
LEASE AGREEMENT

Leo G. Cakounes d/b/a Cape Farm Supply

Please see the attached Sketch Plan of Proposed Uses for the uplands of the bogs.

Signature  Date NOV 15 2001

PROPOSED FENCE AROUND
 PASTURE AREA 2 AND ALONG
 FRONT TO LIMIT DRIVE IN
 TRAFFIC - PARKING
 OFF STREET FOR
 WALKERS.

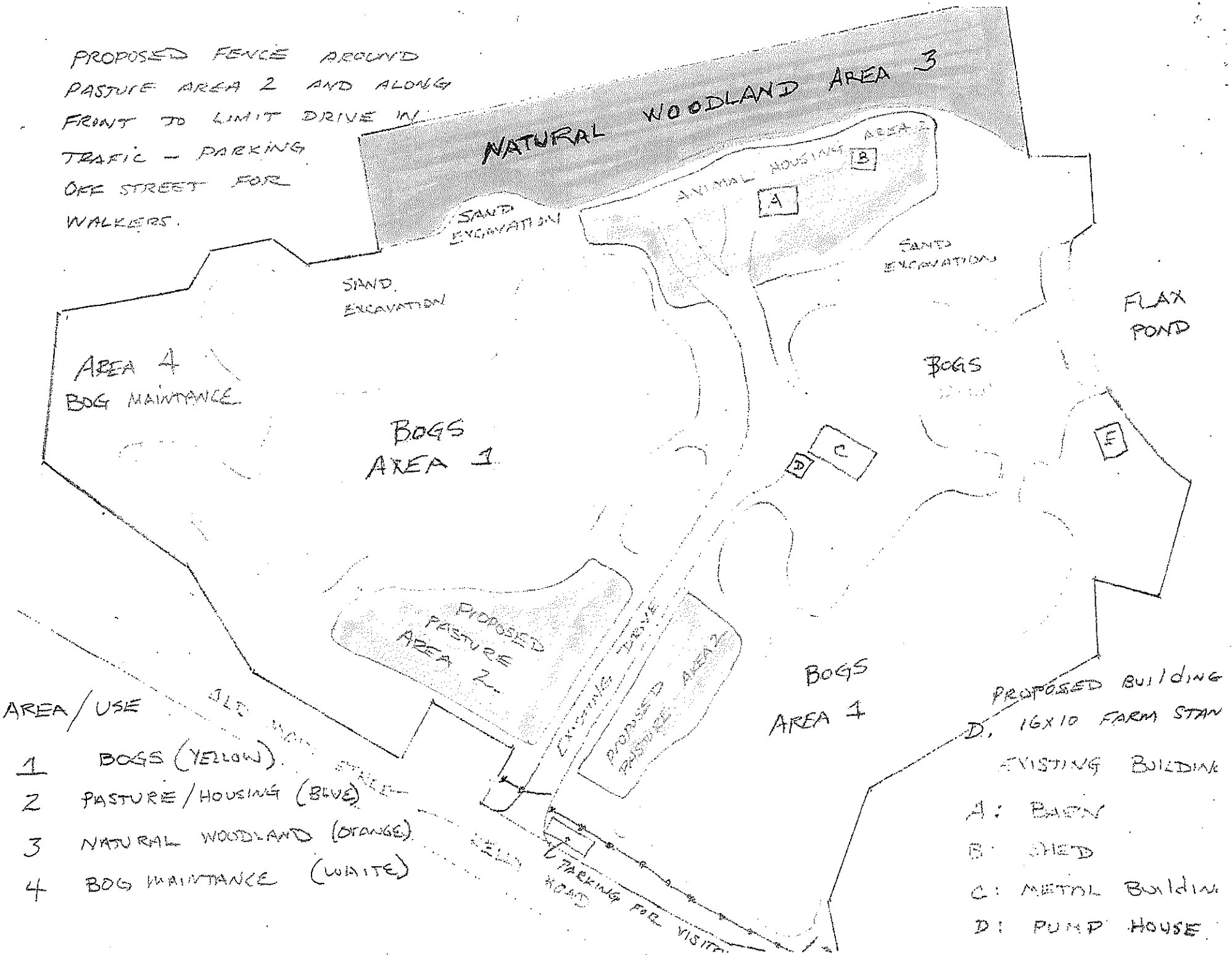

- AREA / USE
- 1 BOGS (YELLOW)
 - 2 PASTURE / HOUSING (BLUE)
 - 3 NATURAL WOODLAND (ORANGE)
 - 4 BOG MAINTANCE (WHITE)

- D: 16X10 FARM STAN
- EXISTING BUILDING
- A: BARN
- B: SHED
- C: METAL BUILDING
- D: PUMP HOUSE

AREA 1:

PRODUCTIONS OF CRANBERRIES, MAINTANCE OF
BOGS AS TO THEIR PRODUCTION OF BERRIES.

AREA 2:

FENCED IN PASTURE AREA FOR GRAZING OF
ANIMALS. LOCATED ALONGSIDE OF DRIVEWAY

AREA TO REAR OF PROPERTY, REBUILD EXISTING
BARN & SHED FOR ANIMAL HOUSING.

CREATE SOME FENCING FOR CONTAINMENT OF
ANIMALS LE: CHICKENS, SHEEP, HORSE, COW
ETC. IN MOST CASES THE FENCING USED WILL
BE CHAIN LINK RENEWEL TYPE. REMOVEABLE AND
INTERCHANGEABLE.

ELECTRICITY AND WATER EXIST IN BUILDINGS
NOW AND WILL BE MAINTAINED.

AREA 3:

NATURAL WOODLAND: THIS AREA IS SET ASIDE AS
NATURAL WOODED AREA FOR WILDLIFE AND NATURE
WALK ACCESS.

I WILL MAINTAIN THE AREA IN CONJECTION WITH
MUNICIPAL FORESTRY COMMITTEE.

AREA 4:

BOG MAINTANCE AREA.

AS DESIGNATED AREAS FOR SAND EXCAVATION
 FOR BOG MAINTANCE
 ALSO ROADWAYS AROUND BOG FOR ACCESS
 AND BOG MAINTANCE.

AS TO THE IRREGULARITY OF SHAPE OF
 Bogs we intend to propose to the commission
 A PLAN TO STAVE OFF AREAS, THIS WILL
 NOT BE DONE FOR SOMETIME BUT IT IS IN
 OUR RECLAIMING AND REBUILDING PLAN IN FUTURE.

SAND EXCAVATION SITES EXIST AS OF 10/10/01
 AND WILL BE OUR SOURCE UNLESS OTHERWISE
 CHANGED WITH COMMISSIONS APPROVAL IN FUTURE.

We intend to HAVE AREAS FOR MULCHING
 OF WEEDS AND DEBRIS REMOVED FROM Bogs
 AND ACCESSWAYS.

The CONSTRUCTION OF BUILDING "D" WHICH WILL
 BE OUR FARM STAND IS PROPOSED. THIS IS
 A 10X16 SHED WITH SM. DECK & ROOF.

AREA 4 CONTINUED:

ALONG MAIN STREET A FENCE WILL BE INSTALLED WITH GATE ON DRIVEWAY AND DOG ACCESS ROAD TO EAST.

A PARKING AREA OF STREET WILL BE CREATED TO ALLOW THE PUBLIC TO PARK AND WALK AROUND AREA 4 AND ACCESS AREA 3 BY FOOT.

OTHER FENCING AND GATES MAY HAVE TO BE INSTALLED TO CONTROL ACCESS AND USE, I.E. THE TRAVEL BY HORSE, MOTOR BIKE, BICYCLE, OR MOTOR VEHICLE. MOST CONCERN IS ROADWAY TO WEST OF PROPERTY AND IT'S POSSIBLE USE BY UNSUPERVISED CHILDREN.

THROUGHOUT THE PROPOSAL WE ENCOURAGE THE PUBLIC'S ACCESS TO THE PROPERTY. YET WE BELIEVE IN EQUAL USE, SHARED USE, AND MOST OF ALL SAFE USE. THIS CAN ONLY BE ACCOMPLISHED WITH CONTROL AND SUPERVISION.

ACORD CERTIFICATE OF LIABILITY INSURANCE

DATE (MM/DD/YY)
11/20/2001

PRODUCER
MARK SYLVIA AGENCY
770A MAIN STREET
OSTERVILLE, MA 02655

508-428-0440

THIS CERTIFICATE IS ISSUED AS A MATTER OF INFORMATION ONLY AND CONFERS NO RIGHTS UPON THE CERTIFICATE HOLDER. THIS CERTIFICATE DOES NOT AMEND, EXTEND OR ALTER THE COVERAGE AFFORDED BY THE POLICIES BELOW.

INSURERS AFFORDING COVERAGE

INSURED
LEO G. CAKOUNES
4 SPRINGTIDE LN.
HARWICH, MA 02645

INSURER A. FARM FAMILY CASUALTY INSURANCE COMPANY
INSURER B.
INSURER C.
INSURER D.
INSURER E.

COVERAGES

THE POLICIES OF INSURANCE LISTED BELOW HAVE BEEN ISSUED TO THE INSURED NAMED ABOVE FOR THE POLICY PERIOD INDICATED NOTWITHSTANDING ANY REQUIREMENT, TERM OR CONDITION OF ANY CONTRACT OR OTHER DOCUMENT WITH RESPECT TO WHICH THIS CERTIFICATE MAY BE ISSUED OR MAY PERTAIN. THE INSURANCE AFFORDED BY THE POLICIES DESCRIBED HEREIN IS SUBJECT TO ALL THE TERMS, EXCLUSIONS AND CONDITIONS OF SUCH POLICIES. AGGREGATE LIMITS SHOWN MAY HAVE BEEN REDUCED BY PAID CLAIMS.

INSR LTR	TYPE OF INSURANCE	POLICY NUMBER	POLICY EFFECTIVE DATE (MM/DD/YY)	POLICY EXPIRATION DATE (MM/DD/YY)	LIMITS
	GENERAL LIABILITY				EACH OCCURRENCE \$
	COMMERCIAL GENERAL LIABILITY				FIRE DAMAGE (Any one fire) \$
	CLAIMS MADE OCCUR				MED EXP (Any one person) \$
					PERSONAL & ADV INJURY \$
					GENERAL AGGREGATE \$
	GEN. AGGREGATE LIMIT APPLIES FOR				PRODUCTS - COMP/OP AGG \$
	POLICY PROJECT LOC				
	AUTOMOBILE LIABILITY				COMBINED SINGLE LIMIT (Ea accident) \$
	ANY AUTO				BODILY INJURY (Per person) \$
	ALL OWNED AUTOS				BODILY INJURY (Per accident) \$
	SCHEDULED AUTOS				PROPERTY DAMAGE (Per accident) \$
	HIRED AUTOS				
	NON-OWNED AUTOS				
	GARAGE LIABILITY				AUTO ONLY - EA ACCIDENT \$
	ANY AUTO				OTHER THAN ALTO ONLY EA ACC \$
					AGG \$
	EXCESS LIABILITY				EACH OCCURRENCE \$
	OCCUR CLAIMS MADE				AGGREGATE \$
					\$
	DEDUCTIBLE				\$
	RETENTION \$				\$
	WORKERS COMPENSATION AND EMPLOYERS' LIABILITY				WC STATUTORY LIMITS OTHER
					E L EACH ACCIDENT \$
					E L DISEASE - EA EMPLOYEE \$
					E L DISEASE - POLICY LIMIT \$
OTHER	A SPECIAL FARM PACKAGE	2001 G 1280	05-21-01	05-21-02	LIABILITY 1,000,000
	10				

DESCRIPTION OF OPERATIONS/LOCATIONS/VEHICLES/EXCLUSIONS ADDED BY ENDORSEMENT/SPECIAL PROVISIONS
PROPERTY INSURED FOR A CRANBERRY FARM AT 374 MAIN STREET, HARWICH, MA 02645.
THE TOWN OF HARWICH IS NAMED AS AN ADDITIONAL INSURED

CERTIFICATE HOLDER

ADDITIONAL INSURED; INSURER LETTER: X

CANCELLATION

TOWN OF HARWICH
C/O RON SANDERS ASSISTANT TOWN
ADMINISTRATOR
732 MAIN STREET
HARWICH, MA 02645

SHOULD ANY OF THE ABOVE DESCRIBED POLICIES BE CANCELLED BEFORE THE EXPIRATION DATE THEREOF, THE ISSUING INSURER WILL ENDEAVOR TO MAIL _____ DAYS WRITTEN NOTICE TO THE CERTIFICATE HOLDER NAMED TO THE LEFT, BUT FAILURE TO DO SO SHALL IMPOSE NO OBLIGATION OR LIABILITY OF ANY KIND UPON THE INSURER, ITS AGENTS OR REPRESENTATIVES.

AUTHORIZED REPRESENTATIVE

VI. BID PAYMENT BREAKDOWN

I have taken a base payment of \$2,500 annually and increased it by 2-½% each year to arrive at the payment schedule.

The base of \$2,500 was arrived at by the amount of tax revenue received by the Town if the property were to be held privately and taxes were paid on it under Chapter 61A.

The 2-½% increase was used as a factor because of the Town's revenue steadily increases by that amount with the exception made for override vote items.

(Please see the following attached sheets and receipts for calculations.)

LEASE OF CRANBERRY BOGS – COST PROPOSAL/BID FORM

The price proposals submitted for review can be graduated or fixed amounts in yearly payments. Proposals must specify how they arrived at said payment, *i.e. based on yearly yield of crop projected by past production or Cranberry Marketing Order.*

Also, specify if lease payments are subject to Production, Market Price, or Guaranteed each year.

ACKNOWLEDGEMENT OF RECEIPT OF ANY ADDENDA _____ (list ALL received)

1. MAIN STREET BOG - \$63,859 Total over 20 year lease. THE ANNUAL LEASE PAYMENTS ARE GUARANTEED.

(Please fill in each year with a dollar amount or \$0.00.)

Annual Lease Payment Plan

2002	\$2500	2006	\$2759	2010	\$3046	2014	\$3362	2018	\$3711
2003	\$2562	2007	\$2828	2011	\$3122	2015	\$3446	2019	\$3804
2004	\$2626	2008	\$2899	2012	\$3200	2016	\$3532	2020	\$3899
2005	\$2692	2009	\$2971	2013	\$3280	2017	\$3620	2021	\$4000

2. CHATHAM BOG (It is the Proposer's intent not to respond on this Bog)

Cost Proposals for each bog will be submitted in duplicate, in the same sealed envelope as the TECHNICAL Proposal. Each should be clearly marked "LEASE OF CRANBERRY BOG – COST & TECHNICAL PROPOSAL/CHATHAM or /MAIN STREET (indicate which bog)". Prices must be submitted using this Cost Proposal form (2 copies are included in the RFP for your convenience.

Proposer Name, Address: CAPE FARM SUPPLY
LEO G. CAKOUNES
4 Springtide Lane, Harwich Port, MA

Signature: _____

Date: 8/17/01

(Above must be a signature of a person authorized to sign and contract for the Company.)

QUITCLAIM DEED

Main St. Cranberry Co., L.L.C., a Massachusetts limited liability company, c/o 26 George Ryder Road So., West Chatham, MA 02669,

in consideration of Six Hundred Twenty-Six Thousand Four Hundred Nine Dollars (\$626,409.00) paid

grant to the Town of Harwich, a Massachusetts municipal corporation, with an address of 732 Main Street, Harwich, MA 02645, to be under the jurisdiction of the Conservation Commission pursuant to M.G.L. c.44, §8C, as authorized by the vote under Article 11 of the Town of Harwich Special Town Meeting held on May 2, 2000, a certified copy of which is attached hereto as Exhibit A,

with QUITCLAIM COVENANTS

The land located in Harwich (North) Barnstable County, Massachusetts bounded and described as follows:

Parcel 1:

The land containing 1, 463, 628 +/- square feet, or 33.6 acres - total, all as more fully shown on a plan entitled "Plan of Land in Harwich, Mass. For: Rodney A. O'Brien & Ellen C. O'Brien, Plan By: Moran Engineering, Inc. 941 Main Street S. Harwich, Mass. Scale: 1"=80' March 18, 1989" and recorded in Plan Book 460 Page 55 at the Barnstable County Registry of Deeds, excluding, however, that portion of the land containing structures.

Said premises are conveyed subject to and with the benefit of any and all rights, rights of way, easements, reservations, restrictions or other conditions of record insofar as the same may be in force and applicable.

Said premises may be used only for the purposes set forth in Chapter 293 of the Acts of 1998, the Cape Cod Open Space Land Acquisition Program, as amended.

Parcel 2:

All that portion of the land containing structures and shown on the above-mentioned plan recorded in Barnstable Plan Book 460 Page 55.

Said premises are conveyed subject to and with the benefit of any and all rights, rights of way, easements, reservations, restrictions or other conditions of record insofar as the same may be in force and applicable.

The grantor and the grantee acknowledge that monies from the Cape Cod Open Space Land Acquisition Program have been used only to fund the purchase of Parcel 1, Parcel 2 is being conveyed as a gift for no consideration.

For title reference see the deed from Rodney A. O'Brien and Ellen C. O'Brien recorded in Book 10792, Page 259 and the deed from Irene M. Crowell to be recorded herewith. Meaning and intending to convey all the premises shown on Plan Book 460, Page 55.

The street address of the property is: 374 Main Street, North Harwich, MA 02645.

Executed as a sealed instrument this 11th day of July, 2000.

Main St. Cranberry Co., L.L.C.

By: 
John McAbee

By: 
Cleveland Smith

COMMONWEALTH OF MASSACHUSETTS

BARNSTABLE, SS.

July 11, 2000

Then personally appeared the above-named John McAbee and acknowledged the foregoing instrument to be their free act and deed, and the free act and deed of Main St. Cranberry Co., L.L.C., before me,

Notary Public:
My commission expires: 10/21/05



COMMONWEALTH OF MASSACHUSETTS

BARNSTABLE, SS.

July 11, 2000

Then personally appeared the above-named ~~John McAbee~~ ^{Cleveland Smith} and acknowledged the foregoing instrument to be their free act and deed, and the free act and deed of Main St. Cranberry Co., L.L.C., before me,



Notary Public: Jennifer S. Esposito
My commission expires: 11/03/2002



Exhibit A

BK13127 PG215 43723

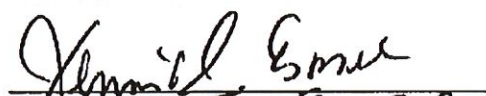
TOWN OF



HARWICH

Anita N. Doucette, CMC/AAE/CMMC
Town Clerk

732 Main Street
Harwich, Massachusetts 02645
Tel. 508-430-7516
FAX 508-432-5039

TOWN OF HARWICH
SPECIAL TOWN MEETING
MAY 2, 2000

ARTICLE 11. ACQUIRE LAND OF MAIN ST. CRANBERRY CO. L.L.C.

ARTICLE 11. To see if the Town will vote to authorize and direct the Board of Selectmen to acquire by gift, by purchase, by eminent domain or otherwise, for preservation, open space, conservation, agricultural and passive recreation purposes, all or a portion of the property, situated at 374 Main Street, North Harwich, shown on Harwich Assessors Map 47 as Parcel A-10, containing 33.6 acres, more or less, and being further shown on a plan recorded in the Barnstable County Registry of Deeds in Plan Book 460 Page 55 and described in the deed recorded in Barnstable County Registry of Deeds Book 10792 Page 257, being owned by Main St. Cranberry Co. L.L.C; and to transfer from available funds, or borrow a sufficient sum of money for such acquisition. Provided that the Conservation Commission be authorized to file on behalf of the Town any and all applications deemed necessary for grants and/or reimbursements from the Commonwealth of Massachusetts deemed necessary under the Self-Help Act (Chapter 132A, §11) and /or any others in any way connected with the scope of this article, and that the Board of Selectmen be authorized to negotiate the purchase of the property and be authorized to make the decision to enter into any agreement to purchase the property and to execute any and all instruments as may be necessary on behalf of the Town and to act fully thereon. By request of the Real Estate and Open Space Committee. Estimated cost: \$630,000.00.

MOTION: (Carol Thayer, Chairman-Finance Committee) I move that this article be accepted and adopted and that the sum of \$630,000.00 be appropriated for the purpose of purchasing and/or taking by eminent domain, all the property described in the article for preservation, open space, conservation, agricultural and passive recreational purposes, including, without limitation, the authority to lease all or portions of the property for agricultural purposes, and that to raise such appropriation the treasurer, with the approval of the Board of Selectmen, be authorized to borrow the sum of \$630,000.00 pursuant to Section 7 of Chapter 293 of the Acts of 1998 entitled "An Act Relative to the Establishment of the Cape Cod Open Space Land Acquisition Program" as amended, or any other enabling authority, and to issue bonds or notes of the Town therefore, said property to be managed and controlled by the Conservation Commission pursuant to General Laws Chapter 40 Section 8C, and further that the Board of Selectmen and the Conservation Commission be authorized to take all actions necessary to carry out the purchase of the property in accordance with the provisions of the article and this vote.

(Duly seconded)

ACTION: This article needs a 2/3 majority vote to pass. It is a unanimous vote, so declared.

A true copy
Attest
Anita N. Doucette
Anita N. Doucette, Town Clerk

JUL 11 2000

BARNSTABLE REGISTRY OF DEEDS



732 MAIN STREET, HARWICH, MA 02645

March 24, 2021

Noreen Mavro-Flanders, Chair
Cape Cod Municipal Health Group
c/o Group Benefits Strategies
15 Midstate Drive, Ste. 110
Auburn, MA 01501

Dear Ms. Mavro-Flanders:

At a public meeting of the Board of Selectmen held on Wednesday, March 24, 2021 the Board discussed the appointment of a person to replace Christopher Clark as Harwich's representative on the Board of Directors of the Cape Cod Municipal Health Group.

Following this discussion, the Board of Selectmen voted to appoint Harwich Town Administrator, Joseph F. Powers as the representative from Harwich. Amy Bullock, Treasurer/Collector, will remain as the alternate representative to the group. Contact information is as follows:

Joseph F. Powers
Town Administrator
Town of Harwich
732 Main Street, Harwich, MA 02645
(508) 430-7513 ext. 3321
jpowers@town.harwich.ma.us

Sincerely,

HARWICH BOARD OF SELECTMEN

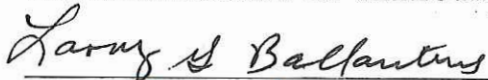

Larry G. Ballantine, Chair

Edward J. McManis, Vice Chair

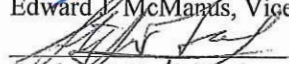
Stephen P. Ford, Clerk

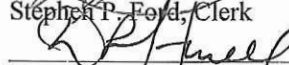
Donald F. Howell

Michael D. MacAskill



Town of Harwich COUNCIL ON AGING

Harwich Community Center □ 100 Oak Street □ Harwich, MA 02645
Tel: 508-430-7550 Fax: 508-430-7530

m e m o

TO: Board of Selectmen

CC: Joseph Powers, Town Administrator
Meggan Eldredge, Assistant Town Administrator

FROM: Emily Mitchell, COA Director *Emily Mitchell*

DATE: March 22, 2021

RE: **Request to Renew Memorandum of Agreement with Social Security Administration**

The Harwich Council on Aging has partnered with the Social Security Administration (SSA) to provide residents with access to the full scope of SSA services through Video Service Delivery (VSD) project since 2015. This project allows for real-time teleconference communication between Harwich residents and staff members at the Hyannis SSA Field Office. This renewal of the MOA will cover a five year period from the date the last party signs the agreement.

Broadly speaking, under this MOA, the COA is responsible for providing a secure space for the VSD equipment and offering limited assistance to residents seeking to utilize this service. The SSA is responsible for the installation, maintenance, and upgrade of the VSD equipment. Where this is a renewal, the equipment is already installed. There is no exchange of funds between the parties.

When serving as Acting Assistant Town Administrator, Robert Lawton has the MOA reviewed by Town Counsel and MIIA. Counsel had no concerns and MIIA affirmed that the equipment would be covered under the Town's Umbrella Liability policy.

This service is invaluable for Harwich residents. It holds particular value for individuals without access to transportation and therefore unable to travel to the Hyannis SSA office without significant hardship, as well as for residents without independent access to internet or technology. In the last five years, hundreds of residents have utilized this service. We look forward to continuing this partnership for the benefit of our community.

Recommendation: I recommend that the Board of Selectmen authorize the Chair to sign the attached Memorandum of Agreement between the Harwich Council on Aging and the Social Security Administration, renewing our participation in the Video Service Delivery project for an additional five years.

MEMORANDUM OF AGREEMENT
between
Harwich Council on Aging
and
The Social Security Administration

I. Purpose

This agreement, entered into by and between the Harwich Council on Aging, 100 Oak Street, Harwich, MA 02645 and the Social Security Administration (SSA), Boston Regional Office, 15 New Sudbury Street, JFK Federal Building, Room 1900, Boston MA 02203, (together, “the parties”), sets forth the terms and conditions regarding the parties’ participation in SSA’s Video Service Delivery (VSD) project. The goal of the VSD project is to reach out to members of the public who wish to conduct business with SSA, in remote locations, through real-time video conferencing in order to provide them with better information and access to SSA services. This project will test the impact of SSA’s VSD initiative on its internal network and operations, and on the residents of Harwich.

II. Authority

The authority for SSA to provide services under this agreement is sections 205(a), 701(b), and 702(a)(4) - (7) of the Social Security Act [42 U.S.C. §§ 405(a), 901(b), and 902(a)(4) – (7)].

III. Responsibilities of the Parties:

A. Harwich Council on Aging (Facility) will:

1. Permit SSA to use the facility’s Internet Protocol (IP) Medium to install video equipment. SSA will not use the facility’s IP connection unless both parties agree upon it. Otherwise, SSA will install a separate internet transport medium at the facility.
2. Provide secure space for video teleconferencing equipment in the Facility.
3. Provide limited assistance to the members of the public wishing to use the SSA equipment.
4. Ensure that Facility employees understand that they will not have access to SSA data or systems.
5. Ensure that Facility employees will gather any personal belongings or records left at the Facility by individuals and mail the belongings or records to the SSA Field Office at 100 Independence Drive, Hyannis, MA 02601.
6. Ensure that Facility employees who gather the belongings or records will not use or disclose to any other party information contained in an individual’s records or belongings.

7. Ensure that Facility employees will take reasonable steps to protect the SSA provided Video and network equipment from damage, misuse, or theft.
8. Provide feedback to SSA on the use and effectiveness of the VSD project.
9. Assume liability for damage to the SSA equipment resulting from the intentional and malicious acts of Facility employees, as permitted by law. Facility will not be liable for accidental damage to the equipment.

B. SSA will:

1. Assume responsibility for the installation, maintenance, and upgrade of any SSA provided transport medium and video teleconferencing equipment at the Facility for purposes of the VSD project.
2. Require its contractor to be sufficiently bonded and insured. Documentation of this bonding and insurance will be provided to the Facility prior to installation of the transport medium.
3. Provide information on the use of the equipment to its customers.
4. Provide feedback to the Facility on the use and effectiveness of the VSD project.
5. At the conclusion of the project, discontinue service to the transport medium but allow the wiring for the line to remain in place, and remove video teleconferencing equipment.

IV. Duration, Modification, Termination

This agreement will be effective upon approval and signature of the parties, beginning on the date that the last party signs, and will remain in effect for a period of five years. Modifications to this agreement must be in writing and agreed to by the parties. This agreement may be terminated by either party upon sixty (60) days advance written notice, which shall be delivered to the other party by hand or by certified mail.

V. Financial Arrangements

The parties shall bear their own costs related to their responsibilities under this agreement. The Facility has no expectation of any payment by SSA for services or rent, and SSA shall not reimburse the Facility for any such costs related to this agreement. SSA shall bear its expense related to the installation, maintenance, operation, and upgrade of the transport medium and video teleconferencing equipment.

SSA will be responsible for any financial loss or other loss incurred as a result of SSA's negligence or the negligence of its employees operating within the scope of their employment

pursuant to the Federal Torts Claims Act (FTCA), 28 U.S.C. §§ 1346, 2671, *et seq.*, as well as SSA's corresponding regulations found at 20 C.F.R. Part 429. Likewise, the Facility will be responsible for any financial loss or other loss incurred by the SSA as a result of the Facility's negligence or the negligence of its employees.

VI. Points of Contact

The Facility: Harwich Council on Aging
Name: Emily Mitchell
Title: Director
Address: 100 Oak Street, Harwich, MA 02645
Phone: 508-430-7550

SSA: Hyannis, MA Field Office
Name: Caitlin Gaessler
Title: District Manager
Address: 100 Independence Drive, Hyannis, MA 02601
Phone: 866-467-1426

VII. Privacy

Both parties will respect the privacy of the Facility's patrons and members of the public contacting SSA via the VSD project, and will work closely to ensure that all Facility and SSA personnel will accord personally identifiable information the highest level of protection from unauthorized disclosure. Personally identifiable information is any information about an individual maintained by an agency, including (1) any information that can be used to distinguish or trace an individual's identity, such as name, social security number, date and place of birth, mother's maiden name, or biometric records; and (2) any other information that is linked or linkable to an individual, such as medical, educational, financial, and employment information. To safeguard the public's privacy, no personally identifiable information relating to the Facility's patrons or SSA claimants will be exchanged between SSA and the Facility.

VIII. Dispute Resolution

The parties pledge to work collaboratively to resolve disputes arising from activities performed under this Agreement. Disputes will be resolved promptly and at the lowest level of authority. If the Designated Contact Points for the parties cannot resolve a dispute, the Head of the Facility and the Designated SSA Official will make every effort to resolve any disputes resulting from this Agreement.

IX. Integration Clause

This agreement constitutes the entire arrangement of the parties with respect to its subject matter. There have been no representations, warranties or promises made outside of this

agreement. This agreement shall take precedence over any other documents that may be in conflict with it.

X. Signatures

The signatories below warrant that they have the competent authority on behalf of their respective entity entities to enter into the obligations set forth in this agreement and that their signatures bind the parties.

For Facility: Larry Ballantine
Chair, Harwich Board of Selectmen

Signature: _____ Date: _____

For SSA : Anatoly Shnaider
Regional Commissioner
Boston Region

Signature: _____ Date: _____

**MINUTES
SELECTMEN'S MEETING
GRIFFIN ROOM, TOWN HALL
MONDAY, JUNE 17, 2019
6:30 P.M.**

SELECTMEN PARTICIPATING: Larry Ballantine, Stephen Ford, Donald Howell, Michael MacAskill, Edward McManus.

ALSO PARTICIPATING: Town Administrator Christopher Clark, Assistant Town Administrator Joseph Powers

CALL TO ORDER

Mr. Ballantine opened the meeting at 6:30 pm, and called to order the Board of Selectmen.

WEEKLY BRIEFING

A. Ms. Amy Usowski, Conservation Administrator, said she had two items to report on that the Selectmen and the Town should know about. First, as of this morning they have an advisory closure for swimming at Hinkley Pond, due to the start of a low-level blue-green algal bloom. The levels are not so bad that they need to be closed, but there will be continued sampling and hopefully they can lift that soon.

Ms. Usowski also provided an update on their piping plover and tern situation. They have one pair at Red River beach still has one chick, out of four that hatched, which is due to fledge, or fly, around June 26th. Barricades have been put up at the parking lot to protect the unfledged chick, but will be able to be removed before the July 4th holiday.

There also have eight chicks between Wychmere Harbor Club and the Pilgrim Road area. Chicks are due to fledge before July 4th. There is symbolic fencing up in both areas mentioned above to protect the chicks, which is required by state law. The public is advised to stay out of fenced areas. Fenced areas do not restrict the public's access to the water and the Town provides other beaches without symbolic fencing. If people and their animals do not respect restrictions and chicks do not survive, there is a chance plover pairs will re-nest, which could extend restrictions further into the summer. Please be mindful and respect what is in place.

Ms. Usowski said that they also have Common and Least Terns, but they do not have any restricted activities or areas because they are not nesting here.

- B. Deputy Fire Chief David LeBlanc, Harwich Fire Department, announced that the Fire Department was able to secure a summer intern, Mr. Michael Pandiscio from the University of New Haven. He will be helping out with pre-fire planning and going in to find out where alarm systems are located to develop these plans. As part of this there is a software package that they were able to contract to do and they found out today that they were able to get a \$2,500 grant from Factory Mutual to pay for the first year of the software and for a tablet for the fire inspector to go out and collect the data to do these pre-plans.

Mr. Ballantine asked where the plans are directed at?

Deputy Fire Chief LeBlanc said mostly commercial properties, what they would call target hazards. These would be bigger buildings, that have some type of fire suppression system, that would be a more complicated response for the Fire Department, such as; The Belmont, Wychmere Harbor Club, Town Hall and the Community Center.

Mr. Ballantine asked if they were inventorying hazardous waste as well? Deputy Fire Chief LeBlanc replied that they are not.

PUBLIC COMMENTS/ANNOUNCEMENTS

- A. Mr. Duncan Barry of West Harwich, said he had two items to bring to the attention of the Board. First there is an exposition for the Harwich Historical Society that opened yesterday and is dedicated to the houses of Captain's Row. It is a full expository of everything from the settlement in the 1650s down to recent and post-World War II roadside architecture. He added that it also makes a case for proper zoning of the area, which they will be bringing to the Board at a later date. He also noted that if anyone was interested in a tour, he would be happy to take care of it at their convenience.

Mr. Barry also wanted to bring to their attention a letter that he thinks they will find instructive. It is a letter date June 20, 2017 from the Chairman of the Eastham Board of Selectmen and it is a discretionary referral for the Cape Cod Commission to consider a DRI, which is how they manage to side step dropping a Dollar General

store along 6A in Eastham. He said it was a simple up and down vote with three criteria, one of which was the character of the area. He said it goes without saying that dropping an almost 8,000 square foot commercial building with parking in front, in the area of West Harwich that they are talking about, is completely disruptive to the character of the area, the historical nature of the area, as well as the traffic of the area. He would like to submit this to the Board of Selectmen to see how easy this can be done.

Mr. Ballantine said he understood this was at the Planning Board and they are determining if they want to send it to the commission or not.

Mr. Barry said perhaps, but what they have heard is that in both Deerfield and Eastham, it was done by the Board of Selectmen, regardless of what the Planning Board did. They are just going with the template that was considered both correct and the precedent.

Mr. Ballantine said he likes to use their normal processes if they can, but he is glad that Mr. Barry has been able to get the word out.

Mr. Ford said that he attended the Planning Board meeting and believes there are two avenues of referral to the commission. One is through the Planning Board and the other is through the Board of Selectmen.

Mr. Ballantine said ok, then they can put that on the agenda later.

- B. Ms. Jeannie Wheeler, Trustee of Brooks Free Library, read an invitation from the staff and trustees of Brooks Free Library for the Board of Selectmen and the public. Their invitation is to join them on Saturday, June 29th from 2:00 pm to 4:00 pm for the celebration of the completion of the Restoration and Preservation Project. They hope everyone can join them and thanks everyone for their support.
- C. Ms. Cyndi Williams, Executive Director of the Harwich Chamber of Commerce, announced the annual Harwich Chamber Charitable Foundation's Run for Harwich Youth, which will affect Route 28 to South Street, from 9:15 am to 11:30 am on Saturday.
- D. Ms. Sheila House, Harwich Youth and Family Services, announced two retirements from the Harwich Youth Services Committee. She said that Ms. Barbara Segal who is a Harwich parent and psychotherapist and began her service in 2009 and has been a really valuable resource and a really fun volunteer. The second person is really who she wanted to recognize tonight. Mr. Jim Hartley served on the Committee

since its inception almost 19 years ago and he is retiring from the board. Mr. Hartley was the Director of Student Services for Harwich High School for many years and he was chosen to be on the study committee when the town was formulating the position of Youth and Family Councilor. Mr. Hartley believed and continued to believe the importance of support for our kids. She would like to thank him.

Mr. Hartley appreciated the Town for being family oriented and geared toward children. In his work and volunteer time he was always impressed by the work that they do and he thanked them very much.

- E. Ms. Virginia Hewitt, Director, Brooks Free Library, said that she had two announcements. First on June 6th their Assistive Technology Coordinator, Carla Burke, was honored by the Carol Center for the Blind and Mass Commission for the Blind for the Thomas Carol Award for Employment. They recognized her as the blind employee of the year for Massachusetts. This award recognizes blind and visually impaired employees who have made significant contributions to their organizations. Individuals are chosen because despite vision loss, they are exemplary employees and contribute to the overall culture of their organization and to the community. Ms. Burke coordinate their VITAL program (Vision Impaired Technology Assistance at the Library), this program is in its 16 years of operation and through this program they teach people with vision loss to be independent users of technology. Ms. Burke continues to be a role model and an advocate for people with vision loss.

Ms. Hewitt next wanted to announce the start of their Summer Reading Program. She said that youngsters can log there reading and receive a free book and a prize. They replaced reading prizes with “Maker Kits”, which have been very popular. They will be having a big Recreating and Reading kick-off event, where families can sign their youngsters up for Summer recreation programs and the reading program. This will be held on the field behind the Community Center starting at 5:00 pm with free hotdogs and games and then a magic show at 6:00 pm.

Lastly, Ms. Hewitt said that the Friends of Brooks Free Library is sponsoring all the summer programs, with programs available almost daily for kids. The schedule is available at the library and on the library’s website, brooksfreelibrary.org

- F. Ms. Sally Urbano said that she wanted to make a quick comment as a follow up to what Mr. Duncan Barry discussed earlier on the DRI referral. She said that Mr. Jonathan Idman, Cape Cod Commission, did appear before the Planning Board and shared information to them about this referral. She said the Planning Board does

have it under consideration, and they are being very thoughtful about it. However, it will be a collaborative effort, because if the Planning Board does vote yes, then it will come back to the Board of Selectmen. At the last Planning Board meeting there were over 50 letters, and that many people in attendance, urging the Town to help with this referral. She would urge them to consider this.

CONSENT AGENDA

- A. Vote to approve 2019 Annual Miscellaneous Re-Appointments
- B. Vote to approve the recommendation of the Assistant Town Administrator to approve the installation of approximately 37' (feet) conduit and one handhole#506/H6A in town road to customer at 36 Huckleberry Path, Harwich
- C. Vote to approve the recommendation of the Town Administrator for the promotion and appointment of Carlene Jones to the position of Assistant Assessor
- D. Vote to approve the proposed Visiting Nurse Association FY20 contract - \$4,000

Mr. Ford moved approve items A through D, listed above, and noted that this does not include E. Seconded by Mr. MacAskill.

Mr. Lincoln Hooper, Director, Department of Public Works, said that under item A, he would like to recommend that the appointment of Chris Nickerson be changed to Griffin Ryder as the alternate to the JTC.

Mr. Ford moved to approve the 2019 Annual Miscellaneous Re-Appointments with one change: Cape Cod Joint Transportation Committee alternate representative no longer being Chris Nickerson, now being Griffin Ryder. Seconded by Mr. MacAskill.

All in favor, motion carried by unanimous vote.

E. Procedure on the release of certain Executive Session Minutes—Second Reading

Mr. Howell said he had asked to split out item E, because it is a second reading for policy change and he does not think it belongs in consent agenda. He said that perhaps they could walk through the change language from last time.

Mr. Powers said that in consultation with the Town Administrator leadership of the Board, what he has articulated the procedure in the memo that is part of the packet. Following an executive session, a draft of the minutes for that session will be placed

in the confidential folder and available for review by the members for a week. If any member has concern or objection, they notify staff.

Mr. Ballantine said he insisted on the deadline, for one week, so that it did not hang on forever.

Mr. Howell moved that the revised procedure for the release of certain Executive Session Minutes be approved. Seconded by Mr. MacAskill.

All in favor, motion carried by unanimous vote.

NEW BUSINESS

A. 5 year Recertification of Participation in the Community Rating (CRS) System Program:

Ms. Charleen Greenhalgh, Town Planner, provided an explanation for the CRS. She explained that Harwich has been participating in this program for 25 years and is currently designated as a Class 8 under the CRS. This allows for a 10% discount for those in need of flood insurance, which is an approximate savings of \$69,000 for policy holders. It is looking like this year, thanks to the valiant efforts of staff, specifically, Elaine Banta, Planning Assistant and Shannon Hulst Jarbeau, who is with the County and assists community with the flood insurance. They worked tirelessly to get the information and the paperwork needed to participate in this. Also, Amy Usowski, Conservation Agent, Nikki Smith, Assistant Conservation Agent, Shelagh Delaney, Executive Assistant, Ken Murphy and Ray Chesley, Building Commissioner.

Ms. Greenhalgh said that this year they will be able to move to a Class 7, which is really huge because there is only one other community on the Cape in that class. This would afford a 15% discount, which works out to approximately \$98,000 annual total saving's, or \$333 per policy annually.

She explained that to participate in the CRS, this is something they do every day, not just every 5 years. They provide information through various sources and they are constantly providing information to people about being in flood plains, and what that would mean. This is a daily thing and they do need to recertify every year, although this year is their five year recertification.

Ms. Greenhalgh said that she has provided three documents, form CC-230, the CRS program data table, and the third is a letter of protection for open space in the flood zone. She requested that the Board approve her recommendations.

1. BOS vote to authorize the Chair to sign a letter regarding wetland and flood plain land under its jurisdiction

Mr. MacAskill moved to authorize the Chair to sign a letter regarding wetland and flood plain land under its jurisdiction, as presented. Seconded by Mr. Howell.

Mr. Ballantine said this is a great job and great example of a service to help a lot of people. Ms. Greenhalgh said that the Town is actually eligible for Class 6, but something at the state-level is preventing any communities within Massachusetts from qualifying for a Class 6.

All in favor, motion carried by unanimous vote.

2. BOS to vote to authorize the Chair to sign the required Verification Letter for the CRS Recertification

Mr. MacAskill moved to authorize the Chair to sign the required Verification Letter for the CRS Recertification, as presented. Seconded by Mr. Howell. All in favor, motion carried by unanimous vote.

3. BOS vote to authorize the Chair to sign the letter for Protection of Open Space in Flood Zones

Mr. MacAskill moved to authorize the Chair to sign the letter for Protection of Open Space in Flood Zones. Seconded by Mr. Howell. All in favor, motion carried by unanimous vote.

B. Road Maintenance revisit due to failed funding—Chapter 90 only

Mr. Christopher Clark, Town Administrator, provided an overview and said that they had intended at Town Meeting to have two articles for consideration. They had one to redo Lower County Road, which failed. They were trying to offset some of the Lower County Road work, and they put it into the road maintenance program. \$700,000 out of the \$1.4 million, of that program, would go to offset some of the work on Lower County Road. He said that they put that in for bonding reasons, and

he thinks some people at the ballot thought that was another way to do the project. It was not, it was just a way to supplement. However, it got voted down. So, what that means for the Town, is that we are now left with an allocation of just under \$700,000 from Chapter 90, in which we would have to do the roadways in the community, as opposed to \$1.4 million. Mr. Clark said that he was asked to meet with Mr. Hooper and put together a plan for what they can do to address this. Mr. Hooper is here to walk through the ramifications and what they will and won't be able to do, as they move forward for FY20.

Mr. Hooper explained that he was asked by Mr. Clark, from a meeting that he had requested, to come in and discuss these subjects and answer the questions to the Board about the failed \$700,000 article, the road maintenance article, and what is the plan for Lower County Road.

He has been quite surprised by the number of inquiries he had about the impact of road maintenance program and not having local income for the first time in 16 years. He said that their road are in good condition and they have had an aggressive road maintenance program supported by the various Boards of Selectmen the various committees. This is the first time in 16 years, since he had been Director, that they do not have local money. The impact is not very much for this year and maybe an additional year. However, at some point, there is a time that you go from maintenance model to a reconstruction model, as is the case with Lower County Road. That becomes more expense, rather than attacking it maintenance first. He added, that he believes they have only reconstructed two roads in twenty years. He thinks there is not a lot of negative impact for one year.

Mr. Hooper said that they get just shy of \$700,000 a year in Chapter 90 money and have done pretty steadily from the State. Chapter 90 money is our gas tax coming back to the Town and is a process that we seek the Boards approval and they get reimbursed by the Department of Transportation (DOT) for that work.

Mr. Hooper explained that given the failure of the \$700,000 road maintenance article at the ballot and the fact that the DOT had not released Harwich's apportionment of Chapter 90 until this week, he had to cancel two previous Chapter 90 projects that the Board had approved. If he had not cancelled them, there would have been no money for unforeseen circumstances.

He said that now that they have released it, they have approximately \$1.3 million Chapter 90 funds available. Mr. Hooper said that he would like to take the five year road maintenance document, and move that all out to one single year, to continue the road maintenance. Part of that request was to do Depot Road in South Harwich,

to put drainage in. Doing this will allow them to stay ahead of the gas company. He has a Chapter 90 project request with him, to replace the one they were doing on Great Western Road. He explained that the urgency is because of the contract with Robert Our Company which will be expiring sometime in August, and has very favorable rates. He will have to re-bid the contract, which will end up costing more in the future. Mr. Hooper said that he has documents that are ready for signature, if they are willing to consider it. Right now they have no Chapter 90 projects requests in the queue.

Mr. Ballantine asked if he could summarize the dollar amount. Mr. Hooper said \$173,500.

Mr. Clark said that the two projects which were withdrawn are the chipseal for the various roads for \$331,000, and the Great Western Road drainage for \$302,000.

Mr. Hooper repeated that his request is for \$173,500, which is less and the urgency is because of the contract.

Mr. Howell explained that it does not help for why they are there now, but he said they need to do a better job writing the ballot language. He knows it was confusing, but there was not anyone that said how to write it. It was a self-inflicted wound, this is something that we get money back from the State, which we are not going to get. This is a serious problem

Mr. Ford thinks it would incumbent on them, as the Board of Selectmen, to be able to articulate that and help people understand. He agreed that it should have been written differently, but it is on them to help the voters understand.

Mr. MacAskill said that he imagined the contract that Mr. Hooper has should be handed over to the Town Administrator to put on the agenda for next week, since it is not on the agenda, they cannot vote tonight. Mr. Ballantine said the agenda is broad enough that they could consider it.

Mr. Clark asked to clarify that the item is in the packet under FY20 and listed as Depot Road drainage prior to National Grid re-pave for \$230,000. He also wanted to follow up on the discussion and said he worked together with bond counsel to put together the language of the ballot question and they did not have in the maintenance program the work on Lower County Road. If he had put Lower County and had no reference in the maintenance plan, they would have had problems with counsel.

Mr. Hooper said his urgency is about working with the Robert Our company who is able to do it before their current contract expires.

Mr. McManus moved to approve the Chapter 90 submission as presented by the Director of the Department of Public Works. Mr. Clark clarified that this was to approve the proposed road maintenance program in the amount of \$173,500 for drainage work on Depot Road, South Harwich.

Mr. Ford asked to clarify if the request was for \$173,000 or \$230,000 and it was explained that the original estimate was for \$230,000 but the actual quote is for \$173,000.

Motion carried by a vote of 4-0-1, with Mr. MacAskill opposed.

Mr. Hooper further discussed the plans for Lower County Road. He said that they had a meeting with Mr. Clark, Chris Nickerson, Road Manager, Griffin Ryder, Town Engineer, and Dan Pelletier the Water Superintendent. He said they have approximately \$150,000 worth of patching, which will need to get done before winter. If this is bid as a separate project, it may cost less by approximately 30%. The second part would be crack sealing after the patching is done and then comes the larger question. They could chipseal the road and get about seven years out of it, for about \$100,000 and get some time. They could do that with 20% rubber and it would come out ok. The other option is to rebid the project and bring it to the voters and hopefully with a different outcome. He still thinks the right thing is to do the project. In round numbers out of the \$4 million project, they have 1 million in fixing the sidewalk, there is not an inch of that side walk that is ADA compliant, there is \$1 million in the ground in drainage. He defers to the Board in what their pleasure is. He had some of his counterparts with him tonight and introduced them along with their qualifications: Griffin Ryder, Town Engineer, Tommy Ockerbloom, Civil Engineer, Chris Nickers, Road Manager.

Mr. MacAskill asked if they were expected to discuss bring this back?

Mr. Clark explained that they were looking for direction. There are two options, one is to delay a year or two and go back out, or they can either chipseal and hold the road together until such time they need to do more major work. They would like to get a sense from the Board.

Mr. MacAskill asked for an explanation on the two projects that were pulled due to the failed funding, when there were voted on after the failed funding. Mr. Hooper said that it was two reasons, the failed funding and the fact that the Mass DOT had not released the apportionment until last week. He said that if they had done those projects, that would have been all the money they had.

Mr. MacAskill also asked about the \$120,000 in Water Department responsibility and if that had been voted on by the Water Commissioners yet?

Mr. Clark said that the Water Department did the work on that project, and had \$60,000 left. They have asked them to hold those funds, and use that toward the Lower County project.

Mr. Hooper said that since some of the responsibility is on him, they had agreed to split the cost with the Water Department, which they think it is the right thing to do.

Mr. MacAskill said when this project came out, before it got rejected at Town Meeting, they were going to spend \$1,000,000 of their Chapter 90 money on Lower County. He would like to know why they are now only looking at spending \$150,000 and why they would not work on some of the drainage? He asked if he was missing something.

Mr. Hooper said that they have the proposed road maintenance plan for FY20 in the packet which totals \$1,295,589.00. That is all Chapter 90 money and that is what they propose to do.

Mr. MacAskill asked about Lower County Road and what money is he planning to spend there? Mr. Hooper said right now they will go and do the patch work for the \$120,000.

Mr. MacAskill asked why they were talking about spending \$1,000,000 out of the Chapter 90 funds then, but now nothing on drainage or anything else?

Mr. Hooper said as the project developed, the Board seemed like they wanted to lower the impact to tax payers, so he put the brakes on all their spending last Spring. If the project had gone forward it would have been 4m bid, half million in police detail .. million in chapter 90 .. that was the plan. He does not think piecemealing this road is a good idea. They should patch it and decide if they want to take another try at it or just chipseal the road.

Mr. MacAskill said his argument is that he thinks it would be wrong of the Board to assume they could bring it back, and have it approved at Town Meeting. He thinks they should try and fix some of the drains and fix some of the shambles and get more of that road done.

Mr. Hooper said that when the repair a road they do it all at once; the drainage, the sidewalks, overlay or mill and fill, guard rails, signage. They have never piecemealed something together and he thinks there are economy of scales and it is better to do the project or don't do the project. He said that the reason this road got to where it is was because they had a Transportation Improvement Program that they were trying to follow. This was the next road in the queue but did not happen after Route 124 fell apart.

Mr. MacAskill said that he knows the history and he would still like to know what can be done now and how they can move forward?

Mr. Clark further explained why they are doing it this way and the need to keep some funds on a contingency basis.

Mr. Ballantine asked Mr. Hooper what the urgency is for the discussion tonight on this? Mr. Hooper said none, except that they need to do some patching. Mr. Ballantine would like to have him bring this back because whatever their decision is, they will need to have to explain it at Town Meeting next Spring.

The Board continued their debate on this. Mr. Ford said the reality is at some point this road will have to be done. Mr. Howell said the Finance Committee is set up to disperse money should an emergency occur, and he would think they could look at this and there could be some money available.

Mr. Ballantine said they have had a good discussion and he thinks they need to bring it back.

CONTRACTS

- A. Award bid for Town of Harwich Fire Station #2 Security System Bid to Galaxy Integrated Technologies, Inc. and sign agreement document

Mr. MacAskill moved to award the bid for Town of Harwich Fire State #2 Security System Bid to Galaxy Integrated Technologies, Inc. and sign agreement document in the amount of \$85,000. Seconded by Mr. Howell.

Mr. MacAskill said he wanted to acknowledge and thank Lieutenant Scott Tyldesly for all the work he did on this.

Mr. Howell wanted to go little further and say that this is exactly what he has been looking for in regards to the summary. It had all the information.

All in favor, motion carried by unanimous vote.

OLD BUSINESS

A. Phase 2 Sewer and Sewer Pump Station Easements: Execution of Order of Taking; and Acquisition of Sewer and Drainage Easements in Public Ways: Execution of Order of Taking

Mr. Clark clarified some concerns from the Town Clerk regarding the public way. He said that basically the public ways were recorded at the Registry of Deeds, but they did not have them on file downstairs. When the Town Attorney did her due diligence, she was able to provide the book and page numbers to the Clerk's office. He said that the other piece that came up, was that some of the roadways were so old that there were no book and page numbers for them. They were county roads that the Town has historically maintained. The attorney drafted a letter stating that they have been maintained by the Town. He continued that it is really important to have the project go forward and the Town needs to have possession of all the land, in which the system is going to be constructed.

Mr. Clark said that what is before them this evening, is the Order of Taking, for all of the pump station locations. There are two cross country runs; one that goes in front of Stop & Shop and the other behind the Four Hundred East Plaza, and the other one was the public vs. private ways. He said that the private ways is for sewer only. Mr. Clark explained that the Board of Selectmen can take this action, because they do not have a formal sewer commission. So, in this case they would be acting as the sewer authority. The request is to approve the Order of Taking, which has been signed off on and attested to, so they can move forward with the State Resolving Loan Fund (SRF).

Mr. Ballantine asked if they were only concerned with the sewers. Mr. Clark said legally the only thing they can do is in regards to sewers, anything else would have to go to Town Meeting.

Mr. McManus moved to approve the Order of Taking with the Board of Selectmen, acting as the Sewer Commission, for the various easements as detailed in the Order of Taking, as presented by the Town Attorney. Mr. Ford seconded the motion.

Mr. MacAskill said that he had a question on page of the packet, titled; *Addendum A To Certificate Of Counsel As To Title To Project Site*. He said that items B and C show no dates. Mr. Clark said that they can type in the dates, as today's date.

Mr. MacAskill also asked why Mr. Clark was the one to certify the roads vs. the Town Clerk? Mr. Clark said that it was because she did not have any records, the county records were not in their possession and the other roads were too old.

Mr. MacAskill said that he wanted to mention that they are getting all of this last minute. He said that Ms. Julie Kavanagh, former Chair, had brought this up no less than six times; that they had to take care of the easements and right of ways. He said that on Wednesday, the 5th, it was handed to the Clerk to certify for Monday, the 10th, and extended to the 17th. Mr. MacAskill said that he had spoken with Mr. David Young, CDM Smith, and Mr. Young had said that his part in this was because he was going based on Assessors records, and assuming they were correct. This was a reasonable answer to him. Mr. MacAskill said that his displeasure is that there is a huge lack of communication, and again the board is doing this last minute, that they should not be doing last minute.

Mr. Clark said that he was told, by both KP Law and CDM Smith, that in most cases there is a register of town owned roads, and the Clerk would just certify something that had already been certified. He said that Ms. Anita Doucette, Town Clerk, did her due diligence, and when there was an issue she just did not sign it. He explained that it did mean there was more of a process to it and they will need to do something internally to ensure if it is a public way, it is on file with the Town Clerk.

Mr. Howell said that this is not as easy an answer, as what you just heard. There were five people who worked on this, but only given a week and they have to make an action by June 30th. He said of the five people, there were three Department Heads, the Town Clerk, the Town Engineer, the Deputy Assessor and two professional staff. None of them could come up with certifying it. He also made note of what Mr. Clark was certifying personally, and questioned how he could make an attestation to it, since he has not been there for 20 years.

Mr. Clark responded that he has been Town Administrator for six years, and before he made a certification as an administrative officer of the organization, he asked Mr. Hooper, and others in the community, about how long the town has been maintaining the roads to make sure he could attest that the town has maintained these roadways for 20 years. He has not been here for 20 years, but he did seek out the information from folks that have been here for that period of time. He would certainly not attest to something that was not accurate in the execution of his job.

Mr. Ford clarified that typically this would be a simple process. This is more of an unusual situation and the Town should be able to certify this rather quickly. He said that the timing of this, if it were described as a normal course of events, the timing of Mr. Clark requesting to the Clerk's office would not have been unusual. Mr. Clark agreed.

The motion presented by Mr. McManus carried by a vote of 3-0-2, with Mr. MacAskill and Mr. Howell voting against.

Mr. MacAskill added an additional comment, that the County does not own roads and said that they should do one final taking of all county roads at Town Meeting. Mr. Ballantine said they will bring that back to have a further discussion.

B. Bid award Robert B. Our contract - \$11,368,663.48

MOTION: Authorize the Town Administrator to execute the Phase 2 Contract 1 CWSRF4424/1 to the Robert B. Our Company in the amount of \$11,368,663.48

Mr. Clark explained that they have representatives from Weston & Sampson and CDM Smith available to discuss strategies about this amount and going forward. The purpose of tonight is to do the contract award for Robert B. Our Company in the amount of \$11,368,663.48, as authorized in phase 2 of contract 1 CWSRF4424/1.

Mr. McManus moved to award the bid to Robert B. Our the contract of \$11,368,663.48 and authorize the Town Administrator to execute the Phase 2 Contract 1 CWSRF4424/1 to the Robert B. Our Company in the amount of \$11,368,663.48. Mr. MacAskill seconded the motion.

Mr. Francis Yanuskiewicz, Weston & Sampson, said that they have been retained to assist and help make sure the transition to construction goes smoothly. What they did talk about at the kick off meeting a couple of weeks ago is the bid process and they are seeing that the competition is not as fierce as it once was. He did take a

look at their bids, and they are looking at about a 3% differential between the three bidders. So, that is the price, that is the going rate. He did note that Robert B. Our offers savings due to being local, and that they did not include mobilization. Just to attest these are the prices, and they are going up significantly in the Commonwealth right now.

Mr. Ford said he appreciates what he said and prices increasing, however, the quote coming in 33% higher than expected is a big increase. He asked if Mr. Yanuskiewicz was comfortable with that.

Mr. Yanuskiewicz said that it is a little bit high, but he does not know what the basis of the design of the project was. He has had projects that have had increased by as much as 20%.

Mr. Ford asked if they would be able to provide assistance in the future, for these things. Mr. Yanuskiewicz said yes, if they are requested to.

Mr. MacAskill voiced concern about the quote being \$3 million higher and he asked CDM Smith the same question. He said that when he spoke to the contractors, he was told they all bid roughly the same amount, so he is trying to understand why they have a \$3.5 million increase. He said if the contractors knew what the price would be, why didn't CDM Smith and the estimators know? Mr. MacAskill said if this is the way our program and our comprehensive wastewater management plan is going, then we really need to do something different. They did go from \$240 million to \$300 million because of some inflation, from when they passed the plan, and now they are going up to \$3.5 million on one part of their phase. He said that they owe it to the tax payers to come in closer than this. He wants to understand what changed other than the market?

Mr. David Young introduced himself and Mr. Michael Giudice, both with CDM Smith. He said that they were there to continue on with the discussion they had last week and he would be happy to try and answer the question again. They are all under the same credibility and scrutiny of that issue. He explained that the estimate that they had, at the 50% conceptual stage, was a number for their capital plan and getting ready for Town Meeting. That was \$8.5 million, and their bids came in at \$11.3 million. He said that they tried to explain this last week, they look at it in three components: pipe, pumping stations and paving. Mr. Young said that if you look at that, 42% of the cost of the increase is in the paving, the other two are split pretty equal; 29% in pumping stations and the remaining 29% is in the piping and other miscellaneous. He said that there was not a specific item in there, other than

the paving which appears to be up 50% and that is what accounted for \$1.2 million of the increase.

Mr. MacAskill said that they had assured them they could feel safe going to Town Meeting and these price increases really make them feel foolish going back to Town Meeting.

Mr. Young said no one feels that more than they do. When they said that, they meant it. Unfortunately, they stumbled out of the blocks on this one. It is just the type of work that is happening

Mr. Ford said he understands and they feel the same way. He said that they are not trying to be adversarial here. They are trying to represent this Town in a way that they are trying to truly represent the budget. He said that Mr. MacAskill is right and it is really tough to have a Town Meeting that they had this year, with a lot of justified scrutiny, and have this come on the heels of it. It is there responsibility to give everyone the best picture of the costs. If there is a way to get a more frequent interaction relative to the cost, then that might allow them to be more prepared and prepare the tax payers.

Mr. Ballantine said that this is definitely a lesson learned, and they should not go to Town meeting without 90%, as opposed to a 50%. They should slow the process down.

Mr. Giudice said that it is a possibility, and they would have to look at the timing, especially for communities participating with the SR program.

Mr. Young said that Mr. Giudice and his team are updating the remaining work using those unit costs, that they just received. Also, the database that they had been using, just to make sure they are using the absolute latest cost available.

Mr. McManus asked about the \$24 million that was voted on a year ago, and approved for the construction budget that we have to work with was set 15 months before we opened the bid. So, it would have been nice to do estimate updates along the way. If the estimates show increasing there is not much you can do about it, because you have already voted the amounts. The other option would have been to hold on to it until you have 100% design package and not vote on it until you have a bid in hand.

Mr. Howell said that he totally agrees with what Mr. McManus just said. He said this has been very collegial and he appreciates that, but it's not individual it is the

Town of Harwich, it is a municipality. He said that these estimates are way off. Even if they used the constant percentage that was talked about, that only gives 12% in two years. This was done in March, two years ago, and it is the very poster child for everything that goes wrong, when you don't go to Town Meeting to ask for approval. He said the fire department was every example of how to do it.

He that he cannot support anything right now unless he can be assured they will get everything done. Mr. Howell read the explanation that was presented at town meeting and voted on:

Explanation: Phase 2 of our Comprehensive Wastewater Management Plan requires design and construction of a Watershed Collection System. In FY18, the design dollars and our Intermunicipal Agreement with Chatham were funded. The FY19 request includes the actual construction costs of the collection system also including the tie-in costs with Chatham in their pump station and piping to their treatment facility. This will fully implement Phase 2 of our regulatory required plan.

Mr. Howell does not see how they can go back to Town Meeting and say they awarded the first half of this, but we can't get it done. This is not that things happen. This is what Town Meeting was given as an estimate, and they were told this finishes everything. If they have to go back and ask for more, it will be disingenuous and then who is going to believe them in the future.

Mr. Clark said he is unhappy that they did not hit the targets. He explained that they had done a 50% design estimate and they did make some design changes to make things better for residents. He also said that things do change, and they need to realize they are subject to market forces, and the market forces in this case have been unfavorable. It is there intent to go out for contract 2, get done what they can, and maximize the zero interest, and put together a contract 3 for what is left.

Mr. Howell asked for reassurance that everything will get done. Mr. Clark said he cannot be held to account for how the economy is doing or be able to predict the future. The intent is to do the full scope of the project, it did not come in the way they wanted it to.

Mr. Howell also commented on how short of a time the contract was out to bid.

Mr. McManus said he remembers that they needed to rush due to the need for SRF funding.

Mr. Ballantine said that his frustration is that CDM fell behind in the whole process, by two to three months. He said that there may be reasons for that, but he does want to be sure going forward, that they have the proper resources to move it as quick as they can.

Mr. Young said that they were right on schedule when they submitted to DEP, then they hit some delays going forward. He explained the process and timing with the SRF funding, and that staffing was not an issue. He repeated, as Mr. Clark had said, the process for moving forward is to put out contract 2, within the next few weeks. They had to redesign the pumping station, to a suction lift pumping station, at their request. That is almost complete, and has been submitted to DEP and they hoping to get the final comments from them soon. Mr. Young said that they have about \$6.2 million remaining for a contract to be awarded and they are allowing for the 5% contingency which the DEP requires in SRF projects to be held. So, they would be committing about \$12 million, which includes the bid price, plus the 5% contingency. That leaves \$6.5 million, take out the 5% and that gives you the \$6.2 million that they can award. Then anything that is not put in there, they would go out for a third contract. They could take that to a Special Town Meeting in the Fall.

Mr. MacAskill thanked Mr. Young for the explanation, and commented on the article that Mr. Howell read. He said that perhaps they should be more cautious on how they word articles. He said that he has been contacted by many people who urged him to vote no, but explained that he can't, because of the SRF funding. He said, people need to realize that they may be \$3.5 million up on the bid, but they are saving nearly \$15 million in the zero percent interest.

Mr. Howell said that he needed to explain why he won't vote for it. He said at some point someone is going to be held responsible. It is Town Meeting, it is not my money or their money. He said that they asked Town Meeting for \$24 million and they said it would fully implement phase 2. They don't have enough money to finish this project, and if it was anything else they would not be allowed to go forward until they secured the full amount of the bonding.

Mr. MacAskill said that he respects that, but it may end up costing more money if they delay it. They are not doing it because they want to, it is because they have to. They will have to go back to Town Meeting and explain their decisions.

The motion carried by a vote of 4-0-1, with Mr. Howell opposed.

C. Review of Town Meeting Actions—Pass/Fail

Mr. Ballantine said he asked for this to be on the agenda to see if there were items that they would want to bring up for discussion going forward. Mr. Ballantine said that they can email it to him and they can bring it back for discussion. He also mentioned that they will need to bring back for discussion again is the Pet Cemetery.

TOWN ADMINISTRATOR'S REPORTS

Mr. Clark reported that he attended the CPC meeting last week. They had an open session about what the needs of the community was. He tried to provide an overview of some of their projects, including recreation, historic, open space and housing. He said they seemed receptive.

Mr. Clark also attended the Finance Committee meeting and had to cover the Recreation Director that could not be there, to discuss going from the \$175,000 to \$200,000 that the Board had approved. The Finance Committee did vote and approved it, for the after school program. He said that the Finance Committee had also mentioned doing a follow up to Town Meeting to discuss about how Town Meeting can flow a little better. He suggested that perhaps they could do a finance book, to provide a listing of all the debt and debt impacts. They may look at that internally and put something together.

Also on the good news front, Mr. Clark announced that the Cultural Council received a \$5,000 grant. He said that this was thanks to the efforts of Ms. Cyndi Williams, Executive Director, Harwich Chamber of Commerce and Ms. Charleen Greenhalgh, Town Planner. This will be used to do some work at the Cultural Center.

Mr. Clark said also thanks to the efforts of Ms. Greenhalgh, they also received a grant for \$20,000 as part of the Municipality Vulnerability Preparedness Program.

He also wanted to let them know that the Safe Routes to School program, and the contractor with AECOM, will be meeting tomorrow from 2:00 pm to 4:00 pm. They will be meeting at the Elementary School if any of the Selectmen would like to join them.

SELECTMEN'S REPORTS

No reports.

ADJOURNMENT

Mr. McManus moved to adjourn at 8:28 pm. Seconded by Mr. Howell. All in favor, motion carried by unanimous vote.

Respectfully submitted,

Lisa Schwab
Board Secretary

**MINUTES
SELECTMEN'S MEETING
GRIFFIN ROOM, TOWN HALL
MONDAY, JUNE 24, 2019
6:30 P.M.**

SELECTMEN PRESENT: Ballantine, Ford, Howell, MacAskill, and McManus

OTHERS PRESENT: Town Administrator Christopher Clark, Fire Chief Norm Clarke, Carolyn Carey, Judith Ford, Mary Oldach, Griffin Ryder, and others.

CALL TO ORDER

Mr. Ballantine opened the meeting at 6:30 pm, and called to order the Board of Selectmen.

WEEKLY BRIEFING

- A. Chief Norm Clarke, Harwich Fire Department, said that he has an example of our State Government and local government working together to take care of its residents that we all serve. He was notified on Friday, that they received a payment for \$125,499. This is from a program with MassHealth that they enrolled in, and it is used to help offset some of their billing.

- B. Ms. Carolyn Carey, Director of the Community Center, said that she wanted to remind people that they still have opportunities for vendors at the Seaside Marketplace, which will be opening July 3rd. If anyone is interested in sharing their wares, they are looking for vendors and applications can be found online, at the Cultural Center, or they can contact her.

Ms. Carey also wanted to remind people that the fiscal year begins July 1st, so membership renewals for the weight room at the Community Center will be due. She said that she also wanted to let people in the community know that they can sign up for the Community Yard Sale, which will be at Brook's Park on August 3rd. They already have 15 people signed up. If it is a nice day they will have unlimited space, but if not, and they have to go inside, space will be

limited. This is done to allow clubs and organizations to pay for rooms at the Community Center.

PUBLIC COMMENTS/ANNOUNCEMENTS

A. Ms. Judith Ford, President, Friends of the South Harwich Meetinghouse, said that they had a phenomenal award ceremony in Boston at the Mass Historic Commission. They recognized the South Harwich meetinghouse project. She wanted to publicly announce and recognize the efforts that have been given by Town Administrators, Board of Selectmen, Building Inspectors, and staff from every department, to get the project to this point. She wanted to say how much they appreciate it and what a great honor it is for their organization and for the Town of Harwich. She will be putting a board up around town to let people know about this project. Ms. Ford also announced that in the middle of July, they hope to have a full year of programming ready for the Meeting House.

Mr. Ballantine also mentioned that there was an article, in today's Cape Cod Times, that had a very good write-up.

CONSENT AGENDA

- A. Accept a gift of \$400.00 from the Harwich Cranberry Festival for the purpose of paying for the tuning of the piano recently donated to the Cultural Center
- B. Vote to approve 2019 Annual Committee Re-Appointments
- C. Vote to re-appoint Jim Joyce to the Planning Board—term to expire June 2020
- D. Per the recommendation of the interview nomination sub-committee—vote to appoint Sharon Fleger as a Full Member to the Board of Health
- E. Vote to affirm appointment of Dana DeCosta as a Board Secretary
- F. Vote to Exempt Dana DeCosta from the provisions of MGL, c.268A, §20

Mr. Ballantine said that he would like to hold items E and F, above, for procedural reasons and it will be added as an agenda item in a couple of weeks.

Mr. Ford moved to approve Items A through D, as listed above. Seconded by Mr. MacAskill.

Mr. Howell said that they had received a revised list for the reappointments, which was not part of their packet. He included the following changes;

Brendan Lowney, 2022, Kim Bourgea, as the Housing Authority Rep, for the Community Preservation Committee, for a term ending June 30, 2020, and deleting John Preston from that list. Also, the appointment of Sharon Pflieger, for the Board of Health, would be through June 30, 2022.

Mr. Ballantine also noted that instead of John Preston, they need to substitute Ms. Elaine Shovlin, because her term expires at the end of the month, and she should be reappointed.

Mr. McManus said that he needed to recuse himself for item A, and Mr. Howell said he needed to recuse himself for the appointments.

The motion was accepted as revised, and seconded by Mr. MacAskill. Motion passed at a vote of 3-0-2, with Mr. McManus and Mr. Howell abstaining.

PUBLIC HEARINGS/PRESENTATIONS

A. Safe Routes to Schools Update; Mary Oldach, Principal, M.Ed. Harwich Elementary School and Griffin Ryder, Town of Harwich Engineer

Ms. Mary Oldach, Principal, Harwich Elementary School, said that she is there tonight with Mr. Griffin Ryder, Town Engineer, to give an update on the Safe Routes to Schools and about the sidewalk grant that they received. Ms. Oldach said she wanted to first give some background on the program and Harwich Elementary School's involvement with the program. Safe Routes to Schools is a program through the Mass DOT and encourages schools to promote walking, riding bikes and pedestrian access to the school facilities. They began to participate in this program when practicing their crisis drills with the students and the evacuation of the building. She said that because of the involvement in this program they achieved a gold level status with the Mass DOT and also they had a strong application because of that and they have about 40% of their students are on free/reduced lunch. The application came to their attention back in December, and it was a combined application with Harwich Elementary School and the Town of Harwich. They had looked at the improvement of the crisis route for the students. She said on any given school day, they can have around 700 people in their building, with about 560 being students. The crisis route is down primary sidewalks and what they have noticed is that the sidewalks are certainly not ADA compliant. They also put in their application

improvements to the Town recreation facility connecting to the bike routes and to Brooks Free Library and park as well.

Ms. Oldach said that they did have a kick off meeting with Mass DOT and Cape Cod Commission, Fire Department, Police Department and the school, just last week and Mr. Ryder will update on the progress.

Mr. Ryder provided an update on where the project is now and next steps moving forward. He said that the map shows the limits of the project, which are South Street to the west, Main Street to the north and then Sisson Road to the East and South East. One of the connections we also want to evaluate as part of this process, is the stretch from Sisson and Parallel Street to Bank Street, where the Library is. Mr. Ryder said that Ms. Oldach did a great job in applying for this grant and getting awarded nearly \$600,000. He said this is a new process for the Mass DOT and basically the intent of the process is that there are 14 projects that were awarded a Safe Routes to School grant, which totaled \$15 million. They are basically looking to spend \$1,000,000 on each of those projects and it includes, design, construction, but it does not include right of way acquisitions. This grant will allow them to design and know where right of ways might be. This program gives you money to get the designs figured out, work with DOT and then also get the construction to get it built. The earliest the project would be carried out would be 2022 to 2024. He further explained the next steps in the process are to file a couple of project notification forms, which are due at the end of the week. The submittals are shooting to a deadline of Aug 15th which is when the Mass DOT Project Review Committee (PRC) will meet and decide to move projects forward, or not. He said that then by July 31st, they will need to do a project information form, which will include conceptual project designs, which is being done by AECComm, an engineering firm that was contracted by Mass DOT. That will get them to a pre-PRC meeting on Aug 1st then to the PRC meeting on August 15th.

Mr. Clark said that he attended the meeting and they walked the entire route. He said explained the benefit of completing a DOT project more timely in order to get more funding for the project. He said they are in good shape with being in the first third with getting things submitted.

Mr. Clark said that the bad news that they had indicated, was that they are not sure how they want to deal with *complete streets*. This means that they would ask for sidewalks on both sides of the street and a bike lane. He thinks it is a good opportunity to improve sidewalks on one side, but it does not lend itself

to both sides. There are some approaches that they can take for prioritization, to perhaps come up South Street and Main Street and have that be Route A, and have Route B come up Sisson. Mr. Clark said one thing he was hoping to get for the Board is to get to more of a final design, because as they have heard, it is a very tight timelines. As part of the process is they will come back on 25% to 75% complete submittal. They will have a public meeting to walk people through that and explain that it is the Town's intent to improve the sidewalk on one side and lay out a case for a project exception.

Mr. Howell said he thinks this is great, and that it will be a real plus if this will happen. However, he is thinking of how things happened on Route 137 and Route 124, and wanted to know if they cannot move forward with the complete streets, and cannot get the exception, would they owe the State anything for the endeavor?

Mr. Clark said the easy answer is no. AECComm has been contracted with to do the initial design, so there is no cost to the Town. He said that they did ask if there were other towns that would be able to comply with the complete streets, and the answer was no. They have 15 communities submitting and they understand that not all of them will be able to comply with that. He would hate to lose the money and they need to concerns that they have.

Mr. Ballantine commented on how important it is for the safety of the kids and that they will have to have their ducks in a row.

Mr. Ryder said personally he thinks that the DOT will look at this a little bit differently, because if it comes to a point if complete streets means non-safe route to school, it won't look good. He also confirmed that a public hearing would happen around the 25% of the design. He will also bring updates back to the Board at each submission process.

NEW BUSINESS

- A. Request from the Harwich Cranberry Festival for a partial waiver of the facilities fee for the courtyard rental for Thursday night concerts at the Cultural Center; from \$1,050.00 to \$525.00

Mr. McManus recused himself from this discussion.

Mr. MacAskill asked about the number of concerts and how many Cultural Center staff would be needed. Mr. Clark responded that there are seven concerts and Ms. Carey confirmed that only one staff and the cost covers it.

Mr. MacAskill moved to approve the request from the Harwich Cranberry Festival for a partial waiver of the facilities fee for the courtyard rental for Thursday night concerts at the Cultural Center; from \$1,050.00 to \$525.00. Seconded by Mr. Ford. The motion carried at a vote of 4-0-1, with Mr. McManus abstaining.

B. Draft Budget/Warrant timeline—discussion

Mr. Ballantine explained that he wanted to put this on as a draft first, to have some discussion on it, and they will bring it back for a final discussion next meeting.

Mr. McManus said that he took their existing timeline that was mainly driven by the hallmark center in either the bylaws or the Charter for the timing of when things need to happen. He said he looked over last year and remembered them getting to certain points and thinking this is the deadline but it would have been great to see this before and putting times in their calendar for being able to see them, before they have to approve it. He said last year they did not get around to approving and setting goals until late September and that would be better to do the first month of the fiscal year. Also, they have not had on the agenda early on a discussion about what CPC articles they would like to sponsor. They should also look at warrant articles, specific projects or bylaw or charter revisions and have those discussions earlier on in the process. Mr. McManus said that it would be good to have departments present their capital requests, as they are preparing them, for review.

Mr. Ford said that anything that makes them more enlightened and to have a transparent process is a good thing. He also said getting things started earlier in the process, is very good.

Mr. Ballantine suggested that Mr. Ford comment on the work he has been doing. Mr. Ford said that he has spoken with Mr. Ballantine and Mr. Clark in regards to the form that they use for the performance management review for the Town Administrator. He said that he has taken a pass and still working on a new approach. They will distribute it to the Selectmen in the next few days,

for their review and comments. It is just a thought on a different process and the basis he has used is from his years in the corporate world, and using some of things he has learned, to help create a better process. He looks forward to receiving some input from everyone on it.

Mr. Howell said he wanted to put his two cents in, regarding the Charter types of things. He said that in the last few years, they have appeared to have asked the Charter Bylaw Review Committee to do things and then put them in a strange position of claiming that it was their articles. They are articles that they are asking them to help with. He said another thing that is not there, is that they need time to vet it for consistency for structure. There needs to something in there to give them sufficient time to do that.

Mr. Ballantine said that the Chair of the Bylaw Committee was there, and asked if she could comment on the schedule?

Ms. Sandra Hall, Chair, Bylaw Committee, said that it would be good to move schedules up as much as they could, because it did look pretty crunched this past year. They do need time, and she said that they are looking to do a top to bottom review of the charter, to look at the consistency with the bylaws and language etc. Ms. Hall agreed that it is good to have more time and she will look at the timeline to see if more deadlines should be added.

Mr. Howell also said that there is a difference between them wanting to sponsor an article and have the funding source being CPC, as oppose to the CPC having an article. He said that when the CPC submits them, they do not have any control over the warrant. He agrees with Mr. McManus they need to be more proactive.

Mr. Clark said that this past year, they asked the Department Heads to include on their capital forms, what they would be requesting from the CPC, so they could plan. They should be able to do that again this year, and include that as part of the capital process.

Mr. McManus said that his ultimate goal is to come to the point on February 14th, for the article deadline and warrant closes. He said that he always looks at the language in the Charter, and they should be in final form.

Mr. Ford asked about the timing of the articles, and Mr. MacAskill commented about the timeline for the goals. They all agree it is important to have a more effective Town Meeting.

Mr. Clark confirmed that the Board of Selectmen will have a meeting next week, on July 1st, but then no meeting on July 8th, and back on July 15th. Mr. Ballantine said that he will be away for the next meeting, but Mr. Ford will provide the form that he has been working on for review next week, and then they will put it on the agenda for July 15th.

Mr. MacAskill said that he does not know when this meeting happened that decided Mr. Ford would put this draft together, but each board member is going to have individual goal ideas. He asked if there were just going to go with a draft and then tear it apart that night?

Mr. Ballantine said it will be circulated ahead of time for comments, but he raises a good point about wanting an open discussion.

Mr. Ford said that his thought were to get everyone a copy of what the form would look like, with some suggested goals in there, but the goals are not set. The intent would be to contemplate if the structure, make sure it makes sense and ultimately come up with goals they all agree on.

Mr. MacAskill asked if this is coming up, because they are changing the form, and they want the form to reflect the actual goals and objective?

Mr. Ballantine said yes, and he wanted to make sure they agree on what the goals are and then create the form.

Mr. Howell said all of this is great and commendable, but he is concerned about the open meeting laws.

Mr. Ballantine said that everything will be sent through him, and no one will see the others comments.

Mr. MacAskill said that he is concerned about all the private conversations going on, and that this Board has not had any conversations about this process, at all. He said that this conversation about structure, should have been a conversation of the five of them, and done at the table. They need to be a five

member board, that votes as a five member board, and the work happens at the table.

Mr. Ballantine said that they had one meeting, and once they have the structure, they will be able to have a more fruitful discussion and everything will come out to the public.

OLD BUSINESS

A. Phase 2 Sewer—order of taking sewer drainage easements in private ways

Mr. Clark explained that this item is just for a technical correction. He said that when the Board voted last week on an order with a list of the private ways and they did not have the book and page numbers. The attorney recommended that they do an additional order, that specifically identifies the book and page number for each of the private ways. What was distributed in the packet is a clarification on the action that was taken last week and included the book and page numbers on the various private ways. So, they are looking for signatures on that action.

Mr. Howell said that he still believes that the underlying certification is faulty.

Mr. MacAskill asked if they were being asked to vote on something. Mr. Clark said yes, they are voting on the new document. The document they voted on last week did not include the page numbers. They need to vote on this new document, which more specifically identifies the private ways.

Mr. Howell explained that what he said was because some of the address cannot be private ways. He said that some of the addresses are on Route 137, for instance, which would not be a private way.

Mr. Clark said that there may be ones that the mailing address is on Route 137, but they also go down the private way, so they could have ownership interest on the private way.

Mr. MacAskill said that based on the line item, he is not sure what they are doing. They may need to either remove the action taken last week, or a new motion indicating what they are doing.

Mr. Clark said that he will look back through the list. However, the Town Attorney looked at the order of taking, which she prepared last week, and it just gave the listing, but did not clearly state the book and page. He said that this is a clarifying action, to make sure that the ownership of the private ways, is what they are taking.

Mr. MacAskill asked that a more accurate description should be included on the agenda. Mr. Howell said it also would have been helpful to get the legal counsel memo, to know exactly what she was expecting them to do. Mr. MacAskill added that the agenda process, and the Attorney General rules, are very simple. He said that there is nothing on the agenda to let the public know what they are doing.

Mr. Ballantine said that they could postpone this. Mr. Clark said that this needs to be done tonight.

Mr. McManus moved to approve the order of taking prepared in the agenda packet for meeting of June 24th, order of taking of private ways, specifying the book and page citations for those takings on private ways in the phase 2 area. Seconded by Mr. Ford. The motion carried at a vote of 3-2-0, with Mr. MacAskill and Mr. Howell against.

TOWN ADMINISTRATOR'S REPORT

Mr. Clark said that he has engaged in the process for the re-certification for his Procurement Officer status. He has completed a 2-day course and passed the exam. He said that he is halfway done, and he will be taking two additional classes in August. The first will be about prevailing wage, and the second is about real estate transactions.

Mr. Clark announced that the Affordable Housing Trust voted last week to give consideration to two parcels. They did go to Town Meeting, and had several parcels that were deemed to be transferred from the care and custody of the Board of Selectmen to the Trust. The first parcel is Oak Street, closer to the entrance of Cranberry Valley, and second was Sisson Road, next to the Harwich Junior Theater. He said that they engaged the Mass Housing Partnership, to help evaluate those two sites, for development purposes.

Mr. Howell said that they have been taking great pains not to create hostility amongst stakeholders. He said that in terms of the Sisson Road project, they are not talking about taking the one room school building that the junior theater is renting and doing something with that. They are doing something that will supplement that and look for some sort of historic feel. He said that they also spoke with the golf course that what they do will not affect them.

Mr. Clark also wanted to let people know that they have engaged the CDP to run some different programs for training. He wanted to encourage people that have an interest in helping with housing, to look into it. He said that some of the training they have done, has been really exceptional.

SELECTMEN'S REPORT

None presented.

ADJOURNMENT

Mr. MacAskill moved to adjourn at 7:32 pm, Seconded Mr. Howell seconded. All in favor, motion carried by unanimous vote.

Respectfully submitted,

Lisa Schwab
Board Secretary

**MINUTES
SELECTMEN'S MEETING
GRIFFIN ROOM, TOWN HALL
Monday, October 15, 2019
6:30 P.M.**

SELECTMEN PARTICIPATING: Larry Ballantine, Stephan Ford, Donald Howell, Michael MacAskill, Edward McManus.

ALSO PARTICIPATING: Town Administrator Christopher Clark, Assistant Town Administrator Joseph Powers.

Mr. Ballantine opened the meeting at 6:30 pm.

WEEKLY BRIEFING

A. Sewerage Work Improvement Phase 2 – Contract #1 – Construction Schedule – Weekly Update

Mr. Clark said that he had two things tonight on the sewer work, they did receive the three week look ahead and there will be one crew focused on Route 137. The pipe is 21 to 26 feet deep and that is going slow, though they are making progress. This is the area on Route 137, from Stop and Shop to Cemetery Road, and it is expected to take to the end of November. On Route 39 they have added a second crew and they are working from Spence's Trace to the 400 Plaza. They are trying to not to have both roadways closed, but the power people specifically asked to get into that area.

He is having a meeting at the end of the week with the Our Company. He has gone out to take a look, and Selectmen are welcome to going out as well. Hard hats and safety vests are required.

Mr. Clark also took a moment to explain to the Chairman that he understands he has missed some meetings and has had some family concerns that have taken him away a bit. He asks for their understanding as he works through that. He is available and will continue to serve the Town. Mr. Ballantine said, that as Chairman, he has told Mr. Clark to put his family first.

PUBLIC COMMENTS/ANNOUNCEMENTS

- A. Ms. Carolyn Carey, Director of the Community Center, just wanted to remind everyone that on Friday from 5:00 pm to 8:00 pm, at the Community Center, there will be the boutique to pick out a costume, they have fun games and all is free. They will also be having the Halloween party on October 31st and, she commented how thankful they are for the businesses in town.

Ms. Carey also made note that they have requested to be on the agenda for next week about the Seaside Marketplace. This is the right time to start looking at it, as people are looking at their schedules. They will have some recommendations for the Board.

- B. Ms. Erica Strzepek, Program Aide for the Cultural Center, wanted to announce that they are starting to plan for ArtWeek, which will be May 1st through the 10th. Harwich will be a featured case study on the ArtWeek website. She said that Ms. Sue Dahling Sullivan, the ArtWeek Lead Champion and Chief Strategic Officer of the Boch Center, and is the festival producer, will be doing a Sparks session on November 14th from 2:00 pm to 3:00 pm. This will be held in room four, at the Community Center. The Sparks session is a good time to ask questions and to get guidance. They open early online registration is in November.

Mr. Ballantine asked about the website, they will be featured in. Ms. Strzepek replied that it is www.ArtWeekMA.org. This will showcase how Harwich has really grown ArtWeek, and how it is becoming a bigger community event for the Town.

- C. Ms. Cyndi Williams, Executive Director, Harwich Chamber of Commerce, announced that this week is restaurant week for Harwich. They have 12 restaurants participating and information can be found on their website. Ms. Williams is also doing a daily video on Facebook.

- D. Ms. Cynthia Hartman, artist and resident of Harwich Port, said that she was here to discuss the Bottle Project. Her goal tonight is to explain the project, answer questions, and ask that they vote on the final installation place, at the next Town Meeting.

Mr. Ballantine agreed she could give them an explanation and it can go on the agenda next week, for a vote. Ms. Hartman then explained that the Bottle Project is supported by a grant from the Harwich Cultural Council, the Cultural Center and herself as the designer, and Baskin's Ace Hardware has donated all the paint and supplies. It is a project created by the community for the community; which involves cutting plastic water bottles, painting them and putting them into a canvas. It has received a lot of publicity and it shows the community that we care about our plastic disposal and there are other ways to use this kind of trash.

Ms. Hartman said that there are two places they are looking at putting the final project; the Cultural Center, or the new Harbor Master office. She would also be happy, if they have other ideas. She said that it has received interest from the Blue Institute International World Wide Ocean Conference. They have asked if they could speak about or present it at their conference. Also, a national organization called the Surfrider and Wellfleet SPAT have expressed interest. She said the final goal is to install it in time for the Christmas stroll.

Mr. Ballantine asked where she was getting the bottles. Ms. Hartman replied that the community has been bringing them to her, instead of the dump. Mr. Ballantine also asked what the size of the final product was going to be. She replied, that it the maximum that it will be is 4' x 8', she has looked at also as a chandelier. However, the final location will determine the size.

Mr. MacAskill commented if they are going to vote next week they should receive a memo from the considered locations showing approval. Mr. Ballantine agreed and asked Mr. Clark to review that, and also to find out if any permits would be needed. Ms. Hartman confirmed that it is currently at the Cultural Center and they are welcome to view it, but she will be adding her twist to it now so it will be changing. Mr. Ballantine ended with a thank you and they will follow through.

CONSENT AGENDA

- A. Vote to accept the resignation of Christopher Rockett, Community Preservation Committee effective 10.3.19
- B. Vote to affirm the re-appointment of Ralph Smith to the Community Center Facilities term to expire 6.30.22

- C. Vote to affirm the appointment of Matt Antoine to the Board of Health , full position, term to expire 6.30.20
- D. Vote to affirm the appointment of Arthur Rouse to the Planning Board, alternate position term to expire 6.30.20
- E. Vote to affirm the appointment of Heather Skowronek to the Noise Committee, full business position, term to expire 12.31.20
- F. Request to waive the room rental fee of \$100.00 for Monomoy High's National Art Honor Society. The event will be held on 10/23/19 at 6:30 PM at the Harwich Cultural Center

Mr. Ford moved to accept the Consent Agenda items A, B, C, D, E and F, listed above. Seconded by Mr. Howell.

Mr. Ford mentioned, that as they nominate names for each of these positions, it would be nice if the people on the nomination committees could just give a little background on the people and why they are appropriate. It may be helpful, and just a suggestion he is throwing out.

All in favor, motion carried by unanimous vote.

NEW BUSINESS

- A. 10.5.19 - Noise violation by Embers submitted by the Police Chief - schedule Public Hearing and designate the Town Administrator as Hearing Officer

Mr. Clark said that he had a conversation with the attorney and is waiting for a recommendation on the first three violations, which they already had a hearing on. Then subsequent to that, they had two additional violations that the Board voted on a week or so ago. Mr. Clark said that on October 5th they also had an additional violation. His goal would be to schedule the three violations, and to take all three at one hearing. He asked for the Board appoint him as the Hearing Officer again, and they will go through them.

Mr. MacAskill moved to send the noise violation by Embers submitted by the Police Chief to the Town Administrator as Hearing Officer. Seconded by Mr. Howell.

Mr. Ballantine asked if these are six different violations, by six different individuals that issued the complaint. Mr. Clark believes they are all different.

All in favor, motion carried by unanimous vote.

B. East Harwich Fire Station – Discussion & Possible Vote

Mr. Clark provided a quick overview of an image that he sent to the Board. He said that it makes sense at this point, to move forward with the demolition. He said that he had shared the letter from someone that had expressed an interest in the building, however, the recommendation from staff, is still to go ahead with the demolition.

Chief Norman Clarke, Harwich Fire Department, said that he had toured the site with staff and the Administrator last week, to get a flavor of what they are talking about. He added that he will take some responsibility for someone approaching about the building, which he thought was a great idea. However, that does not mean that it can be done. He said that when you drive around the building, you see just how close the new station is. He does believe that the land is worth more than the building. Chief Clarke said that he was thrilled to see there was interest to reuse the building, and he hopes the interest will continue to the property. After really taking a hard look and listening to the professionals, the prudent thing to do is to follow the original plan, and take the building down.

Mr. MacAskill moves to continue as originally planned and demolish the East Harwich Fire Department. Seconded by Mr. Howell. All in favor, motion carried by unanimous vote.

CONTRACTS

A. Change Order for Fire Station #2 in the amount of \$41,731.16 – Approve and authorize the Chair to sign

Mr. Powers explained that this is a very straightforward change order and this will be change order number seven for Fire Station #2. He said that Chief Clarke presented it, the procurement team went over it, and they recommend that the Board approve it and authorize the Chairman to sign.

Chief Clarke said that as he had mentioned before, he tries to group change orders together for a full vision of what they are doing. They have tried to minimize change orders, but they have to make changes and adjustments. He is happy to answer questions and ask for their support.

Mr. McManus asked about the completion of epoxy floors and lines, as originally proposed. He asked if that is the lines in the parking lot. Chief Clarke answered, that it was about the epoxy floors that had called for backup lines and squares for the trucks to park. Through the process to put specifications together, it was missed.

Mr. Howell moved to approve the change order for Fire Station #2 in the amount of \$41,731.16, upon the recommendation of the Assistant Town Administrator. Seconded by Mr. MacAskill with discussion.

Mr. MacAskill would like to know if there is a pending change order for the septic and waste water, as well. Chief Clarke confirmed that there is, and the amount is \$18,000, though it has not been processed yet.

All in favor, motion carried by unanimous vote.

B. Overview of Phase 2 Sewer Project

C. Discussion and possible vote to award the Phase 2 Contract 2 Sewer Project to RJV Construction Corp - \$6,621,306.25

MOTION:

Authorize the Town Administrator to execute the Phase 2 Contract 2 CWSRF4424/2 to RJV Construction Corp in the amount of \$6,621,306.25

Mr. Clark provided an overview as requested by Chairman Ballantine. He said that CDM made recommendations for Phase 2 of the project, and in 2017 had put together the numbers and projections. Then in April of 2018, they had a request to update the numbers for Town Meeting. As shown, the numbers went up for construction from \$17,680,000 to \$18,500,000, and also for policing which went from \$389,000 to \$725,000. They also added in easement and legal for \$310,000. Also, for the Chatham Pump Station and the agreement with Chatham that we share a proportional cost and that number was recalibrated and went from \$2,150,000 to \$2,950,000.

Mr. Clark said he does not have all the answers tonight, but the construction numbers were really in the wheelhouse of CDM, and he found out, after the fact, that they only did an internal estimate. They did the estimation and as you can see it went up from \$18.5 million to \$26.5 million. As shown on the cost summary variations, it is not shown on the slide, but he feels it is on CDM by using an in-house side of their company. They are an excellent design firm, but he has had real issue with the contractors' side and their estimates. The ones they had provided for what they saw for April 2018, the design plans were only at 50% complete. They had to increase to the distance of the pipe and that increased cost. There have been design changes and design of the pump station buildings. They were going to do similar to what Chatham did, but a decision was made to drop the costs of the easement. Mr. Clark said that more significantly has been the market conditions, they had anticipated getting eight to ten bidders, but only got three or four. He said the timing of the project and number of contractors interested had an impact. He said that also the paving costs increased by 50%. Mr. Clark thinks that they have realized now that the market conditions were an impact for contract 1, and they are on target for contract 2. The Our Company won the contract on contract 1, and RJV won the contract for contract 2, and it does show that market conditions do have a relevancy to the contracts.

Mr. Clark said in regards to the decrease in costs to the taxpayers on interest, he said that they will need to look at things over time, and the decisions that were made. The original estimate was for \$22.4 million, with \$17.7 million of construction costs. Also, to remind folks, SRF, the State Revolving Loan Fund, only funds the \$17.7 million, the construction piece. The town has to go out to the market place for all the design work and other peripherals. Projections were made to show what the impact would be, if not funded by SRF. Interest cost would be around \$15 million, for over 30 years at a 4% rate.

In April 2018, there was an update of \$24.8 million with \$18.5 million in construction costs. They started getting more information, once the agreement with Chatham was finalized. The projections made went down to 2%, assuming they would make it to the funded portion of the SRF list. The SRF is submitted throughout the state and they can only fund a certain amount, so the higher you are on the list, the better. The Town is very lucky to be first on the list. Now looking at 2019, they are number one on the priority list and the Town is now eligible for 0% interest, for contract 1 and \$11.3 million for 1/2 % of loan forgiveness that was about \$400,000 worth of savings. So, not

an insignificant amount of money. Mr. Clark said that if the Board approves contract 2, it would get us closer to spending the \$18.5 million, which was approved at the 2018 Town Meeting, and would be at the 0% interest. We did miss our window for the loan forgiveness, so it would not be included in this second round.

Mr. Clark said that one of the questions that came up recently at the three town meeting, with the three Boards of Selectmen, was what happened to the original \$240 million. Mr. Clark explained that the number was generated in 2014 and when you compound out a 3% construction inflation, it goes to \$313,145,564 in 2023. This does not include any pending revisions to the CWMP, with completed work and DHY assumptions. For example, the \$240 million includes in there the treatment plant located in Harwich, at the DPW facility, was in the ballpark of about \$60 million. So, to add in the revised CWMP that includes the DHY work, that number of \$60 million goes down plant only to about \$17-\$18 million. However, there would then be additional piping costs to get the piping to that area. So, the savings would not be the delta between the \$60 and the \$18, it would be a lesser number to get pipe to the other areas.

Mr. Clark next explained that Mr. Mike Guidice, CDM Smith, provided a breakdown of the costs for phase 2. This showed that from the 2018 Town Meeting the \$18.5 million and the Chatham Pumping Station at the \$2.95 million, with the total amount of appropriation being \$21,450,000. The contract price for bid 1, the Our Company work, which is being done now is \$11,368,663, and requirement by SRF to have a 5% contingency, which has been built in.

Mr. Clark said that what is being asked in front of the Board tonight is for contract 2, which was priced in such a way to maximize the available amount of money, to do as much as they could of phase 2. That came in at \$6,621,306 again with a 5% contingency built of \$331,065. The Chatham Pump Station came in less under contract 2, and the remaining construction funds will be \$150,533. Then you can see the additional phase 2 appropriation of \$610,000 for general services and the other town costs.

He said he has had a lot of opportunity to think about this, and how he felt that they did not need to go out to bid to select a designer, that CDM deserved the opportunity. He does feel that they have had misses. He does feel that they need to finish with them, but it will need to go out to a third contract and that

should go out to bid. They should see if they can find a firm with more reliable numbers to move forward with.

Mr. Howell read from an email string from June 17th, which was the night they were told they needed to act now or lose \$15 million and there wouldn't be any zero percent financing. The email was from Nate Keenan, Deputy Director of Massachusetts Clean Water Trust, to the MassDEP asking about a waiver for the Town of Harwich, for missing the deadline. The response said that they don't provide waivers for that, and the town would lose the principle forgiveness for missing the June 30th deadline. The town does need to provide a revised project schedule and ask for an extension for awarding of the contract. If it is accepted, they will grant a waiver for awarding the contract, but not for principle forgiveness at zero percent. There was also an email from the town's Financial Advisor to the Finance Director over-viewing the loan options; which did not provide principle forgiveness and the charges that would incur. Mr. Howell's second thought was that he agrees with the Administrator about CDM Smith, and he had fought to make it a competitive bid. The actual bid specs the day they issued it, was even more off. In comparison, Chatham's estimate, using Weston & Sampson, was spot on. The prices were higher, but the estimates were consistent with the bids received. This was the same for Barnstable. The final thing is why this got broken out into three projects, instead of one and lost the opportunity to get larger companies to bid on it, with a larger project. They are in a bad position, and if they award this contract they will have no control. He will not vote for a contract 2 to only get 2/3rds of the project done.

Mr. MacAskill thanked the Town Administrator for admitting the need to look at another engineering firm for the next projects. He is also concerned with spending this money and awarding this contract. They have done nothing but rush from the beginning of this. They said at the Town Meeting they had solid estimates, because that is what they were told. Mr. MacAskill said that he voted for the last contract because he didn't want to cost the tax payer's \$15 million. He was disheartened to find out the savings were not that. Why were they told \$15 million, and he had done the math, it did not come up with that as a savings. The bids that came in, were all very close, which means that they were correct, and the engineer just plain screwed up. They rushed from the beginning and now is an opportunity, not to rush. They are dropping 1/3 of the homes and to go back to Town Meeting, apologize after the fact and say to get to where they are supposed to get to, will cost \$8 million more. They don't have any exact costs and could not answer most of the questions

that were asked of them at the three town meeting. Mr. MacAskill said that Mr. David Young, CDM Smith, said that he had answered those questions, but he has not. There has been frustration from the Wastewater support committee from the beginning and they have all resigned, so they have no representation there. He also pointed out that the person they hired for a Wastewater Superintendent has been involved in very little and was not included by the engineer or the Town Administrator. The three town meeting, every other town brought their professionals, Harwich did not, and the questions that came up to Harwich, they could not answer. Are they really going to go to town meeting spend the rest of this contract money, without an apology, or take the time to demand answers. They are doing a terrible disservice to this Town. They are not prepared and they need to go back and look at what they are doing and what else may have been forgotten.

Mr. Howell asked if the total amount of the \$24 million dollars, was a proportional short fall. If it was partly design, engineering and construction or was the design and engineering paid and the shortfall falls to construction.

Mr. Clark said that was a great question, he has been advised that they will probably expend their original appropriation to finish contract 2 and probably will be coming to the town and asking for additional for contract 3.

Mr. Ford then asked to Mr. Clark, if it would be wiser to take a look at what they have to do going forward to rebid that, or potentially paying more money. Would it be more fiscally responsible to rebid, even with contract 2, or will that hurt tax payers more? He said that they are trying to protect the tax payers.

Mr. Clark has relied on CDM for a lot of the information that he has made decisions on, because he is not an engineer. What he is recommending is that they have a known commodity and a known bid, so they should move forward. If they wait, they would have the increase with the 3% construction inflation, plus they are number 1 on the list, with 0% interest. It makes sense to go forward and finish with this phase. Mr. Clark had asked CDM to put together Phase 3. However, to make the case for the \$8.4 million, they do know the bid environment and anything they do for the town perspective, would have to go out to the bid on contract 3, to present before Town Meeting. This is not a good position to be in, having to rely on CDM, but knowing that they have a 0 % and that they are number one on the list, it makes sense to go forward and then create a bid environment.

Mr. Ford said that his great concern is putting them in a position where they will pay more. He said that he agrees, it has been a huge disappointment by how they have been guided by CDM, and it is clear the Board has some real reservation with the relationship. He doesn't want to jump in with a reaction and end up costing the tax payers more money.

Mr. MacAskill asked, so it is clear to the public, is if the Town is in jeopardy of losing the 0% financing for phase 2. Mr. Clark said that the town is on the list, but if there is a delay, they would need to apply to get an extension.

Mr. MacAskill also commented on the 3% inflation and that it is standard practice for contractors to hold price, while getting through political actions like Town Meeting. They should go back to the contractor and ask them to hold the price without the inflation, which has not been done. So that is an answer to a question that they have not asked yet, and also a larger contract would likely have less cost. He asked if Mr. Clark is saying with certainty that this is going to go up, more than 3%, and our savings is going to be less than 3%, without doing any homework, and they are being asked to vote on this tonight?

Mr. Clark said that he is not saying that and he could not speculate. In the past it has been 3% and to his point the economy of scales, the bigger the project, potentially the better off you can be with price. In this circumstance though, you are talking about going out in different areas, that would not be contiguous. He is not necessarily sure that the economy of scales and having construction done in one area would yield as much benefit. There are a few operational concerns.

Mr. MacAskill said that they had told Town Meeting, very clearly, what they were going to do in Phase 2. He said that in all of their conversations and everything they had done was for sewerage 600 homes. There was an \$8 million mistake made, which they do owe the public an apology for, and an explanation for. He does not have a lot of confidence in the engineering plans and they should have a review to see if they are going down 28', where perhaps they shouldn't be. He would also like to know what the Town of Chatham thinks of only sewerage 400 homes. They needed the flow, and now is the Town paying for the 600 homes regardless? Mr. MacAskill repeated that there is a lot that that they do not know tonight, and they are being asked to vote on a contract.

Mr. Clark said that he had advocated not to pay until they have the flow going, but it was decided to just pay on a schedule. So, over seven years, they pay the full amount. He said that it is to their advantage to do the construction sooner than later.

Mr. MacAskill replied that they voted and the deal is what it is. He said that without knowing those numbers it is going to add to everything else that they are doing. As far as DHY goes, they are not even close, and he hopes the board will take the time to have long conversations and to get confidence back in the voters.

Mr. Ford asked if they actually need to vote on this tonight and Mr. Ballantine confirmed that they do not, because they need to have some questions answered first.

Mr. Ballantine said that they are all disturbed by how poorly the estimates were made. He doesn't understand how CDM Smith broke their own protocol and only used in-house. However, where he does disagree somewhat with Mr. Howell and Mr. MacAskill, not with their concerns, but about the estimates. He said that they have good bids and even though they missed the estimate by large numbers, he is comfortable with contract one. He said that they had five bids, and four of them came in very close. The bids for contract two have also come in very close, so he is confident the cost is the cost. They do have some serious trust to build up in the town from missing the bid by so much. He would propose to bring it back.

Mr. MacAskill said that he agrees and this is not about the contractor. They have a great estimate. However, it is more that we told the voters and going back and apologizing to them and they should vote, not necessarily us.

Mr. Ballantine further explained that although they messed up, the cost of doing this work, he is comfortable with. There is a lot of debate on the estimates, but the cost of doing work is what it is at this time.

Mr. Howell said that he is hoping they can talk about this with the knowledge of if they can keep their bid price. However, again quoting from the warrant article, *this will fully implement phase 2 of a regulatory required plan*. He said that they promised them up front that they were going to finish up with that amount of money. They shouldn't have gone forward, if they knew they

were going to run out of money. Mr. Howell said that they were essentially railroaded, they had thirteen days left until June 30th, and they were told they were going to save \$15 million, that was not true. They were told they were going to lose the 0% interest, that was not true. Mr. Howell said that all it took him was about a half hour with the Director of Finance and making some phone calls to find out it wasn't true. It is not speculative, it is the DEP and the Clean Water Trust, they are in writing. He said that they need to be able to reestablish some trust with the public that they are partners with them.

Mr. Ballantine said that they should get answers to their questions and bring it back.

Mr. Clark said to clarify, on the IMA, the \$7 million gets paid over seven years period. The amount of flow is on us. He is not sure what the question is. Mr. Ballantine asked if he could recheck on the IMA what the start date was supposed to be and what the obligation was to start delivering flow to them.

Mr. Clark said number one the amount of flow does not matter to Chatham, they get paid no matter what, on a timeline. It accelerates the timeline if they send them flow early. He said that the big think they were successful in doing is on the coordination. It did not make any sense to do contract one or two, if Chatham did not have the pipe to accept it. He also said to Mr. MacAskill's point, he thinks Chatham would like to have the 300,000 gallons so that they could assess the plant. He will put the IMA in the packet for them to go through it. He said the follow up question is how long will RJV be willing to hold their price.

Mr. MacAskill said, just as a follow-up, the tax payers need to know that they will maximize the \$7 million investment, first and foremost. If they are going to recommend spending the \$8 million to finish phase 3, it is important for tax payers to know that they are paying the \$7 million no matter what. As far as O&M costs and flow costs, in those negotiations, in good faith they had told Chatham that they were going to deliver from 600 homes, they did not say night. They got approved at Town Meeting for \$21.5 million to sewer 600 homes, and they negotiated in good faith and now they are taking a third out.

He thinks their projections for O&M costs and everything else was under the assumption that they were going to do what they said they would do. He would like a meeting to happen between Chatham and the Town Administrator and

to hear them say that they are ok with the change. He does not think that they should assume anything.

Mr. Stan Pastuzak of Nor'east Drive approached the Board to share three points. He agrees Mr. Ballantine that the biggest problem is the estimate not the costs. They have good bids right now. He is not sure why they would not go with those bids, because that is not going to change. Mr. Pastuzak said as for what Mr. MacAskill had said, he wanted to know if there was an economy of scale, of combining 400 homes, or continuing with the 200 and then going to the town with the other 200. If there is not an economy of scale, he is not sure why they wouldn't go with the bid right now. Also, he wanted to know if there was a problem, why didn't they stop with approving contract one, if they thought they would not be able to finish the project with the money they had? They knew that when contract 1 was bid out.

Mr. MacAskill said they were told that the Town of Harwich taxpayers were going to lose \$15 to \$21 million, if the contract was not voted, on that night. He said that he had made his vote that night and the statement, that the savings to the tax payers were going to be \$15 million. He said that the reason why they are not bidding out and approving contract 2, because they have to go back for the \$8 million. He said that it is about the taxpayers in East Harwich, they want a shot at this and want to understand these mistakes. They want a shot at this, and they need answers to the questions. If they are going to approve the contract they would have spent everything Town Meeting said they weren't and he is not comfortable doing that, until they have answers to the questions. They are basically forcing an extra \$8 million on the taxpayers.

Mr. Pastuzak agreed that there should be more people there at the meeting to ask some of these questions.

Mr. Ballantine said to remind everyone this is not an issue they are just doing, this is an issue for them because they are trying to clean their abatements, they are under regulatory requirements for that. They still have a lawsuit that is not settled. There was an article in the Cape Cod times arguing that they are not moving fast enough. He said that he takes the point that they were misled and moving too fast for the dollar value, but they felt they were under some pressure. They will bring this back and just wanted to make statement that they are not doing this, just to dig holes.

Mr. McManus added that they all have questions about how they have been served by CDM. He thinks the general conclusion is they could have been served much better. He wants to make it clear that he is not saying this in any way to offer an excuse, but he thinks as they move forward, it would be good to hire a Project Manager. As plans are brought forward, to make sure that schedules are followed, and all the things a project manager does in construction. For the design, the costs are what they are. They should look at the mobilization costs.

Mr. Ballantine asked Mr. Clark to find out how much it would cost to have an independent review of the design? To see if we want to move forward. Mr. Clark said that he could check with Weston & Sampson.

Mr. Ballantine thanked Mr. Clark and the Selectmen for the conversation.

TOWN ADMINISTRATOR'S REPORTS

A. Preliminary Discussion - Potential Easement/License Agreement (between Zylpha Road & Ocean Avenue)

Mr. Clark said that it came to his attention that the property owner with property between Ocean Avenue and Zylpha Road that has a seawall. The seawall part is on Town property. He explained that what they have done in the past is to put together a license agreement to allow the homeowners to reconstruct the wall and make improvements. They will do an easement at Town Meeting at a subsequent date. Mr. Clark said that they are represented by Attorney Crowell, and he had told him that he would bring this in front of the Board and bring the form of a license agreement. He said that if they were to do a license agreement for the value of the land, or the value of the easement, they would need to get an appraisal and then go to Town Meeting. Then the homeowners to pay for the town property that their structure is on. He said that the attorney did confirm that this is a course that they would like to pursue.

Mr. Clark said this is informational and once the license agreement is done, they will put it on the agenda.

B. Castle in the Cloud Discussion

Mr. Clark said that he does not want to be in the middle of this. He said that the School Department is on one page about what they would like with plans to the CPC to change out the playground and the renovations. Mr. Clark said that he was asked to attend a meeting on the 24th, to go and look at the site with Mr. Scott Carpenter, Superintendent and some people from the school. He said that he would like to know if the Board is in favor of replacing it or not. He will work with the insurance company, to limit liability for the Town, and again, he is looking for direction from the Board.

Mr. MacAskill said that they put it on the agenda for next week. He said that based on the safety audit, the school should shut the playground down and stop letting kids use it. He said that is not their decision, they are a tenant and if they deem it unsafe, they should shut it down. When are they going to make that decision? Also, he looked at the plan they submitted to CPC. He asked if there are any thoughts of them coming in front of the Board of Selectmen, since they are the ones that actually control the land behind the middle school, and asking to use that land, before they submit an application. He said that he is not against it, but they should ask them.

Mr. Ballantine, agrees about the safety issue being a liability, and it is hurting kids. He said the second part he is concerned about, is the grand plan which is very expensive. If they are going to go to CPC for this, they should at least look at fixing the playground problem. He said that the dollar amount they were looking at would take all the CPC funding they had, and they have other issues too.

Mr. Howell said he was the president of the organization that built the playground. He said that there was not a single penny that came from state federal or local funds, it was all a volunteer organization. He listed names of those that were the primary fundraisers. He said that he was on the technical side. He said that he had started out in the Federal Government and was the person that issued the schedule contract for playgrounds. He said that he was involved in all the spec'd out stuff, and he ordered all of it. Mr. Howell said that he is really appalled they never did any maintenance on it. There was no proposal to refurbish the playground, they just planned to tear down, and that was before the safety audit and all of the assessments. He is not surprised it is splintering because they had done nothing to sand it or seal it. He agrees with Mr. MacAskill, they need to close this down. They have never

replenished the fibar and it now just wood chips, and it is not good. He would have started with letters to find out what the costs would be in sections. He knows how the whole thing is constructed, but they have not talked to him.

Mr. Ballantine said we should bring this back and we need a clear understanding of where the boundaries are, and where the responsibilities are.

Mr. Ford said that the CPC was surprised too and there is a limit the amount of money they have available. There were a lot of assumptions made.

Mr. McManus said he has two questions, one about the playground, and the second about the grant. He doesn't see how they can present a project on property, they don't have control over. He also said that the playground facility keeps being said it is about Monomoy, however, up until six or seven years ago, it was the Town and they approved the maintenance.

Mr. Ballantine said the past is the past, and their concern should be going forward. Mr. MacAskill said the number one concern is safety and it is still on Harwich, they are our kids, it is still us.

Mr. Clark said that the meeting for the playground is on the 24th at 10:00 am. If anyone would like to join in. Mr. Ballantine asked Mr. Clark to post the meeting, so it is considered a public meeting.

C. Preliminary Capital Budget Plan

Mr. Clark said he put the material in the budget, so they could take a look at it. They just had the Capital Outlay Committee meeting that afternoon, so he will update the information. He will have an updated version and look at the budget calendar, if they want to have a preliminary look. He said that the Capital Outlay did vote on some items already and he will work to have it for next meeting. Mr. Clark said that Capital Outlay are meeting again on the 24th at 4:00 pm. They do want to make some adjustments and Mr. Clark will be sure to identify the changes for the Board.

D. Assumption on Budget Discussion

Mr. Clark that that he had heard some of the conversations, with Ms. Carol Coppola, Finance Director, about the short term rental money. He said that money is coming in now, and that money comes in as a local receipt. He said

that it is interesting that the town of Dennis has made a decision of putting 25% of this toward their sewer program. Really, right now it is a point of assumption to try and get a sense of the money that is coming in as a resource.

Mr. Ballantine said his question was, that as far as he knew, they hadn't gotten a report from the State yet. Do they know the amount of money coming in?

Mr. Clark said they took the hotel/motel statute and they amended it, so they get an amount of money that comes in from hotel/motel and they have not segmented off yet what is hotel/motel and what is short term rental. That is something that is having an effect of bringing in more money of local receipts.

Mr. MacAskill asked if this is assuming the 4% to 6%? Mr. Clark responded that he knows the Town of Dennis is looking to do the 4% to 6% change there too. He said that is something they could put into their assumptions, and to see early on if that is something they would want to consider. There are several towns on the Cape considering this.

Mr. Clark made the Board aware that the CVAC contracts were downstairs. He said that Ms. Argo brought them by, and he would plea with them to get their signatures.

SELECTMEN'S REPORT

Mr. MacAskill asked for a status update for the Firehouse on Bank Street. If they can get an update on when it will be torn down. Some interested neighbors said that there are animals living in there and they would like to know if the animals will be relocated or terminated prior to the tear down. Mr. Clark responded that they did do a 500 page report on the environmental concerns, and he did ask Mr. Sean Libby, Facilities Manager, to help do a spec to mediate that before being demolished.

Mr. McManus mentioned that another property in Town that neighbors have been wanting to see demolished, which is the one on Doane Rd. Mr. Clark said that he will get an update on the status.

ADJOURNMENT

Mr. MacAskill moved to adjourn at 8:13 pm. Seconded by Mr. Howell. All in favor, motion carried by unanimous vote.

Respectfully submitted,

Lisa Schwab
Board Secretary



Jean M. Lorizio, Esq.
Commission Chairman

**Commonwealth Of Massachusetts
Alcoholic Beverages Control Commission
95 Fourth Street, Suite 3
Chelsea, MA 02150-2358**

**2021
Retail License Renewal**

License Number: 03657-RS-0506	Municipality: HARWICH
License Name : 30 Earle Road LLC	License Class: Seasonal
DBA : The Commodore Inn	License Type: Restaurant
Premise Address: 30 Earle Road Harwich, MA 02671	License Category: All Alcoholic Beverages
Manager: John William Foley	

I hereby certify and swear under penalties of perjury that:

1. I am authorized to sign this renewal pursuant to M.G.L. Chapter 138;
2. The renewed license is of the same class, type, category as listed above;
3. The licensee has complied with all laws of the Commonwealth relating to taxes; and
4. The premises are now open for business (if not, explain below).

John W. Foley Jr.
Signature

John w foley jr.
Printed Name

3/10/21
Date

Manager
Title

Please sign this form only in the month of March and return to your Local Licensing Authority.

Additional Information:



Jean M. Lorizio, Esq.
Commission Chairman

Commonwealth Of Massachusetts
Alcoholic Beverages Control Commission
95 Fourth Street, Suite 3
Chelsea, MA 02150-2358

2021
Retail License Renewal

License Number: 00021-RS-0506

Municipality: HARWICH

License Name : Wychmere Harbor Functions Lp

License Class: Seasonal

DBA : Wychmere Harbor Beach And Tennis Club

License Type: Restaurant

Premise Address: 23 Snow Inn Road Harwich, MA 02646

License Category: All Alcoholic Beverages

Manager: Christopher Clifton Kolwicz

I hereby certify and swear under penalties of perjury that:

1. I am authorized to sign this renewal pursuant to M.G.L. Chapter 138;
2. The renewed license is of the same class, type, category as listed above;
3. The licensee has complied with all laws of the Commonwealth relating to taxes; and
4. The premises are now open for business (if not, explain below).



Signature



Date



Printed Name



Title

Please sign this form only in the month of March and return to your Local Licensing Authority.

Additional Information:





Jean M. Lorizio, Esq.
Commission Chairman

**Commonwealth Of Massachusetts
Alcoholic Beverages Control Commission
95 Fourth Street, Suite 3
Chelsea, MA 02150-2358**

**2021
Retail License Renewal**

License Number: 00012-HT-0506	Municipality: HARWICH
License Name : Pleasant Bay Group Inc	License Class: Seasonal
DBA : Wequassett Inn	License Type: Hotel/Innkeeper
Premise Address: 173 Route 28 Harwich, MA 02109	License Category: All Alcoholic Beverages
Manager: Mark J Novota	

I hereby certify and swear under penalties of perjury that:

1. I am authorized to sign this renewal pursuant to M.G.L. Chapter 138;
2. The renewed license is of the same class, type, category as listed above;
3. The licensee has complied with all laws of the Commonwealth relating to taxes; and
4. The premises are now open for business (if not, explain below).



Signature

3-4-21

Date

MARK NOVOTA

Printed Name

Managing Partner

Title

Please sign this form only in the month of March and return to your Local Licensing Authority.

Additional Information:



Jean M. Lorizio, Esq.
Commission Chairman

Commonwealth Of Massachusetts
Alcoholic Beverages Control Commission
95 Fourth Street, Suite 3
Chelsea, MA 02150-2358

2021
Retail License Renewal

License Number: 00088-GP-0506

Municipality: HARWICH

T.P.
License Name: LUCKY LABRADOR INC.
3/12/21
Go Industries Inc

License Class: Seasonal

DBA : Perks

License Type: General On-Premises

Premise Address: 545 Route 28 Harwich, MA 02645

License Category: All Alcoholic Beverages

Manager: Taylor Powell

I hereby certify and swear under penalties of perjury that:

1. I am authorized to sign this renewal pursuant to M.G.L. Chapter 138;
2. The renewed license is of the same class, type, category as listed above;
3. The licensee has complied with all laws of the Commonwealth relating to taxes; and
4. The premises are now open for business (if not, explain below).

Taylor Powell
Signature
TAYLOR POWELL
Printed Name

MARCH 12, 2021
Date
OWNER
Title

Please sign this form only in the month of March and return to your Local Licensing Authority.

Additional Information: Go industries inc. recently transferred this license for "PERKS" to LUCKY LABRADOR INC. TRANSFER WAS APPROVED BY THE ABCC AND THE TOWN OF HARWICH.



Jean M. Lorizio, Esq.
Commission Chairman

Commonwealth Of Massachusetts
Alcoholic Beverages Control Commission
95 Fourth Street, Suite 3
Chelsea, MA 02150-2358

2021
Retail License Renewal

License Number: 00055-RS-0506

Municipality: HARWICH

License Name : Ajj Corp

License Class: Seasonal

DBA : The Weatherdeck Restaurant

License Type: Restaurant

Premise Address: 168 Route 28 Harwich, MA 02110

License Category: Wines and Malt

Manager: George Argyriadis

I hereby certify and swear under penalties of perjury that:

1. I am authorized to sign this renewal pursuant to M.G.L. Chapter 138;
2. The renewed license is of the same class, type, category as listed above;
3. The licensee has complied with all laws of the Commonwealth relating to taxes; and
4. The premises are now open for business (if not, explain below).

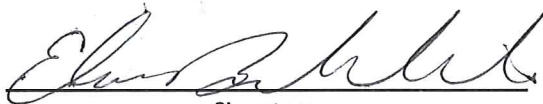

Signature

3/6/21
Date

Elaine Baraklilis

Printed Name

President
Title

Please sign this form only in the month of March and return to your Local Licensing Authority.

Additional Information:

seasonal, will open in April



OLD BUSINESS

Monomoy Regional School District FY22 Budget

TOWN OF HARWICH PRESENTATION

March 24, 2021

The 30,000 foot view

- The long term effects of the COVID pandemic are, as yet, unclear but they are likely to impact on our organization and finances.
- The declining number of children in Chatham, relative to Harwich, continues to shift the minimum required contribution (as calculated by the state) towards Harwich. Both Towns and MRSD have been working to find a fiscal solution in the short term.
- Overall there is a reduction in staffing that reflects the changing enrollment.
- This budget maintains all existing services and programs.

Budget Development Guidelines

- Support the district's Mission Statement
 - *Monomoy Regional School District is a community of learners of all ages focused on building knowledge, positive character, and resiliency in a safe, supportive, creative, and challenging environment*
- Support advancement of the district's new 2018-2022 Strategic Plan Objectives
 - Expand Community Engagement and Partnerships
 - Strengthen Social and Emotional Well-Being
 - Close the Achievement Gap
 - Improve Curriculum, Instruction and Assessment for All Learners
- Class sizes average 18±1 and middle/high school 19±2
- Data driven
- Transparent
- Collaborative - with staff, families and community
- Recognizes the financial environment of both towns

FY22 Budget Assumptions

- Anticipates level enrollment in our schools, with the high school continuing to grow in population, while the lower grades contract.
- No changes to services at the lower grades but reduction in staffing to reflect changing enrollment.
- Preliminary FY22 Ch70 and Minimum required contributions now available, and included in assessment.
- Health insurance rates now set and reflected in the budget.

Student trends

All Students Enrollment

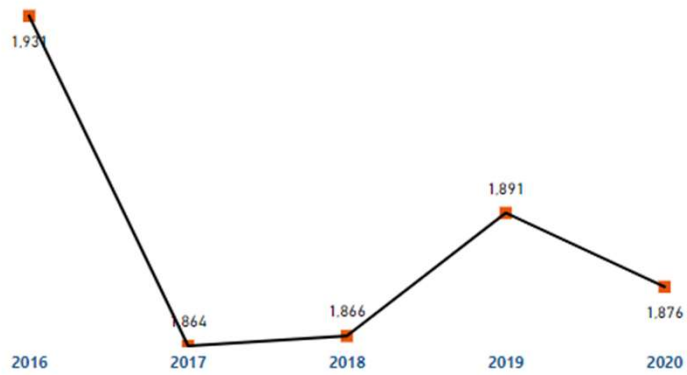

-3% -0.5%

District Change Over 5 Years

% Students with disabilities



-1%

7%

% English Learners

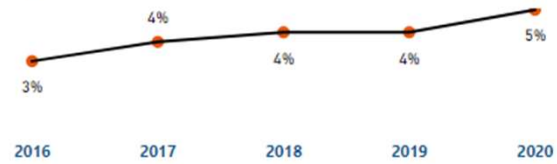

42%

20%

% Economically Disadvantaged

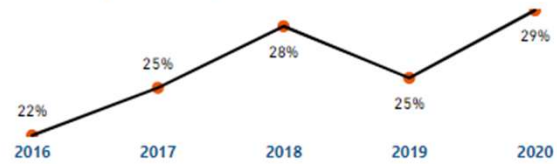

25%

19%

State Change Over 5 Years

Enrollment Trends By School

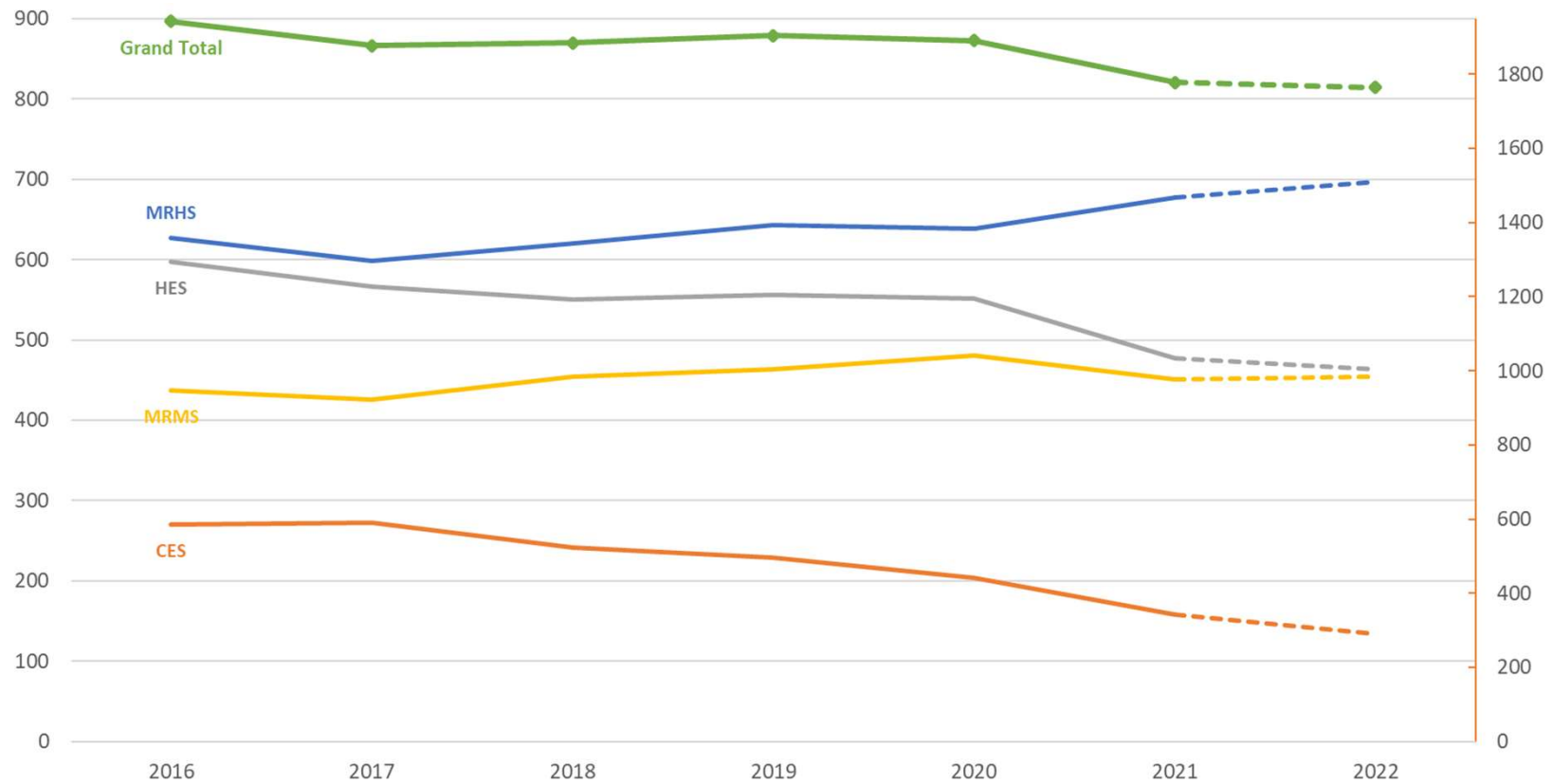

The District is maintaining class sizes with the projected enrollment for FY22

District Goal: Maintain programs across grade levels and educationally supportive class size guidelines of 19+/-2 students per class at the middle and high school and 18 +/-1 at the elementary level.



FY22 Budget By Category

Name	FY22 Budget - SC Approved 3/12/21	
District Leadership & Administration	\$	1,190,874
Instruction	\$	20,666,079
Operations & Maintenance	\$	3,314,529
Other School Services	\$	2,964,292
Programs With Other School Districts and Transfers Out	\$	3,480,128
Fixed Charges	\$	7,646,794
Capital	\$	363,813
Debt Retirement & Service	\$	1,934,625
Grand Total	\$	41,561,134

Budget Trend

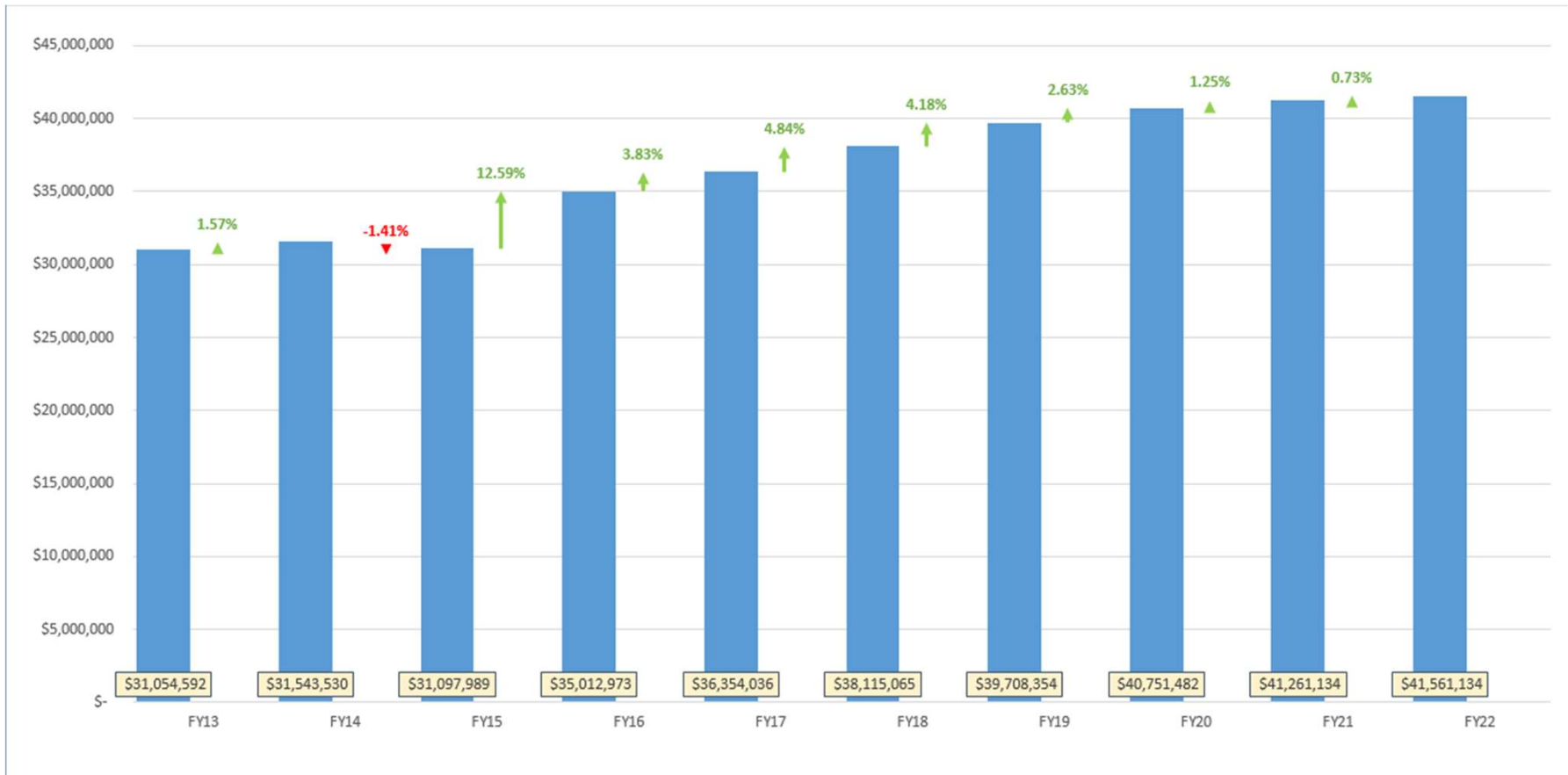

New needs have been identified by the Principals and Directors – those listed below are funded in the current budget.

School	Description	Amount
District	Retain one additional full time nurse	\$81,229
Technology	Increase Bandwidth to 2GB	\$8,400
Athletics	Unified Sports Coach	\$4,761
Athletics	Increase Athletic Trainer to full time position	\$25,000
District	Budget Sense conversion	\$13,383
District	ELL pre-screening/testing for summer (hours)	\$3,784
District	10 additional days for Team Chairs	\$13,364
MRHS	Math Interventionist	\$83,246
District	Replacement computers for Admin Assistants	\$15,000
MRMS	1FTE Reading Specialist	\$81,229
MRMS	Social Studies Textbooks (G6 & 7)	\$24,000
Technology	Additional 0.5FTE for Technology	\$25,844
MRHS	Chemistry Textbooks	\$12,000
CES	Increase Math Assistant Position to Full Time	\$20,400

Unfortunately not all requests from Principals and Directors could be funded in this budget. The following items are not budgeted.

School	Description	Amount
MRHS	US1 / US 2 textbooks	\$24,000
CES	Team Chair (OoD/CES/EC)	\$83,246
MRHS	0.5 Wellness Teacher	\$34,626
MRHS	Increase School year secretary to full year	\$10,680
MRMS	New Van MS Shells program	\$40,000
MRMS	Security Cameras (CES/HES/MRMS)	\$12,000
CES	Math Interventionist	\$83,246
District	0.5FTE Speech and Language	\$48,620
District	Curriculum Specialist	\$97,731
MRHS	Special Education teacher	\$83,246
MRMS	Math Interventionist	\$83,246
MRMS	0.5 FTE Custodian	\$19,370

Out of District Expenditure / Budget

- The chart below shows the out of district expenditure until 2020, the budget for 2021 and the draft budget for 2022. Our expenditure is offset by 'Circuit Breaker' reimbursement from the state.
- The circuit breaker revenue available to offset the budget increased for 2022.

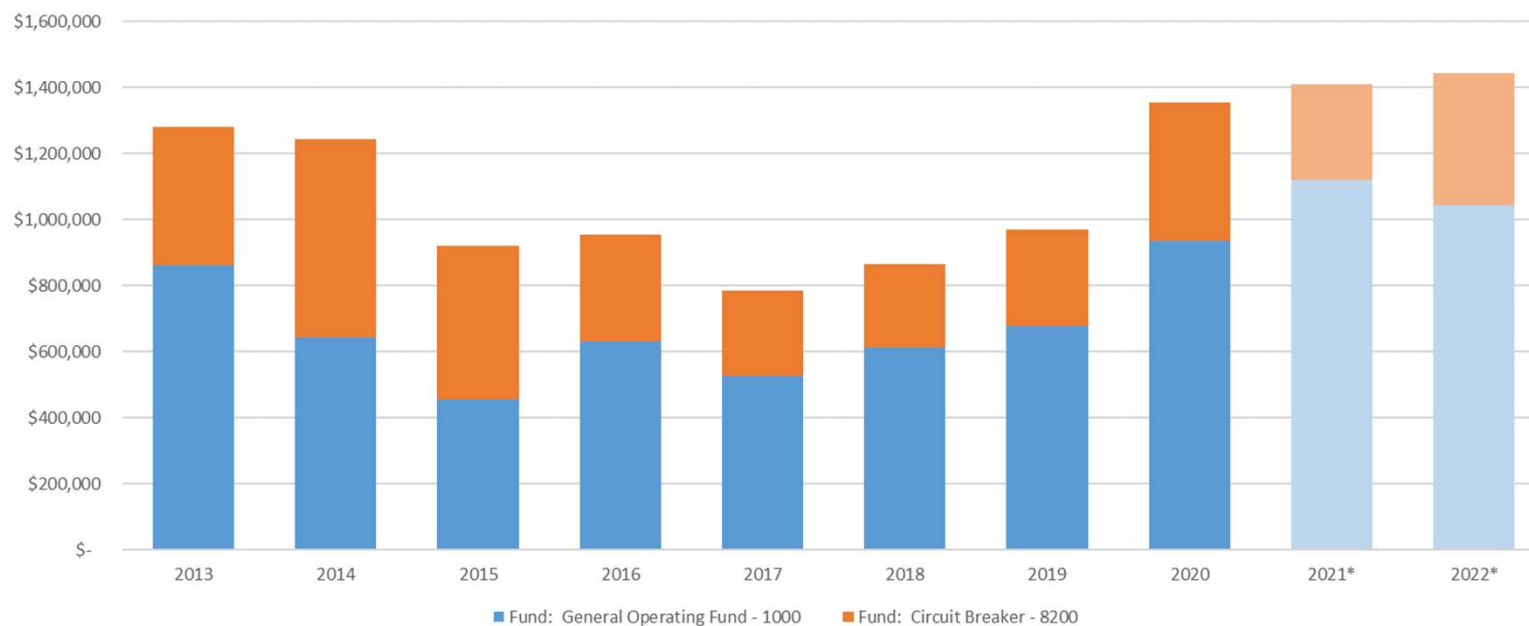

Tuition for School Choice and Charters

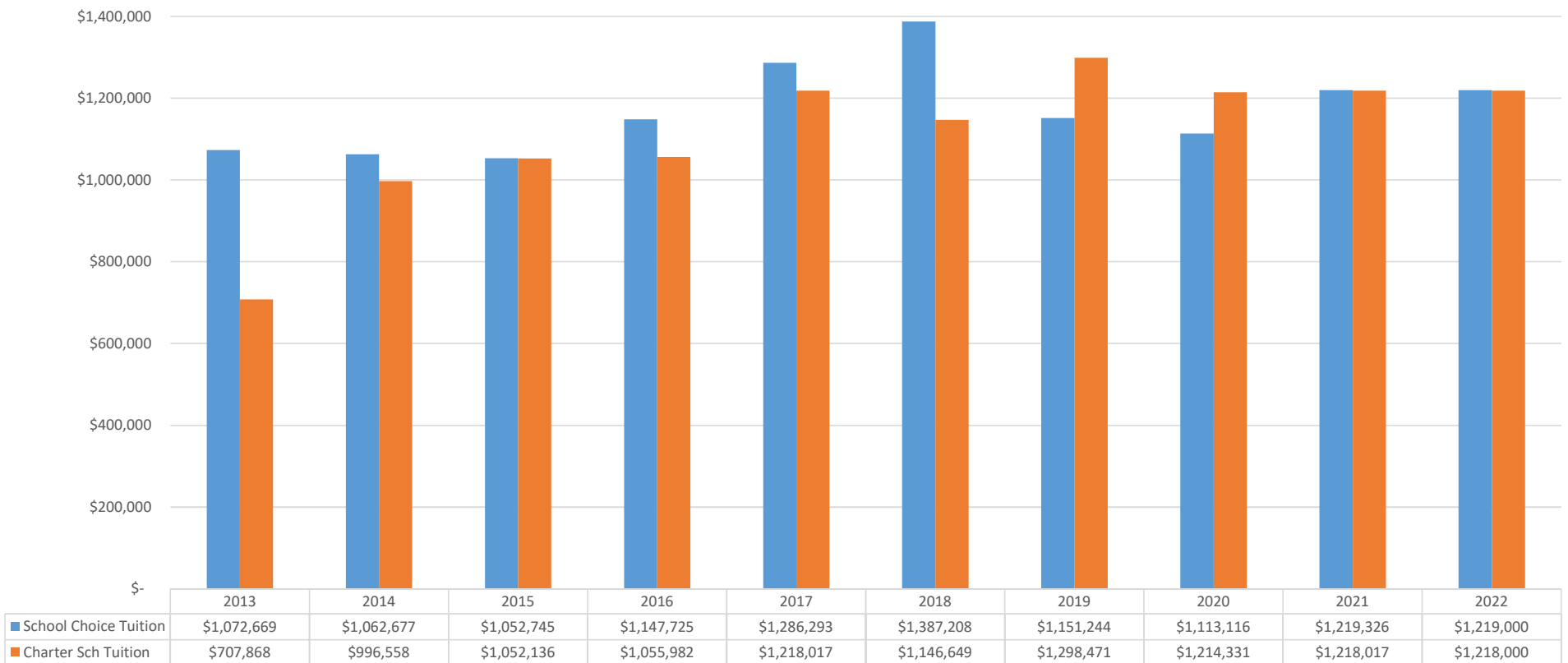

Employee Health Insurance

- The average increase in health insurance rates since FY13 has been around 7% however, there has not been an increase since FY19
- Rates to increase between 2% and 3% for FY22, and there will be a 'premium holiday' in the fall of this year. Overall, these changes reduce the health insurance budget for FY22.

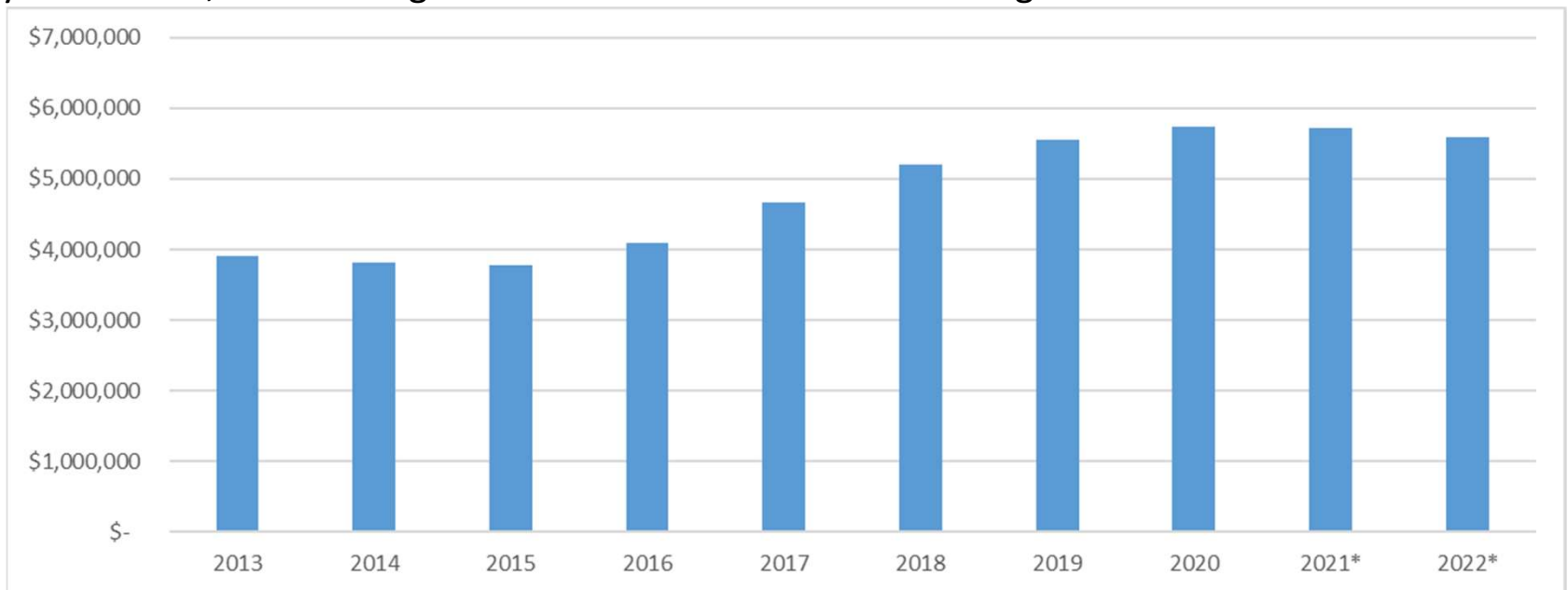

Other Drivers

- **Custodial Supplies & Services:** Level funded to reflect historic expenditure. However, \$33,000 in additional funding provided as contingency for COVID related expenditure.
- **Substitutes:** \$89,000 increase to bring in line with historic trend. New accounts added for special education substitutes.
- **Heating:** 0% increase on 2021 Budget – equates to approximately 15% increase on the 2018-2020 three year average expenditure as the contract for gas expires in April 2021, expect increased rate in new contract.
- **Utilities:** Level budgeted (0%). Although there has been an increase in expenditure this is still trending below budget. Savings are expected from the High School Solar Project and a new electricity supply contract. This category also includes water, phones and trash.
- **COVID:** There have been increased demands on staffing, technology and facilities. There is uncertainty over the impact on the FY22 school year, including on possible unemployment and other employee costs.

There is a small increase in capital expenditure this year. The district will need more significant investment in coming years.

Facilities

Chatham ES / Harwich ES / Middle School

- Replace Phones/PA System – Phase 1 - \$95,000

Harwich Elementary School

- Repair window seals - \$7,000
- Water bubbler for cafeteria - \$8,000

Monomoy Regional Middle School

- Auditorium Lighting - \$10,000

Monomoy Regional High School

- Replace vehicle for student community programs (3 year lease payment) - \$10,000

District

- Stabilization payment - \$50,000

Technology

Chatham Elementary School

- Promethean Boards - \$16,864

Harwich Elementary School

- Promethean Boards - \$16,865

Monomoy Regional Middle School

- Teacher Laptops - \$10,378
- Chromebooks - \$51,225

Monomoy Regional High School

- MAC Lab, Graphics Lab and Robotics Lab - \$35,853
- Chromebooks - \$52,628

District expenditure is offset by revenue from a number of major sources.

- Historically, the offset has been relatively stable. The dip from 2020 actual to 2021 budget is driven by circuit breaker revenue.

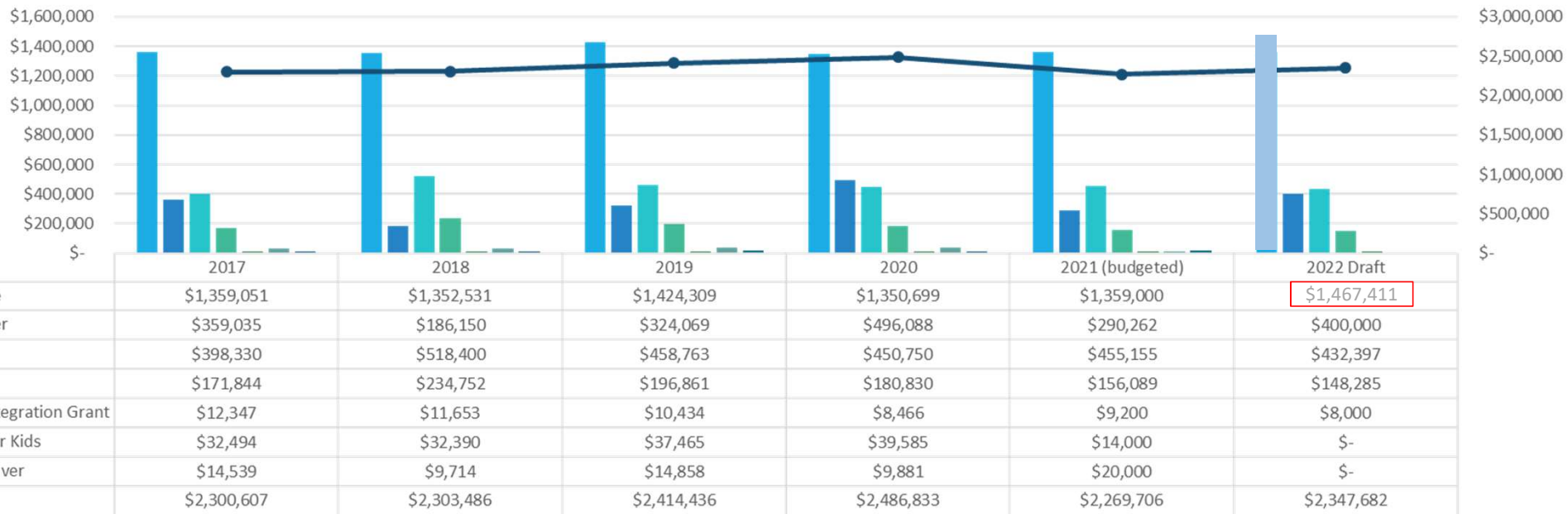

The table below shows actual revenue until 2020. 2021 and 2022 are budget.

How do we compare to other districts

Demographic	2019			2020 Students			
Grade				All Grades			
Category							
Org Name	Region	\$/In-district Pupil	Relative District Wealth*	Total Enrollment	Eco Dis %	SWD %	EL %
Barnstable	Southeast	\$17,104	118%	5,041	36.7%	17.0%	12.6%
Bourne	Southeast	\$15,919	109%	1,907	26.7%	17.1%	0.7%
Cape Cod Lighthouse	Southeast			239	16.3%	18.8%	0.8%
Cape Cod RVT	Southeast	\$28,713	175%	616	38.6%	28.2%	2.4%
Dennis-Yarmouth	Southeast	\$18,613	148%	2,912	43.6%	19.3%	10.9%
Falmouth	Southeast	\$18,333	148%	3,251	29.5%	18.2%	4.4%
Martha's Vineyard	Southeast	\$33,738	295%	670	29.9%	22.5%	10.9%
Mashpee	Southeast	\$18,324	140%	1,563	32.2%	15.5%	4.0%
Monomoy	Southeast	\$19,108	259%	1,876	28.7%	16.7%	4.9%
Nauset	Southeast	\$20,239	238%	1,480	21.0%	17.5%	1.9%
Provincetown	Southeast	\$45,272	833%	131	35.1%	19.1%	23.7%
Wellfleet	Southeast	\$33,775	328%	106	29.2%	19.4%	0.9%

General Fund Revenue and State Aid

The revenue included in the chart offsets the budget before the assessments are calculated.

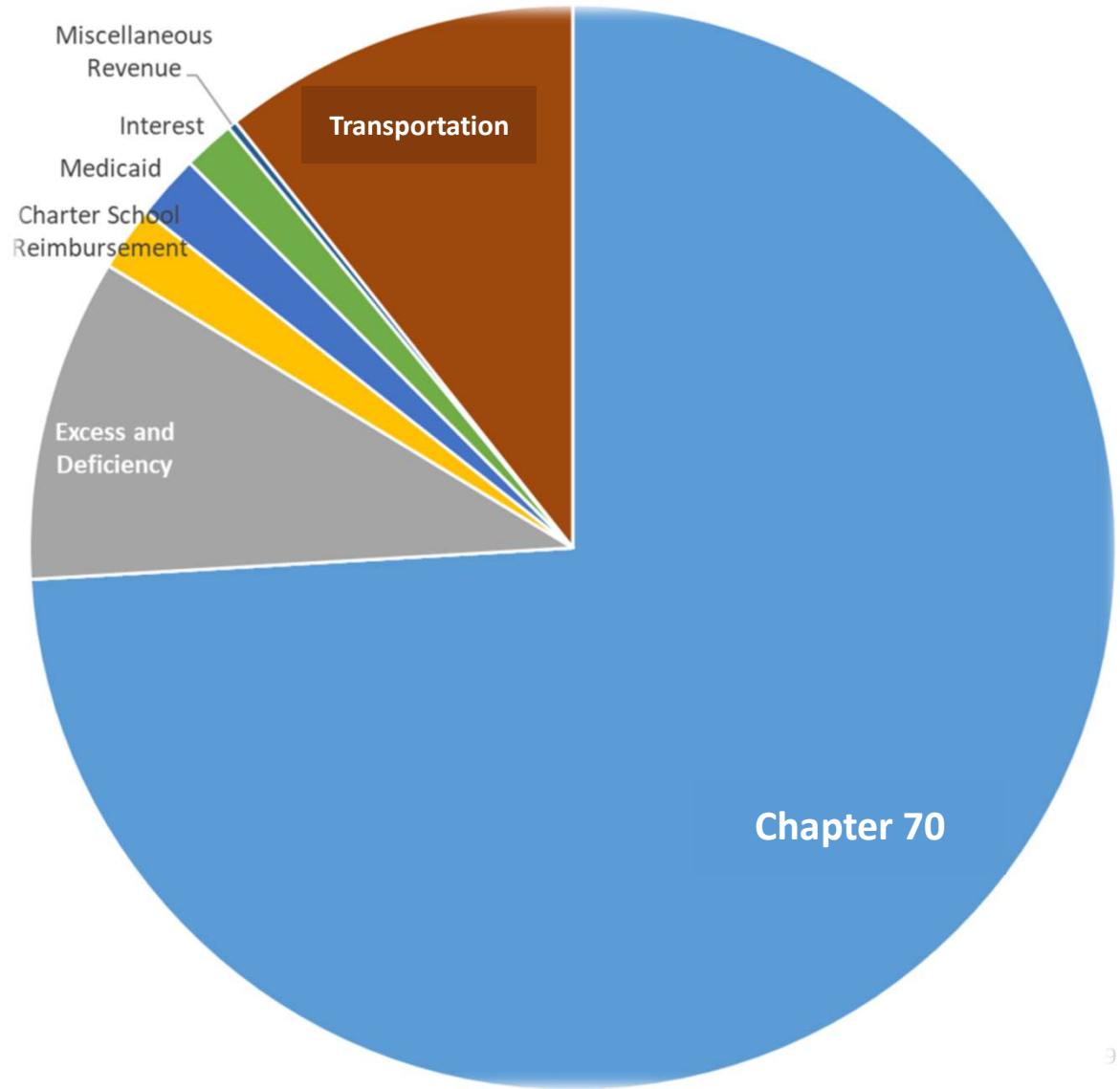

The last few years have seen a change in the required minimum contribution due to changes in the foundation enrollment in each Town.

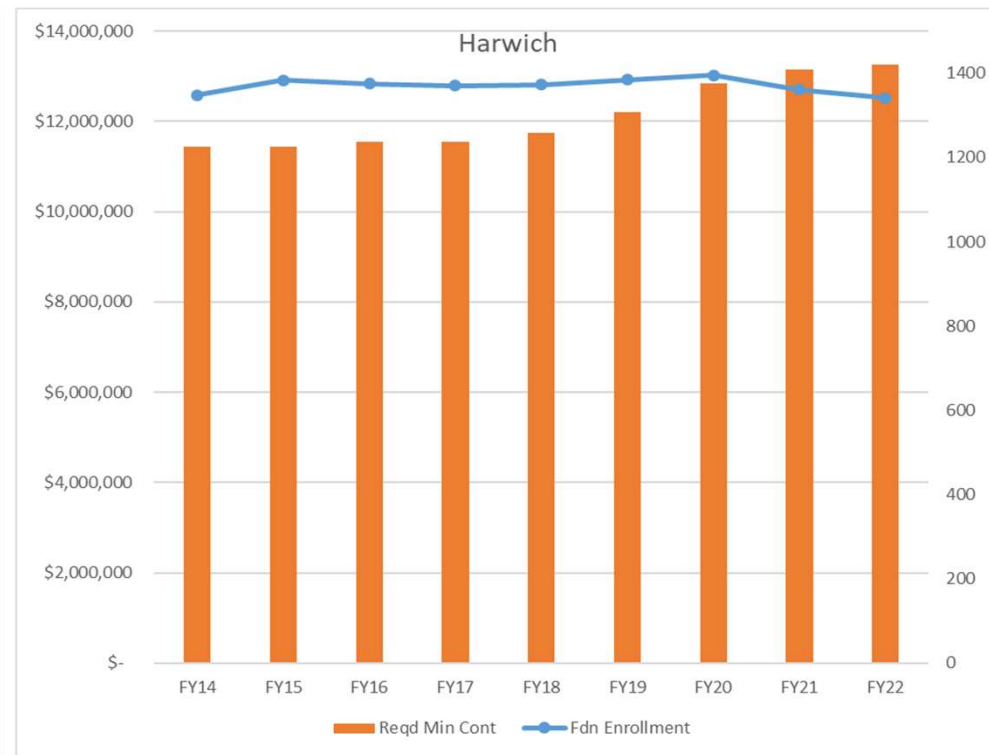
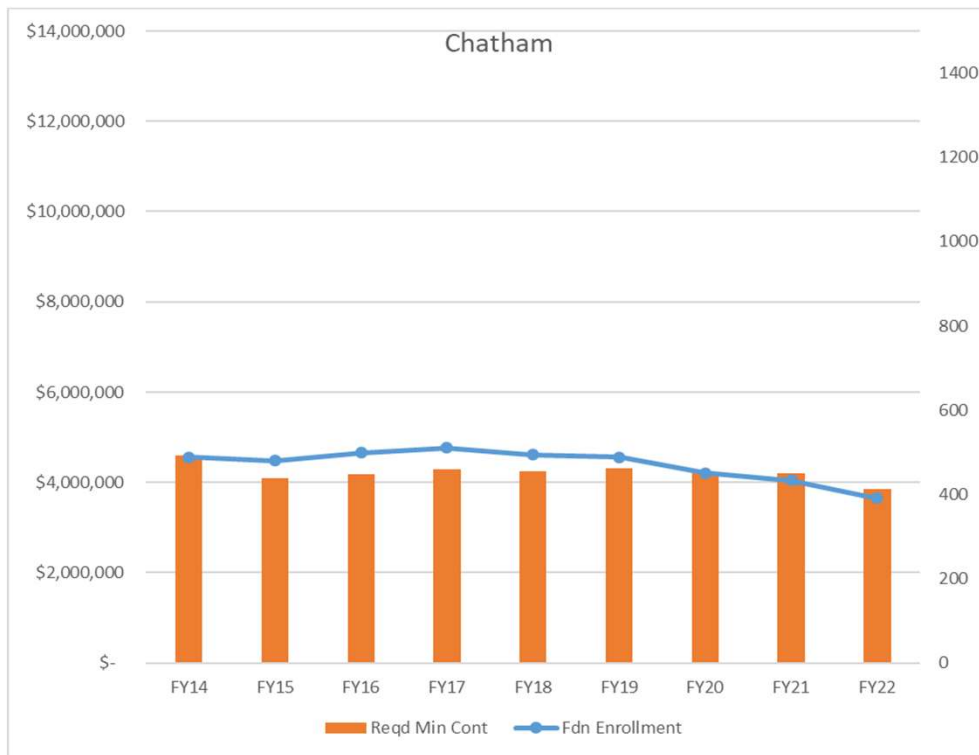

Assessment: Step 1 – calculation of budget

	FY22 Draft	Increase from FY21
Total Budget	\$41,561,134	\$300,000 (0.73%)

Step 2 – Forecast Offsets

Source	Forecast	Change from FY21
Chapter 70	\$3,850,274	\$51,960
Excess And Deficiency	\$800,000	-\$50,440
Charter School	\$100,028	\$24,311
Medicaid	\$100,000	-\$55,000
Interest	\$80,000	\$72,500
Misc Revenues	\$13,562	\$-
Transportation	\$731,525	\$90,165
General Fund Revenue and State Aid	\$5,675,389	\$133,496

Step 3 – Calculate Assessment

Assessment	Harwich	Change from FY21	Chatham	Change from FY21
Local Minimum Contribution	\$13,246,021	\$89,361	\$3,856,063	(\$334,506)
Operating assessment beyond minimum contribution	\$11,797,107	\$597,947	\$3,909,333	\$45,736
Transportation	\$591,564	(\$39,254)	\$187,219	(\$25,302)
Capital / Stabilization	\$273,260	\$9,317	\$90,553	(\$504)
Debt	\$1,453,097	(\$116,369)	\$481,528	(\$59,922)
Total	\$27,361,049	\$541,002 2.02%	\$8,524,696	(\$374,498) (4.21%)

DRAFT STATE BUDGET: ESSER GRANT FUNDING WILL CONTRIBUTE \$89,361 to HARWICH ASSESSMENT

Alternative Assessment Method?

Assessment	Basis	Harwich	Chatham
Local Minimum Contribution	State Calculation	\$13,246,021	\$3,856,063
Elementary School Cost	Budgeted amount + health insurance	\$7,289,180	\$3,091,234
Operating assessment beyond minimum contribution	3yr rolling average of foundation enrollment	\$4,000,378	\$1,325,648
Transportation	3yr rolling average of Oct 1 enrollment	\$591,564	\$187,219
Capital / Stabilization	3yr rolling average of foundation enrollment	\$273,260	\$90,553
Debt	3yr rolling average of foundation enrollment	\$1,453,097	\$481,528
Total		\$26,853,499	\$9,032,246
<i>Increase from FY21</i>		\$33,454 0.12%	\$133,050 1.5%

Chatham's assessment has fallen. Harwich's assessment initially fell but then grew in line with larger share of enrollment.

Year	Chatham - Expenditure/Assessment	Harwich - Expenditure/Assessment	Harwich Debt	Chatham Debt
FY07	\$ 8,632,234	\$ 17,792,682	n/a	n/a
FY08	\$ 8,942,774	\$ 18,142,837	n/a	n/a
FY09	\$ 9,506,570	\$ 18,321,416	n/a	n/a
FY10	\$ 10,329,247	\$ 19,441,649	n/a	n/a
FY11	\$ 10,108,138	\$ 20,386,086	n/a	n/a
FY12	\$ 9,886,548	\$ 19,922,717	n/a	n/a
FY13	\$ 8,119,684	\$ 19,679,682	\$ 60,281	\$ 222,373
FY14	\$ 7,615,764	\$ 20,337,662	\$ 89,812	\$ 203,246
FY15	\$ 7,739,657	\$ 20,070,183	\$ 569,017	\$ 210,459
FY16	\$ 8,207,932	\$ 22,843,944	\$ 1,821,719	\$ 651,762
FY17	\$ 8,632,592	\$ 24,058,302	\$ 1,776,772	\$ 634,699
FY18	\$ 8,941,137	\$ 24,759,749	\$ 1,708,359	\$ 616,572
FY19	\$ 9,210,686	\$ 25,609,390	\$ 1,636,241	\$ 597,535
FY20	\$ 9,138,886	\$ 26,643,415	\$ 1,658,018	\$ 599,325
FY21	\$ 8,899,195	\$ 26,820,046	\$ 1,569,466	\$ 541,450
FY22	\$ 8,626,350	\$ 27,667,807	\$ 1,453,097	\$ 481,528

This graph shows each Town's share of minimum local contribution, foundation enrollment and the assessment.

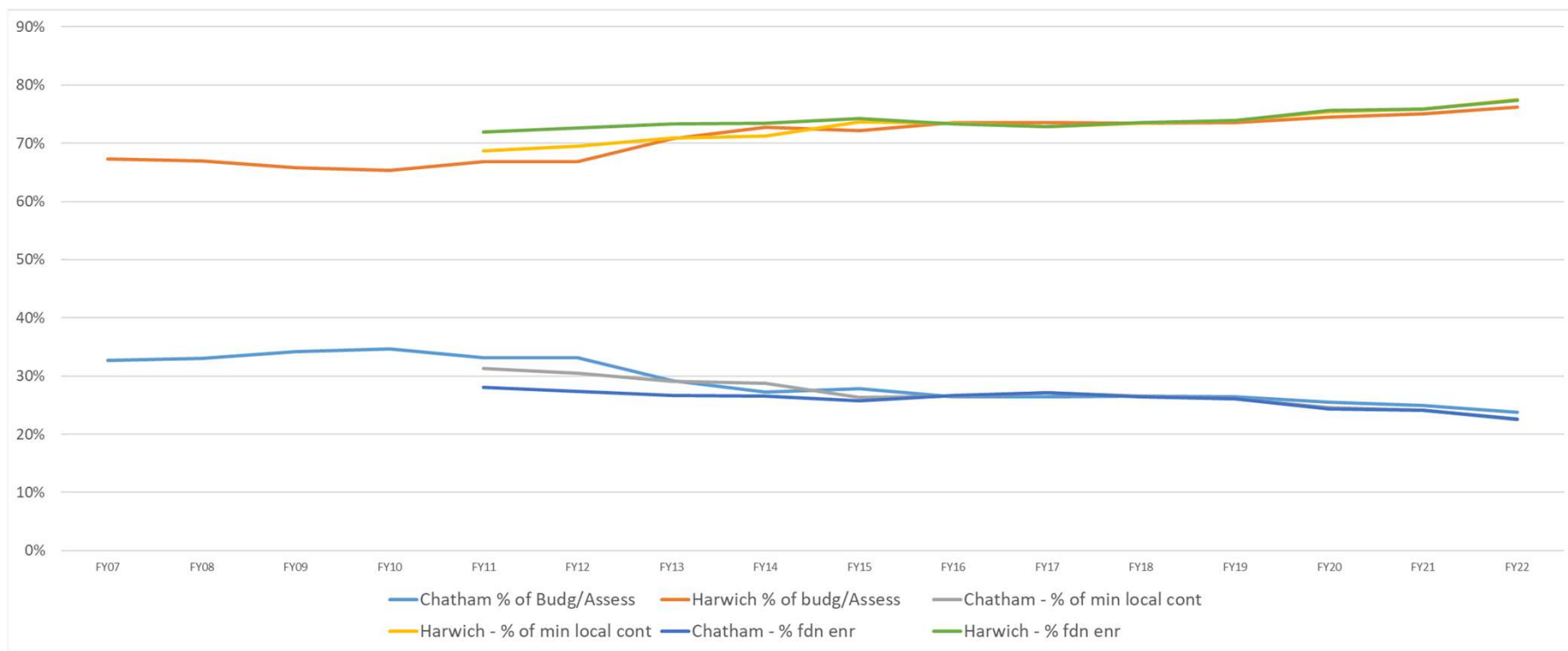

The timeline to regionalization includes step changes, year to year, from FY11 to FY14. Financial regionalization began in FY12.

- FY11: Harwich and Chatham vote to form Monomoy Regional at Special Town Meetings - December 6, 2010.
- FY12: Monomoy operates with a regionalized Central Office under a transitional superintendent (2 high schools, 2 middle schools, 2 elementary schools)
- FY13: Monomoy hires a superintendent to fully bring the new district together (2 high schools, 2 middle schools, 2 elementary schools)
- FY14: Monomoy fully regionalizes (1 high school, 1 middle school, 2 elementary schools)

Chatham's annual increase fell after regionalization.

With Post Regionalization Debt

Year	Chatham - Expenditure/Assessment	Change	% Change	Average Change
FY07	\$ 8,632,234			
FY08	\$ 8,942,774	\$ 310,540	3.6%	4.1%
FY09	\$ 9,506,570	\$ 563,796	6.3%	
FY10	\$ 10,329,247	\$ 822,677	8.7%	
FY11	\$ 10,108,138	\$ (221,109)	-2.1%	-1.2%
FY12	\$ 9,886,548	\$ (221,590)	-2.2%	
FY13	\$ 8,119,684	\$ (1,766,864)	-17.9%	
FY14	\$ 7,615,764	\$ (503,920)	-6.2%	
FY15	\$ 7,739,657	\$ 123,893	1.6%	
FY16	\$ 8,207,932	\$ 468,275	6.1%	
FY17	\$ 8,632,592	\$ 424,660	5.2%	
FY18	\$ 8,941,137	\$ 308,545	3.6%	
FY19	\$ 9,210,686	\$ 269,549	3.0%	
FY20	\$ 9,138,886	\$ (71,800)	-0.8%	
FY21	\$ 8,899,195	\$ (239,691)	-2.6%	
FY22	\$ 8,626,350	\$ (272,845)	-3.1%	

Excluding Post Regionalization Debt (apples to apples)

Year	Chatham - Expenditure/Assessment	Change	% Change	Average Change
FY07	\$ 8,632,234			
FY08	\$ 8,942,774	\$ 310,540	3.6%	4.1%
FY09	\$ 9,506,570	\$ 563,796	6.3%	
FY10	\$ 10,329,247	\$ 822,677	8.7%	
FY11	\$ 10,108,138	\$ (221,109)	-2.1%	-1.7%
FY12	\$ 9,886,548	\$ (221,590)	-2.2%	
FY13	\$ 7,897,311	\$ (1,989,237)	-20.1%	
FY14	\$ 7,412,518	\$ (484,793)	-6.1%	
FY15	\$ 7,529,198	\$ 116,680	1.6%	
FY16	\$ 7,556,170	\$ 26,972	0.4%	
FY17	\$ 7,997,893	\$ 441,723	5.8%	
FY18	\$ 8,324,565	\$ 326,672	4.1%	
FY19	\$ 8,613,151	\$ 288,586	3.5%	
FY20	\$ 8,539,561	\$ (73,590)	-0.9%	
FY21	\$ 8,357,745	\$ (181,816)	-2.1%	
FY22	\$ 8,144,822	\$ (212,923)	-2.5%	

For Harwich the average percentage increase in the budget was less after regionalization than it was before regionalization.

With Post Regionalization Debt

Year	Harwich - Budget / Assessment	Change	% Change	Average Change
FY07	\$ 17,792,682			
FY08	\$ 18,142,837	\$ 350,155	2.0%	3.5%
FY09	\$ 18,321,416	\$ 178,579	1.0%	
FY10	\$ 19,441,649	\$ 1,120,233	6.1%	
FY11	\$ 20,386,086	\$ 944,437	4.9%	
FY12	\$ 19,922,717	\$ (463,369)	-2.3%	2.9%
FY13	\$ 19,679,682	\$ (243,035)	-1.2%	
FY14	\$ 20,337,662	\$ 657,980	3.3%	
FY15	\$ 20,070,183	\$ (267,479)	-1.3%	
FY16	\$ 22,843,944	\$ 2,773,761	13.8%	
FY17	\$ 24,058,302	\$ 1,214,358	5.3%	
FY18	\$ 24,759,749	\$ 701,447	2.9%	
FY19	\$ 25,609,390	\$ 849,641	3.4%	
FY20	\$ 26,643,415	\$ 1,034,025	4.0%	
FY21	\$ 26,820,046	\$ 176,631	0.7%	
FY22	\$ 27,667,807	\$ 847,761	3.2%	

Excluding Post Regionalization Debt (apples to apples)

Year	Harwich Exp/Assess exl debt	Yr on Yr Increase	%Change	Average Change
FY07	\$ 17,792,682			
FY08	\$ 18,142,837	\$ 350,155	2.0%	3.5%
FY09	\$ 18,321,416	\$ 178,579	1.0%	
FY10	\$ 19,441,649	\$ 1,120,233	6.1%	
FY11	\$ 20,386,086	\$ 944,437	4.9%	
FY12	\$ 19,922,717	\$ (463,369)	-2.3%	2.4%
FY13	\$ 19,619,401	\$ (303,316)	-1.5%	
FY14	\$ 20,247,850	\$ 628,449	3.2%	
FY15	\$ 19,501,166	\$ (746,684)	-3.7%	
FY16	\$ 21,022,225	\$ 1,521,059	7.8%	
FY17	\$ 22,281,530	\$ 1,259,305	6.0%	
FY18	\$ 23,051,390	\$ 769,860	3.5%	
FY19	\$ 23,973,149	\$ 921,759	4.0%	
FY20	\$ 24,985,397	\$ 1,012,248	4.2%	
FY21	\$ 25,250,580	\$ 265,183	1.1%	
FY22	\$ 26,214,710	\$ 964,130	3.8%	

Monomoy Regional School District FY22 Budget

TOWN OF HARWICH PRESENTATION

March 24, 2021



Memo

To: Board of Selectmen

From: Joseph F. Powers, Town Administrator *JFP*

CC: Meggan M. Eldredge, Assistant Town Administrator
Carol Coppola, Finance Director

RE: Updated reference documents for the Draft Warrant

Date: March 24, 2021

Attached for your review are three documents for reference in your discussion this evening.

LATE ARTICLES FOR REVIEW BY COUNSEL

This document contains three capital articles for the Water Department that I inadvertently omitted from the previous draft. They have not been in any previous drafts and you are seeing them for the first time. The three articles have been vetted and reviewed by both Town Counsel and the Water Superintendent.

REVISED DRAFT WARRANT

This document updates the version in your packet in the following ways:

- Updated Articles
 - Articles # 9, 22, 40, & 41
- Corrected Articles
 - Article # 23
- Newly Added Articles
 - Articles # 24, 25, 26, & 54

Lastly, I incorrectly deleted a draft article on the Select Board language change. Given the Board has not taken action on that, it appears as article 54 in the revised draft.

REVISED SPREADSHEET

This spreadsheet has been updated to reflect the recent changes included in this memo.

New source exploration for town water supply

Article 24: To see if the Town if the Town will vote to appropriate from Certified Retained Earnings of the Water Enterprise Fund a sum of money to conduct new source exploration for the Town's water supply, including all costs incidental and related thereto; and to act fully thereon. By request of the Water and Wastewater Commission. Estimated Cost: \$250,000.00.

Explanation: The Water Department is seeking \$250,000 to conduct well exploration in North Harwich. Services rendered through this appropriation will include site review and mapping, installation of 2-inch & 4-inch test wells, well development and pump testing of 4-inch wells, and preparation of Mass DEP Request for Site Examination and Prolonged Test Pumping Proposal. Should a viable production well be identified a future appropriation will be required to install the final well casing and pump house.

FINANCE COMMITTEE RECOMMENDS THIS ARTICLE BE ACCEPTED AND ADOPTED. VOTE: YES-#, NO-#

ROLL CALL VOTES:

Finance Committee:

To accept and adopt:

Yeas: # (number): [Members by Roll Call]

Nays: # (number): [Members by Roll Call]

Board of Selectmen:

To accept and adopt:

Yeas: # (number): [Members by Roll Call]

Nays: # (number): [Members by Roll Call]

Route 28 Water Main Replacement Design

Article 25: To see if the Town if the Town will vote to appropriate from Certified Retained Earnings of the Water Enterprise Fund a sum of money for the design and engineering for the replacement of approximately 1.75 miles of water main replacement on Route 28 between Lower County Road and the Herring River Bridge, including all costs incidental and related thereto; and to act fully thereon. By request of the Water and Wastewater Commission. Estimated Cost: \$500,000.00.

Explanation: The Water Department is seeking \$500,000 for the purpose of preparing plans and specifications for the replacement of approximately 1.75 miles of water main on Route 28 from Lower County Road to the Herring River Bridge. The existing water was installed in the 1940's and is beyond its useful life and the subject of several water main breaks. This segment of water main also contains very few gate valves which requires as many as 25 valves to be closed to isolate and repair the water main after a break leaving larges sections of town without water during the repair. Should this article be approved a future appropriating will be required to complete the work.

FINANCE COMMITTEE RECOMMENDS THIS ARTICLE BE ACCEPTED AND ADOPTED. VOTE: YES-#, NO-#

ROLL CALL VOTES:

Finance Committee:

To accept and adopt:

Yeas: # (number): [Members by Roll Call]

Nays: # (number): [Members by Roll Call]

Board of Selectmen:

To accept and adopt:

Yeas: # (number): [Members by Roll Call]

Nays: # (number): [Members by Roll Call]

Station 8 Generator

Article 26: To see if the Town will vote to appropriate from Certified Retained Earnings of the Water Enterprise Fund a sum of money to purchase, equip, and install a new generator for Station 8, including all costs incidental and related thereto; and to act fully thereon. By request of the Water and Wastewater Commission. Estimated Cost: \$50,000.00.

Explanation: The Water Department is seeking funds to replace a 2005 Generac generator located at Station 8 which provides back-up power to Well #8 and the corrosion control facility on Bat Road. The generator has been in service for 16 years and can no longer be relied upon for back-up power.

FINANCE COMMITTEE RECOMMENDS THIS ARTICLE BE ACCEPTED AND ADOPTED. VOTE: YES-#, NO-#

ROLL CALL VOTES:

Finance Committee:

To accept and adopt:

Yeas: # (number): [Members by Roll Call]

Nays: # (number): [Members by Roll Call]

Board of Selectmen:

To accept and adopt:

Yeas: # (number): [Members by Roll Call]

Nays: # (number): [Members by Roll Call]

VOTING PROCEDURES

- I A quorum, 150 registered voters, must be present in order to conduct business. The only motion in order when no quorum is present is a motion to adjourn.
- II A two-thirds majority of the Town Meeting shall be required for inclusion of any Capital Outlay, unless it was included in the Capital Outlay Plan adopted at the preceding Town Meeting.
- III All motions introduced at the Town Meeting shall be in writing when required by the Moderator.
- IV Voters are limited to two times speaking on any one question; the total time speaking not to exceed 10 minutes.
- V Only registered voters shall occupy the meeting "floor".
- VI No voter will be allowed to speak until he or she is recognized by the Moderator.
- VII Motion requiring more than a simple majority to pass:
 - A. To reconsider a vote on a motion – $\frac{3}{4}$ majority (this motion must be made prior to the next adjournment of the meeting).
 - B. To consider articles in an order other than as appears on the warrant – $\frac{3}{4}$ majority.
 - C. To pay unpaid bills – $\frac{4}{5}$ majority at the Annual Town Meeting, $\frac{9}{10}$ majority at a Special Town Meeting.
 - D. To move the previous question (terminate debate) – $\frac{3}{4}$ majority.
- VIII Quorum cannot be questioned after a motion has been made and seconded.

MOTION CHART Section 1-211
(Application of Rules is indicated by an X)

Motions	Debatable	Non Debatable	Amendable	Non Amendable	Second Required	Second Not Required	Majority Vote	2/3 Vote	¼ Vote	May Reconsider	Cannot Reconsider
Adjourn		X		X	X		X				X
Adjourn (in a time certain)	X		X		X		X			X	
Amendment	X		X		X		X			X	
Adopt a Resolution	X		X		X		X				X
Accept & Adopt	X		X		X		X ¹			X	
Postpone Indefinitely	X			X	X		X			X	
Previous Question Terminate Debate		X		X	X			X			X
Reconsider ²	X			X	X			X			X
Consider Articles Out of Order	X		X		X			X			X
Point of Order		X								X	
1. Unless a greater than simple majority required by General Laws of Town of Harwich by-laws.											
2. See section 1.207											

2

TAX RATE CHART

THE CHART BELOW SHOWS THE AMOUNT OF MONEY REQUIRED TO CHANGE
THE FY 2022 TAX RATE

TAX RATE CHANGE IN \$/1000	DOLLARS REQUIRED
\$0.01	\$56,835
\$0.05	\$284,175
\$0.10	\$568,349
\$0.15	\$852,524
\$0.20	\$1,136,699
\$0.25	\$1,420,874
\$0.30	\$1,705,048
\$0.35	\$1,989,223
\$0.40	\$2,273,398
\$0.45	\$2,557,572
\$0.50	\$2,841,747
\$0.55	\$3,125,922
\$0.60	\$3,410,096
\$0.65	\$3,694,271
\$0.70	\$3,978,446
\$0.75	\$4,262,621
\$0.80	\$4,546,795
\$0.85	\$4,830,970
\$0.90	\$5,115,145
\$0.95	\$5,399,319
\$1.00	\$5,683,494

MUNICIPAL FINANCE TERMS

APPROPRIATION: An authorization granted by a town meeting, city council or other legislative body to expend money and incur obligations for specific public purposes. An appropriation is usually limited in amount and as to the time period within which it may be expended.

AVAILABLE FUNDS: Balances in the various fund types that represent nonrecurring revenue sources. As a matter of sound practice, they are frequently appropriated for unforeseen expenses, capital expenditures, or other one-time costs. Examples of available funds include free cash, stabilization funds, overlay surplus, water surplus, and retained earnings.

CHERRY SHEET: Named for the cherry-colored paper on which they were originally printed, the Cherry Sheet is the official notification to cities, towns, and regional school districts of the next fiscal year's state aid and assessments. The aid is in the form of distributions, which provide funds based on formulas and reimbursements that provide funds for costs incurred during a prior period for certain programs or services.

FREE CASH: Remaining, unrestricted funds from operations of the previous fiscal year, including unexpended free cash from the previous year, actual receipts in excess of revenue estimated on the tax recapitulation sheet, and unspent amounts in budget line items. Unpaid property taxes and certain deficits reduce the amount that can be certified as free cash.

OVERLAY (Overlay Reserve, or Allowance for Abatements and Exemptions): An account that funds anticipated property tax abatements, exemptions, and uncollected taxes. Additions to the overlay reserve need not be funded by the normal appropriation process but instead raised on the tax rate recapitulation sheet.

RESERVE FUND: An amount (not to exceed 5 percent of the tax levy for the preceding year) set aside annually within a community's budget to provide a funding source for extraordinary or unforeseen expenditures. In a town, the finance committee can authorize transfers from this fund for "extraordinary or unforeseen" expenditures. Other uses of the fund require budgetary transfers by town meeting.

STABILIZATION FUND: A fund designed to accumulate amounts for capital and other future spending purposes, although it may be appropriated for any lawful purpose (MGL c. 40 § 5B). Communities may establish one or more stabilization funds for different purposes and may appropriate any amounts into them. A two-thirds vote of town meeting is required to establish, amend the purpose of, or appropriate money from a stabilization fund. A majority vote of town meeting is required to appropriate money into a stabilization fund.

MUNICIPAL FINANCE TERMS RELATED TO CAPITAL IMPROVEMENTS

CAPITAL ASSETS: – Any tangible property used in the operation of government that is not easily converted into cash and that has an initial useful life extending beyond a single financial reporting period. Capital assets include land and land improvements; infrastructure, such as roads, bridges, water and sewer lines; easements; buildings and building improvements; vehicles, machinery and equipment. Communities typically define capital assets in terms of a minimum useful life and minimum initial cost.

CAPITAL BUDGET: An appropriation or spending plan that uses borrowing or direct outlay for capital or fixed asset improvements. Among other information, a capital budget should identify the method to finance each recommended expenditure (e.g., tax levy or rates) and identify those items that were not recommended.

CAPITAL IMPROVEMENTS PROGRAM: – A blueprint for planning a community's capital expenditures that comprises an annual capital budget and a five-year capital plan. It coordinates community planning, fiscal capacity, and physical development. While all the community's needs should be identified in the program, there is a set of criteria that prioritize the expenditures.

CAPITAL OUTLAY: The exchange of one asset (cash) for another (capital asset) with no ultimate effect on net assets. Also known as "pay as you go," it is the appropriation and use of available cash to fund a capital improvement, as opposed to incurring debt to cover the cost.

FIXED ASSETS: – Long-lived, tangible assets, such as buildings, equipment and land, obtained or controlled as a result of past transactions or circumstances.

MUNICIPAL FINANCE TERMS RELATED TO PROPOSITION 2 ½ TERMS

Chapter 59, Section 21C of the Massachusetts General Laws commonly referred to as Proposition 2 ½ (Prop. 2 ½) or the Tax Limiting Law for Cities and Towns in Massachusetts.

CAPITAL OUTLAY EXPENDITURE EXCLUSION: A temporary increase in the tax levy to fund a capital project or to make a capital acquisition. Such an exclusion requires a two-thirds vote of the selectmen or city council (sometimes with the mayor's approval) and a majority vote in a communitywide referendum. The exclusion is added to the tax levy only during the year in which the project is being funded and may increase the tax levy above the levy ceiling.

CONTINGENT APPROPRIATION: An appropriation that authorizes spending for a particular purpose only if subsequently approved in a voter referendum. Under MGL c. 59 § 21C (m), towns may make appropriations from the tax levy, available funds, or borrowing contingent on the subsequent passage of a Proposition 2½ override or exclusion question for the same purpose. If initially approved at an annual town meeting, voter approval of the contingent appropriation must occur by September 15. Otherwise, the referendum vote must occur within 90 days after the town meeting dissolves. The question may be placed before the voters at more than one election, but if the appropriation is not approved by the applicable deadline, it is null and void. If contingent appropriations are funded through

property taxes, DLS cannot approve the tax rate until the related override or exclusion question is resolved or the deadline passes, whichever occurs first.

DEBT EXCLUSION: An action taken by a community through a referendum vote to raise the funds necessary to pay debt service costs for a particular project from the property tax levy but outside of the limits under Proposition 2^{1/2}. By approving a debt exclusion, a community calculates its annual levy limit under Proposition 2^{1/2}, then adds the excluded debt service cost. The amount is added to the levy limit for the life of the debt only and may increase the levy above the levy ceiling.

LEVY: The amount a community raises through the property tax. The levy can be any amount up to the levy limit, which is reestablished every year in accordance with Proposition 2^{1/2} provisions.

LEVY CEILING: – A levy ceiling is one of two types of levy (tax) restrictions imposed by MGL c. 59 § 21C (Proposition 2^{1/2}). It states that, in any year, the real and personal property taxes imposed may not exceed 2^{1/2} percent of the total full and fair cash value of all taxable property. Property taxes levied may exceed this limit only if the community passes a capital exclusion, debt exclusion, or special exclusion.

LEVY LIMIT: A levy limit is one of two types of levy (tax) restrictions imposed by MGL c. 59 § 21C (Proposition 2^{1/2}). It states that the real and personal property taxes imposed by a city or town may only grow each year by 2^{1/2} percent of the prior year's levy

NEW GROWTH: The additional tax revenue generated by new construction, renovations and other increases in the property tax base during a calendar year. It does not include value increases caused by normal market forces or revaluations.

OVERRIDE: A vote by a community at an election to permanently increase the levy limit. An override vote may increase the levy limit no higher than the levy ceiling. The override question on the election ballot must state a purpose for the override and the dollar amount.

OVERRIDE CAPACITY: The difference between a community's levy ceiling and its levy limit. It is the maximum amount by which a community may override its levy limit.

Note: The glossary definitions found on pages 4, 5 and 6 of this Warrant were derived from the *Municipal Glossary* published the Division of Local Services (January 2020).

The entire glossary can be found at:

<https://www.mass.gov/info-details/municipal-governance-training-and-resources>

**COMMONWEALTH OF MASSACHUSETTS
TOWN OF HARWICH
ANNUAL TOWN MEETING
May 8, 2021**

BARNSTABLE, ss:

To either of the Constables of the Town of Harwich in said county,

Greetings:

In the name of the Commonwealth of Massachusetts you are hereby directed to notify and warn the inhabitants of said Town qualified to vote in elections and Town affairs to meet at the Monomoy Regional High School Stadium Field, 75 Oak Street in said Town on Saturday, May 8, 2021 at 10:00 A.M., then and there to act on the following articles:

ARTICLES

TOWN OFFICERS AND COMMITTEES

ARTICLE 1: To choose various Town Officers and Committees.

FINANCE COMMITTEE RECOMMENDS THIS CUSTOMARY ARTICLE BE ACCEPTED AND ADOPTED. VOTE: YES-#, NO-#

ROLL CALL VOTES:

Finance Committee:

To accept and adopt:

Yeas: # (number): [Members by Roll Call]

Nays: # (number): [Members by Roll Call]

Board of Selectmen:

To accept and adopt:

Yeas: # (number): [Members by Roll Call]

Nays: # (number): [Members by Roll Call]

REPORTS OF TOWN OFFICERS AND COMMITTEES

ARTICLE 2: To hear reports of all Town Officers and Committees for the year 2020.

FINANCE COMMITTEE RECOMMENDS THIS CUSTOMARY ARTICLE BE ACCEPTED AND ADOPTED. VOTE: YES-#, NO-#

ROLL CALL VOTES:

Finance Committee:

To accept and adopt:

Yeas: # (number): [Members by Roll Call]

Nays: # (number): [Members by Roll Call]

Board of Selectmen:

To accept and adopt:

Yeas: # (number): [Members by Roll Call]

Nays: # (number): [Members by Roll Call]

ELECTED OFFICIALS SALARIES

ARTICLE 3: To see if the Town will vote the salaries of the Elected Officials of the Town for fiscal year commencing July 1, 2021 and ending June 30, 2022 as follows and to act fully thereon. Estimated cost: \$118,503.00.

Selectmen (5)	\$2,400 each
Moderator	\$1,000
Water & Wastewater Commissioners (5)	\$1,000 each
Library Trustees (7)	\$1,000 each
Town Clerk	\$103,503

FINANCE COMMITTEE RECOMMENDS THIS ARTICLE BE ACCEPTED AND ADOPTED. VOTE: YES-#, NO-#

ROLL CALL VOTES:

Finance Committee:

To accept and adopt:

Yeas: # (number): [Members by Roll Call]

Nays: # (number): [Members by Roll Call]

Board of Selectmen:

To accept and adopt:

Yeas: # (number): [Members by Roll Call]

Nays: # (number): [Members by Roll Call]

TOWN OPERATING BUDGET

ARTICLE 4: To see if the Town will vote to raise and appropriate, transfer from available funds or borrow such sums of money as may be required to defray Town charges for Fiscal Year 2022, and to act fully thereon. By request of the Board of Selectmen. (BUDGET – APPENDIX B). Estimated Cost: \$39,027,463.00.

OPERATING BUDGET	
Betterments	\$61,287
Cable Fund	\$210,100
Community Preservation Act (CPA)	\$233,050
FEMA	\$13,855
Free Cash	\$560,331
Golf Improvement	\$104,950
Overlay Surplus	\$200,000
State Aid	\$667,067
Water Enterprise	\$727,304
Wastewater Enterprise	\$31,446
SUBTOTAL	\$2,809,390
Local Receipts	\$12,680,198
Taxes	\$23,537,875
OPERATING BUDGET	\$39,027,463

FINANCE COMMITTEE RECOMMENDS THIS ARTICLE BE ACCEPTED AND ADOPTED. VOTE: YES-#, NO-#

ROLL CALL VOTES:

Finance Committee:

To accept and adopt:

Yeas: # (number): [Members by Roll Call]

Nays: # (number): [Members by Roll Call]

Board of Selectmen:

To accept and adopt:

Yeas: # (number): [Members by Roll Call]

Nays: # (number): [Members by Roll Call]

MONOMOY REGIONAL SCHOOL DISTRICT BUDGET

ARTICLE 5: To see if the Town will vote to raise and appropriate, transfer from available funds or borrow such sums of money as may be required to pay for the Monomoy Regional School District Assessment for Fiscal Year 2022, and to act fully thereon. By request of the Monomoy Regional School Committee. Estimated cost: \$27,361,049.00.

MONOMOY REGIONAL SCHOOL DISTRICT BUDGET	
Operating Budget	\$25,043,128
Transportation	\$591,564
Capital	\$273,260
Debt	\$1,453,097
TOTAL	\$27,361,049

FINANCE COMMITTEE RECOMMENDS THIS ARTICLE BE ACCEPTED AND ADOPTED. VOTE: YES-#, NO-#

ROLL CALL VOTES:

Finance Committee:

To accept and adopt:

Yeas: # (number): [Members by Roll Call]

Nays: # (number): [Members by Roll Call]

Board of Selectmen:

To accept and adopt:

Yeas: # (number): [Members by Roll Call]

Nays: # (number): [Members by Roll Call]

CAPE COD REGIONAL TECHNICAL SCHOOL DISTRICT BUDGET

ARTICLE 6: To see if the Town will vote to raise and appropriate, transfer from available funds or borrow a sufficient sum of money as may be required to pay for the Cape Cod Regional Technical High School District Assessment for Fiscal Year 2021, and to act fully thereon. By request of the Cape Cod Regional Technical High School District. Estimated cost: \$1,536,309.00.

CAPE COD REGIONAL TECHNICAL SCHOOL DISTRICT BUDGET	
Operating Budget	\$1,026,670
Debt	\$509,639
TOTAL	\$1,536,309

FINANCE COMMITTEE RECOMMENDS THIS ARTICLE BE ACCEPTED AND ADOPTED. VOTE: YES-#, NO-#

ROLL CALL VOTES:

Finance Committee:

To accept and adopt:

Yeas: # (number): [Members by Roll Call]

Nays: # (number): [Members by Roll Call]

Board of Selectmen:

To accept and adopt:

Yeas: # (number): [Members by Roll Call]

Nays: # (number): [Members by Roll Call]

WATER DEPARTMENT BUDGET

ARTICLE 7: To see if the Town will vote to raise and appropriate, transfer from available funds or borrow such sums of money as may be required to defray the Water Department Operating Budget for Fiscal Year 2022, and to act fully thereon. By request of the Water and Wastewater Commission. Estimated cost: \$4,223,405.00.

WATER OPERATING BUDGET	
Salaries	\$1,279,529
Expenses	\$1,462,195
Debt	\$704,377
Indirect Costs	\$727,304
OPEB	\$50,000
TOTAL	\$4,223,405

FINANCE COMMITTEE RECOMMENDS THIS ARTICLE BE ACCEPTED AND ADOPTED. VOTE: YES-#, NO-#

ROLL CALL VOTES:

Finance Committee:

To accept and adopt:

Yeas: # (number): [Members by Roll Call]

Nays: # (number): [Members by Roll Call]

Board of Selectmen:

To accept and adopt:

Yeas: # (number): [Members by Roll Call]

Nays: # (number): [Members by Roll Call]

WASTEWATER DEPARTMENT BUDGET

ARTICLE 8: To see if the Town will vote to raise and appropriate, transfer from available funds or borrow such sums of money as may be required to defray the Wastewater Department Operating Budget for Fiscal Year 2022, and to act fully thereon. By request of the Water and Wastewater Commission. Estimated cost: \$515,331.00.

WASTEWATER OPERATING BUDGET	
Salaries	\$78,099
Expenses	\$405,786
Indirect Costs	\$31,446
TOTAL	\$515,331

FINANCE COMMITTEE RECOMMENDS THIS ARTICLE BE ACCEPTED AND ADOPTED. VOTE: YES-#, NO-#

ROLL CALL VOTES:

Finance Committee:

To accept and adopt:

Yeas: # (number): [Members by Roll Call]

Nays: # (number): [Members by Roll Call]

Board of Selectmen:

To accept and adopt:

Yeas: # (number): [Members by Roll Call]

Nays: # (number): [Members by Roll Call]

Public, Education & Government (PEG) Access and Cable Related Fund for Public Access

Article 9: To see if the Town will vote to transfer from the PEG Access and Cable Related Funds such sums of money that may be required for the purpose of funding the public access station, Cape Cod Community Media Center, 17 Shad Hole Road, Dennis Port, MA 02639, providing the public access television to citizens of Harwich. Said funds are paid by Comcast to the Town for, and restricted to, use for local programming operations subject and pursuant to MGL c. 44 § 53F ¾; and to act fully thereon. By request of the Board of Selectmen. Estimated cost: \$150,994.00.

Explanation: To be funded from the PEG Access and Cable Related Fund. The Town of Harwich receives funding from Comcast subscriber fees to fund and maintain Public, Education, and Government television stations (PEG access) and which may be used only for such local programming purposes. Under a new cable license agreement with Comcast the Town will allocate funds directly to Cape Cod Community Media Center. The funding was previously paid directly from Comcast to Cape Cod Community Media Center to provide local and regional programming as well as access to equipment, training, use of local channels for the benefit of Harwich residents and the Town. The appropriation sum has been based on FY20 actual revenue paid by Comcast into the fund.

FINANCE COMMITTEE RECOMMENDS THIS ARTICLE BE ACCEPTED AND ADOPTED. VOTE: YES-#, NO-#

ROLL CALL VOTES:

Finance Committee:

To accept and adopt:
Yeas: # (number): [Members by Roll Call]
Nays: # (number): [Members by Roll Call]

Board of Selectmen:

To accept and adopt:
Yeas: # (number): [Members by Roll Call]
Nays: # (number): [Members by Roll Call]

Lease Purchase Agreements

ARTICLE 10: To see if the Town will vote to enter into various lease purchase financing agreements for town equipment included in the operating budget for FY 2022, said leases may be for a term not to exceed the useful life of the equipment as determined by the Board of Selectmen; or to act fully thereon. By request of the Board of Selectmen.

Explanation:

The Municipal Modernization Act of 2016 allows the Town to enter into a tax exempt lease purchase agreement for a period in excess of three years as a means of financing equipment purchases. The statute requires a recommendation by the Town Administrator and a two-thirds vote of Town Meeting.

FINANCE COMMITTEE RECOMMENDS THIS ARTICLE BE ACCEPTED AND ADOPTED. VOTE: YES-#, NO-#

ROLL CALL VOTES:

Finance Committee:

To accept and adopt:
Yeas: # (number): [Members by Roll Call]
Nays: # (number): [Members by Roll Call]

Board of Selectmen:

To accept and adopt:
Yeas: # (number): [Members by Roll Call]
Nays: # (number): [Members by Roll Call]

Adopt the Capital Plan

ARTICLE 11: To see if the Town will vote to adopt the Capital Plan for the ensuing five year period as proposed by the Board of Selectmen and set forth below or as amended by vote of the Town Meeting, and to act fully thereon. By request of the Board of Selectmen.

CAPITAL PLAN (APPENDIX C)

Explanation: Sections 5 and 6 of Chapter 9 of the Harwich Charter were amended by the voters at the 2020 Annual Town Election. Article 33 of this Town Meeting will codify the intent of Article 36 from the 2019 Annual Town Meeting to establish a Five (5) Year Capital

Plan. At the direction of the Town Administrator, the Capital Outlay Committee established a Five (5) Year Plan covering Fiscal Years 2022 through 2026 for adoption at this Town Meeting.

FINANCE COMMITTEE RECOMMENDS THIS ARTICLE BE ACCEPTED AND ADOPTED. VOTE: YES-#, NO-#

ROLL CALL VOTES:

Finance Committee:

To accept and adopt:

Yeas: # (number): [Members by Roll Call]

Nays: # (number): [Members by Roll Call]

Board of Selectmen:

To accept and adopt:

Yeas: # (number): [Members by Roll Call]

Nays: # (number): [Members by Roll Call]

Capital Items Funded From Free Cash – Items under \$50,000

ARTICLE 12: To see if the Town will vote to raise and appropriate, transfer from available funds or borrow a sufficient sum of money to fund the items in the table below included in the FY 2022 Capital Plan, and to act fully thereon. By request of the Board of Selectmen. Estimated cost: \$18,000.00

Department	Description	Amount
Police	Digital Fingerprint Machine (regular replacement)	\$18,000.00

Explanation:

FINANCE COMMITTEE RECOMMENDS THIS ARTICLE BE ACCEPTED AND ADOPTED. VOTE: YES-#, NO-#

ROLL CALL VOTES:

Finance Committee:

To accept and adopt:

Yeas: # (number): [Members by Roll Call]

Nays: # (number): [Members by Roll Call]

Board of Selectmen:

To accept and adopt:

Yeas: # (number): [Members by Roll Call]

Nays: # (number): [Members by Roll Call]

Funds for support of ADA-compliant sidewalks through Harwich Center

ARTICLE 13: To see if the Town will vote to raise and appropriate, transfer from available funds, or borrow a sufficient sum of money for the engineering and surveying services necessary for the preparation of plans and bid processes for proposed sidewalks from the Community Center to the Cultural Center; and to act fully thereon. By request of the Board of Selectmen and the Capital Outlay Committee. Estimated cost: \$50,000.00

Explanation: This article resumes efforts to develop ADA-compliant sidewalks from Center (Community Center) to Center (Cultural Center) via Harwich Center. The town will pursue a Community Development Block Grant (CDBG) in FY 2022 when the grant program resumes. The funds from this article will support the necessary site plan design and preparations as well as initial bid process costs in anticipation of receiving a CDBG grant. This article builds upon the grant of \$142,021 received on March 3, 2021 from MA DOT Shared Streets Emergency Grant Program.

FINANCE COMMITTEE RECOMMENDS THIS ARTICLE BE ACCEPTED AND ADOPTED. VOTE: YES-#, NO-#

ROLL CALL VOTES:

Finance Committee:

To accept and adopt:

Yeas: # (number): [Members by Roll Call]

Nays: # (number): [Members by Roll Call]

Board of Selectmen:

To accept and adopt:

Yeas: # (number): [Members by Roll Call]

Nays: # (number): [Members by Roll Call]

Sidewalks from Saquatucket Harbor to Harwich Port

ARTICLE 14: To see if the Town will vote to raise and appropriate, transfer from available funds, or borrow a sufficient sum of money to restore funds for the Walkway Design & Construction Project from Saquatucket Harbor to Harwich Port; and to act fully thereon. By request of the Board of Selectmen and the Capital Outlay Committee. Estimated cost: \$200,000.00

Explanation: This articles restores most of the \$250,000.00 that was voted at the 2018 Annual Town Meeting and returned to the Town to offset a budget deficit exacerbated by COVID-19. The town recently received approval from the Commonwealth of Massachusetts' Department of Transportation to proceed with this project. This article supplements a gift to the town in support of this much-needed and oft-delayed project.

FINANCE COMMITTEE RECOMMENDS THIS ARTICLE BE ACCEPTED AND ADOPTED. VOTE: YES-#, NO-#

ROLL CALL VOTES:

Finance Committee:

To accept and adopt:

Yeas: # (number): [Members by Roll Call]

Nays: # (number): [Members by Roll Call]

Board of Selectmen:

To accept and adopt:

Yeas: # (number): [Members by Roll Call]

Nays: # (number): [Members by Roll Call]

Funds for the MS4 Mandated Stormwater Permitting and Management Program

ARTICLE 15: To see if the Town will vote to raise and appropriate, transfer from available funds, or borrow a sufficient sum of money to support the town's local stormwater permitting and program management; and to act fully thereon. By request of the Board of Selectmen and Capital Outlay Committee. Estimated cost: \$200,000.00.

Explanation: The articles funds the costs necessary for the ongoing stormwater permitting and management program as required by the MassDEP MS4 program.

FINANCE COMMITTEE RECOMMENDS THIS ARTICLE BE ACCEPTED AND ADOPTED. VOTE: YES-#, NO-#

ROLL CALL VOTES:

Finance Committee:

To accept and adopt:

Yeas: # (number): [Members by Roll Call]

Nays: # (number): [Members by Roll Call]

Board of Selectmen:

To accept and adopt:

Yeas: # (number): [Members by Roll Call]

Nays: # (number): [Members by Roll Call]

Brooks Free Library roof replacement

ARTICLE 16: To see if the Town will vote to raise and appropriate, transfer from available funds, or borrow a sufficient sum of money to repair and/or replace the Brooks Free Library roof; and to act fully thereon. By request of the Board of Selectmen. Estimated cost: \$148,500.00.

Explanation: The Brooks Free Library's roof was last updated in 1997 with 20-year shingles. This project was originally submitted for the FY 2020 Capital Plan and was deferred in FY 2021. The estimated costs at that time were \$135,000.00. This request assumes a 10% increase in costs of materials and prevailing wage rates on installation.

FINANCE COMMITTEE RECOMMENDS THIS ARTICLE BE ACCEPTED AND ADOPTED. VOTE: YES-#, NO-#

ROLL CALL VOTES:

Finance Committee:

To accept and adopt:

Yeas: # (number): [Members by Roll Call]

Nays: # (number): [Members by Roll Call]

Board of Selectmen:

To accept and adopt:

Yeas: # (number): [Members by Roll Call]

Nays: # (number): [Members by Roll Call]

Funds for roof repairs at 5 Bells Neck Road

ARTICLE 17: To see if the Town will vote to raise and appropriate, transfer from available funds, or borrow a sufficient sum of money to make necessary repairs to the roof of the building at 5 Bells Neck Road; and to act fully thereon. By request of the Board of Selectmen and the Capital Outlay Committee. Estimated cost: \$50,000.00.

Explanation: This article was deferred in FY 2021 due to the impact of COVID-19 on the overall budget process. The town is currently developing a "Request for Proposal (RFP)" for the sale pending the adoption of Article 42 at this Town Meeting which will rescind previous votes to lease and authorizing the Board of Selectmen to sell 5 Bells Neck Road as surplus property.

FINANCE COMMITTEE RECOMMENDS THIS ARTICLE BE ACCEPTED AND ADOPTED. VOTE: YES-#, NO-#

ROLL CALL VOTES:

Finance Committee:

To accept and adopt:

Yeas: # (number): [Members by Roll Call]

Nays: # (number): [Members by Roll Call]

Board of Selectmen:

To accept and adopt:

Yeas: # (number): [Members by Roll Call]

Nays: # (number): [Members by Roll Call]

Public safety radios

ARTICLE 18: To see if the Town will vote to raise and appropriate, transfer from available funds, or borrow a sufficient sum of money to purchase radios for the Fire Department and Police Department; and to act fully thereon. By request of the Board of Selectmen and the Capital Outlay Committee. Estimated cost: \$223,204.00.

Explanation: The radios used by both public safety departments need to be upgraded in conformity with state standards. The anticipated cost for the Police Department radios is \$74,165.00 and for the Fire Department is \$149,039.00 for a total radio replacement cost of \$223,204.00. The Fire Department has applied for a grant FY 2022 from the Commonwealth of MA to offset costs related to this mandated upgrade.

FINANCE COMMITTEE RECOMMENDS THIS ARTICLE BE ACCEPTED AND ADOPTED. VOTE: YES-#, NO-#

ROLL CALL VOTES:

Finance Committee:

To accept and adopt:

Yeas: # (number): [Members by Roll Call]

Nays: # (number): [Members by Roll Call]

Board of Selectmen:

To accept and adopt:

Yeas: # (number): [Members by Roll Call]

Nays: # (number): [Members by Roll Call]

Purchase of a combination Pumper/Ladder Fire Truck

ARTICLE 19: To see if the Town will vote to raise and appropriate, transfer from available funds, or borrow a sufficient sum of money to fund the purchase of combination pumper/ladder fire truck known as a Quint, and all costs incidental and related thereto. The appropriation authorized by this vote shall not take effect until the Town votes to exempt from the limitation on total taxes imposed by M.G.L. c.59 § 21c (Proposition 2 ½) the amounts required to pay the principal of and the interest on any borrowing authorized under this article. And further, in accordance with Chapter 44, Section 20 of the General Laws, the premium received by the Town upon the sale of any bonds or notes thereunder, less any such premium applied to the payment of the costs of issuance of such bonds or notes, may be applied to pay project costs and the amount authorized to be borrowed for each such project shall be reduced by the amount of any such premium so applied, and to act fully thereon. By request of the Board of Selectmen and Capital Outlay Committee. Estimated cost: \$1,138,000.00.

Explanation: The fire department, in an effort to relieve some financial pressure on the capital budget in FY 2020 and 2021, offered the following modification of the Capital plan:

Remove the Engine replacement in FY20, accelerate the Ladder replacement in FY24 and purchase a Quint, a vehicle that performs the functions of a ladder and an Engine in FY21. By the time the FY21 budget was being prepared, the estimated cost of the quint had risen to 1.1 million. The manufacturer has indicated that another price increase will happen this month, and the new estimate is \$1,138,500.00. We are working with the representative and reviewing the specifications in the hopes of reducing that number. The passage of a debt exclusion ballot question #1 at the Annual Town Election on Tuesday, May 18, 2021 is also necessary for the purchase of this item.

FINANCE COMMITTEE RECOMMENDS THIS ARTICLE BE ACCEPTED AND ADOPTED. VOTE: YES-#, NO-#

ROLL CALL VOTES:

Finance Committee:

To accept and adopt:

Yeas: # (number): [Members by Roll Call]

Nays: # (number): [Members by Roll Call]

Board of Selectmen:

To accept and adopt:

Yeas: # (number): [Members by Roll Call]

Nays: # (number): [Members by Roll Call]

Fund the FY 2022 Road Maintenance Program

ARTICLE 20: To see if the Town will vote to raise and appropriate, transfer from available funds, or borrow a sufficient sum of money to fund the Road Maintenance Program, and all costs incidental and related thereto. The appropriation authorized by this vote shall not take effect until the Town votes to exempt from the limitation on total taxes imposed by M.G.L. c.59 § 21c (Proposition 2 ½) the amounts required to pay the principal of and the interest on any borrowing authorized under this article. And further, in accordance with Chapter 44, Section 20 of the General Laws, the premium received by the Town upon the sale of any bonds or notes thereunder, less any such premium applied to the payment of the costs of issuance of such bonds or notes, may be applied to pay project costs and the amount authorized to be borrowed for each such project shall be reduced by the amount of any such premium so applied, and to act fully thereon. By request of the Board of Selectmen and the Capital Outlay Committee. Estimated cost: \$700,000.00.

Explanation: The capital request for road maintenance for FY 2022 is \$700,000.00. The town anticipates receiving a similar amount from Chapter 90 funds from the Commonwealth. The town's Chapter 90 apportionment for FY 2021 is \$676,736.00. There is a debt exclusion ballot question #2 regarding this article on the Annual Town Election ballot to be voted on May 18, 2021.

FINANCE COMMITTEE RECOMMENDS THIS ARTICLE BE ACCEPTED AND ADOPTED. VOTE: YES-#, NO-#

ROLL CALL VOTES:

Finance Committee:

To accept and adopt:

Yeas: # (number): [Members by Roll Call]

Nays: # (number): [Members by Roll Call]

Board of Selectmen:

To accept and adopt:

Yeas: # (number): [Members by Roll Call]

Nays: # (number): [Members by Roll Call]

Purchase and Equip Vehicles for the Department of Public Works

Article 21: To see if the Town will vote to raise and appropriate, transfer from available funds, or borrow a sufficient sum of money to purchase and equip the vehicles listed in the table below and further to authorize the Board of Selectmen to dispose of the vehicles listed in the table below if determined to be surplus property; and to act fully thereon. By request of the Board of Selectmen. Estimated cost: \$460,000.00.

Purchase and Equip Vehicles	
VEHICLE TYPE	ANTICIPATED COST
Front-End Loader	\$200,000.00
6 Wheel Dump Truck or equivalent	\$175,000.00
Ford F-150 Pickup Truck or equivalent	\$50,000.00
Ford E-250 Van or equivalent	\$35,000.00
TOTAL COST	\$460,000.00

Vehicles to be disposed of if determined to be surplus
1991 Elgin Premier
1996 L-70C Front End Loader
2005 Ford F-150
2006 Ford E-250 Van

Explanation: The 1999 Sterling Dump Truck is becoming extremely difficult to find parts for due to its age and the parts we do get are extremely expensive. The front end loader has over 30,000 hours of use or the equivalent of 1,200,000 miles on it. It has been a solid piece of equipment and served the Town well, but it is time to replace it. This is a front line piece of equipment that is used 362 days per year at the Disposal Area and helps generate the \$3.3M in revenue. The average yearly maintenance cost has been \$21,748, indicating that it is time to remove this loader from front line work. The 2005 F-150 is at the end of its useful life and has 191,102 miles on it. The frame on this 16 year old vehicle is rotted through and may not pass State safety inspections any longer. The 2006 Ford E-250 Building Maintenance van floors and body panels are rusted through. It is questionable whether it will pass a safety inspection this year.

FINANCE COMMITTEE RECOMMENDS THIS ARTICLE BE ACCEPTED AND ADOPTED. VOTE: YES-#, NO-#

ROLL CALL VOTES:

Finance Committee:

To accept and adopt:

Yeas: # (number): [Members by Roll Call]

Nays: # (number): [Members by Roll Call]

Board of Selectmen:

To accept and adopt:

Yeas: # (number): [Members by Roll Call]

Nays: # (number): [Members by Roll Call]

Public, Education & Government (PEG) Access and Cable Related Fund for Hearing Room & Studio Improvements

Article 22: To see if the Town will vote to transfer from the PEG Access and Cable Related Fund such sums of money that may be required to purchase and install studio cameras, lighting, video production hardware/software, and network peripherals in multiple Town Hall and other municipal hearing room locations for improved public meeting coverage subject and pursuant to MGL c. 44 § 53F ¾; and to act fully thereon. By request of the Board of Selectmen. Estimated Cost: \$99,254.00

Explanation: To be funded from the PEG Access and Cable Related Fund.

FINANCE COMMITTEE RECOMMENDS THIS ARTICLE BE ACCEPTED AND ADOPTED. VOTE: YES-#, NO-#

ROLL CALL VOTES:

Finance Committee:

To accept and adopt:

Yeas: # (number): [Members by Roll Call]

Nays: # (number): [Members by Roll Call]

Board of Selectmen:

To accept and adopt:

Yeas: # (number): [Members by Roll Call]

Land acquisitions for the protection of well head and water supply

Article 23: To see if the Town will vote to authorize the Water and Wastewater Commission to acquire by purchase, gift, eminent domain, or otherwise, five parcels of land, all with an address of 0 Chatham Road, identified as Assessor's Owners Unknown Parcels 43-E7-0, 43-E9-0, 43-E9-A-0, 43-E10-0, and 43-E12-0, consisting of 7.76 acres more or less, said parcels to be placed under the care, custody, control, and management of the Water and Wastewater Commission and held for well head and water supply protection purposes; and further to appropriate from Certified Retained Earnings of the Water Enterprise Fund the sum of \$175,000 more or less, for said acquisition, including all costs incidental and related thereto; provided however that said appropriation shall be reduced by the amount of any

gifts or grants received under the Cape Cod Commission DRI Grant program or any other grant program made available to the Town at the time of said acquisition;, and further to authorize the Water and Wastewater Commission to apply for any such grants and to enter into all necessary agreements and to take such actions as may be necessary to carry out the purposes of this Article; or to act in relation thereto. By request of the Water and Wastewater Commission. Estimated Cost: \$175,000.00.

Explanation: The Water Department is seeking funds to support the acquisition of 5 undeveloped parcels off Chatham Road totaling 7.76 acres abutting the Chatham Rd. wellfield. Acquisition of these parcels will further support the department's efforts to protect the water supply by limiting development immediately adjacent to the Chatham Road wellfield. The requested funds will be used to support the necessary title research and property acquisition. Funds used for the property acquisition are eligible for 100% reimbursement through Cape Cod Commission DRI funds.

FINANCE COMMITTEE RECOMMENDS THIS ARTICLE BE ACCEPTED AND ADOPTED. VOTE: YES-#, NO-#

ROLL CALL VOTES:

Finance Committee:

To accept and adopt:

Yeas: # (number): [Members by Roll Call]

Nays: # (number): [Members by Roll Call]

Board of Selectmen:

To accept and adopt:

Yeas: # (number): [Members by Roll Call]

New source exploration for town water supply

Article 24: To see if the Town if the Town will vote to appropriate from Certified Retained Earnings of the Water Enterprise Fund a sum of money to conduct new source exploration for the Town's water supply, including all costs incidental and related thereto; and to act fully thereon. By request of the Water and Wastewater Commission. Estimated Cost: \$250,000.00.

Explanation: The Water Department is seeking \$250,000 to conduct well exploration in North Harwich. Services rendered through this appropriation will include site review and mapping, installation of 2-inch & 4-inch test wells, well development and pump testing of 4-inch wells, and preparation of Mass DEP Request for Site Examination and Prolonged Test Pumping Proposal. Should a viable production well be identified a future appropriation will be required to install the final well casing and pump house.

FINANCE COMMITTEE RECOMMENDS THIS ARTICLE BE ACCEPTED AND ADOPTED. VOTE: YES-#, NO-#

ROLL CALL VOTES:

Finance Committee:

To accept and adopt:
Yeas: # (number): [Members by Roll Call]
Nays: # (number): [Members by Roll Call]

Board of Selectmen:

To accept and adopt:
Yeas: # (number): [Members by Roll Call]
Nays: # (number): [Members by Roll Call]

Route 28 Water Main Replacement Design

Article 25: To see if the Town if the Town will vote to appropriate from Certified Retained Earnings of the Water Enterprise Fund a sum of money for the design and engineering for the replacement of approximately 1.75 miles of water main replacement on Route 28 between Lower County Road and the Herring River Bridge, including all costs incidental and related thereto; and to act fully thereon. By request of the Water and Wastewater Commission. Estimated Cost: \$500,000.00.

Explanation: The Water Department is seeking \$500,000 for the purpose of preparing plans and specifications for the replacement of approximately 1.75 miles of water main on Route 28 from Lower County Road to the Herring River Bridge. The existing water was installed in the 1940's and is beyond its useful life and the subject of several water main breaks. This segment of water main also contains very few gate valves which requires as many as 25 valves to be closed to isolate and repair the water main after a break leaving larges sections of town without water during the repair. Should this article be approved a future appropriating will be required to complete the work.

FINANCE COMMITTEE RECOMMENDS THIS ARTICLE BE ACCEPTED AND ADOPTED. VOTE: YES-#, NO-#

ROLL CALL VOTES:

Finance Committee:

To accept and adopt:
Yeas: # (number): [Members by Roll Call]
Nays: # (number): [Members by Roll Call]

Board of Selectmen:

To accept and adopt:
Yeas: # (number): [Members by Roll Call]
Nays: # (number): [Members by Roll Call]

Station 8 Generator

Article 26: To see if the Town will vote to appropriate from Certified Retained Earnings of the Water Enterprise Fund a sum of money to purchase, equip, and install a new generator for Station 8, including all costs incidental and related thereto; and to act fully thereon. By request of the Water and Wastewater Commission. Estimated Cost: \$50,000.00.

Explanation: The Water Department is seeking funds to replace a 2005 Generac generator located at Station 8 which provides back-up power to Well #8 and the corrosion control facility on Bat Road. The generator has been in service for 16 years and can no longer be relied upon for back-up power.

FINANCE COMMITTEE RECOMMENDS THIS ARTICLE BE ACCEPTED AND ADOPTED. VOTE: YES-#, NO-#

ROLL CALL VOTES:

Finance Committee:

To accept and adopt:

Yeas: # (number): [Members by Roll Call]

Nays: # (number): [Members by Roll Call]

Board of Selectmen:

To accept and adopt:

Yeas: # (number): [Members by Roll Call]

Nays: # (number): [Members by Roll Call]

Appropriate Sums of Money from the FY 2022 Estimated Annual Revenues of the Community Preservation Act Fund

Article 27: To see if the Town will vote to appropriate the following sums of money from the FY 2022 estimated annual revenues of the Harwich Community Preservation Act Fund as required by the G.L. Chapter 44B and Chapter 149, §298 of the Acts of 2004 as follows:

- A sum of money for the acquisition, creation and preservation of the open space;
- A sum of money for the acquisition, preservation, restoration and rehabilitation of historic resources;
- A sum of money for the acquisition, creation, preservation and support of community housing; and
- A sum of money for the Community Preservation Act Fund FY2022 Undesignated Fund Balance (including Recreation)

and to act fully thereon. By request of the Community Preservation Committee.

<u>Appropriation</u>	<u>FY 2022</u>
Community Housing Reserve	\$154,126.00
Open Space Reserve	\$154,126.00

Historic Preservation Reserve	\$154,126.00
Undesignated Fund Balance Operating Expenses	\$25,000

Explanation:

FINANCE COMMITTEE RECOMMENDS THIS ARTICLE BE ACCEPTED AND ADOPTED. VOTE: YES-#, NO-#

ROLL CALL VOTES:

Finance Committee:

To accept and adopt:

Yeas: # (number): [Members by Roll Call]

Nays: # (number): [Members by Roll Call]

Board of Selectmen:

To accept and adopt:

Yeas: # (number): [Members by Roll Call]

Nays: # (number): [Members by Roll Call]

Fund Land Bank Debt Service

Article 28: To see if the Town will vote to appropriate from the Community Preservation Act Funds – \$51,692.06 from the Undesignated Fund Balance and \$181,357.94 from estimated annual revenue for Fiscal Year 2022 for a total of \$233,050 to fund the Land Bank Debt Service. Any funds left unspent from this Article are to be returned to the Community Preservation Act Funds – Undesignated Fund Balance, and to act fully thereon. By request of the Community Preservation Committee and the Finance Director. Estimated Cost: \$223,050.

FINANCE COMMITTEE RECOMMENDS THIS ARTICLE BE ACCEPTED AND ADOPTED. VOTE: YES-#, NO-#

ROLL CALL VOTES:

Finance Committee:

To accept and adopt:

Yeas: # (number): [Members by Roll Call]

Nays: # (number): [Members by Roll Call]

Board of Selectmen:

To accept and adopt:

Yeas: # (number): [Members by Roll Call]

Nays: # (number): [Members by Roll Call]

Community Preservation Activities under \$50,000

Article 29: To see if the Town will vote to appropriate from the Community Preservation Act Funds a sufficient sum of money to fund the items in the table below consistent with their respective applications, with each item considered a separate appropriation. Any funds left unspent from this Article are to be returned to the Community Preservation Act Fund from which the appropriation is made as specified in the chart below, and further authorize the Board of Selectmen to enter into grant agreements with the Cape & Islands Veterans Outreach Center and Community Development Partnership, and to act fully thereon. By request of the Community Preservation Committee. Estimated Cost: \$127,066

Item #	Project	Purpose	Amount	Appropriation Source
1	Old Colony Rail Trail Harwich/Chatham Town Border marker project	To delineate town boundaries along the Old Colony Rail Trail	\$1,000.00	Estimated annual revenue for FY 2022
	Lower Cape Housing Institute	Ongoing support of the Cape Housing Institute	\$7,500.00	Community Housing Reserve
2	Crossing lights at Depot Road South	Ongoing effort to enhance safety through the Rail Trails	\$15,000.00	Estimated annual revenue for FY 2022
3	Veterans Home – Dennis, MA	Support the Cape & Islands Veterans Outreach Center's effort to creating housing; and to authorize the Board of Selectmen to enter into a grant agreement between the Town of Harwich and the Veteran's Outreach Center.	\$15,000.00	Estimated annual revenue for FY 2022
4	Senior Memorial Field fencing project	Install new fencing at widely used softball field	\$40,181.00	Estimated annual revenue for FY 2022

5	Phase I of II for Veterans Memorial Circle at Evergreen Cemetery	Install flags, lighting and related electrical service	\$48,385.00	Estimated annual revenue for FY 2022
		Total:	\$127,066.00	

East Harwich Methodist Church Cemetery Gravestone Project

Article 30: To see if the Town will vote to appropriate from Community Preservation Act Funds- estimated annual revenue for Fiscal Year 2022 \$112,200 to support the East Harwich Methodist Church Cemetery Gravestone Project. Any funds left unspent from this Article are to be returned to the Community Preservation Act Funds - Undesignated Fund Balance, and to act fully thereon. By request of the Community Preservation Committee and the Cemetery Commission. Estimated Cost: \$112,200.00.

Explanation: The article funds the cleaning, consolidation, repair and/or resetting of grave markers in the East Harwich Methodist Church Cemetery.

FINANCE COMMITTEE RECOMMENDS THIS ARTICLE BE ACCEPTED AND ADOPTED. VOTE: YES-#, NO-#

ROLL CALL VOTES:

Finance Committee:

To accept and adopt:

Yeas: # (number): [Members by Roll Call]

Nays: # (number): [Members by Roll Call]

Board of Selectmen:

To accept and adopt:

Yeas: # (number): [Members by Roll Call]

Nays: # (number): [Members by Roll Call]

Brooks Academy Structural Improvement Projects

Article 31: To see if the Town will vote to appropriate from Community Preservation Act Funds - \$485,734.55 from the Historic Reserve, \$664,265.45 from the estimated annual revenue for Fiscal Year 2022, for a total appropriation of \$1,150,000.000, to make structural improvements to Brooks Academy. Any funds left unspent from this Article are to be returned to the Community Preservation Act Funds-Historic Reserve and to act fully thereon. By request of the Community Preservation Committee and the Brooks Academy Museum Commission. Estimated Cost: \$1,150,000.00.

Explanation:

FINANCE COMMITTEE RECOMMENDS THIS ARTICLE BE ACCEPTED AND ADOPTED. VOTE: YES-#, NO-#

ROLL CALL VOTES:

Finance Committee:

To accept and adopt:

Yeas: # (number): [Members by Roll Call]

Nays: # (number): [Members by Roll Call]

Board of Selectmen:

To accept and adopt:

Yeas: # (number): [Members by Roll Call]

Nays: # (number): [Members by Roll Call]

Fund a Part-Time Housing Coordinator

Article 32: To see if the Town will vote to appropriate from Community Preservation Act Funds- \$50,000.00 from the estimated annual revenue for Fiscal Year 2022 to fund the Harwich Affordable Housing Trust Housing Coordinator. Any funds left unspent from this Article are to be returned to the Community Preservation Act Funds-Housing Reserve, and to act fully thereon. By request of the Community Preservation Committee and the Affordable Housing Trust. Estimated Cost: \$50,000.00.

Explanation: Annual request to fund a part-time housing coordinator to support the Affordable Housing Trust.

FINANCE COMMITTEE RECOMMENDS THIS ARTICLE BE ACCEPTED AND ADOPTED. VOTE: YES-#, NO-#

ROLL CALL VOTES:

Finance Committee:

To accept and adopt:

Yeas: # (number): [Members by Roll Call]

Nays: # (number): [Members by Roll Call]

Board of Selectmen:

To accept and adopt:

Yeas: # (number): [Members by Roll Call]

Nays: # (number): [Members by Roll Call]

Hinckleys Pond Watershed Preservation Project

Article 33: To see if the Town will vote to appropriate from Community Preservation Act Funds - \$360,000.00 from the Open Space Reserve to fund the acquisition of a parcel of land located on Headwaters Drive and identified as Assessor's Parcel 81-G1, and costs incidental or related thereto, and to authorize the Board of Selectmen to acquire said parcel

for open space and passive recreation purposes by purchase, gift, and/or eminent domain on such terms and conditions as the Board of Selectmen deems in the best interests of the Town, and to grant a conservation restriction thereon to Harwich Conservation Trust and/or any other qualified entity pursuant to G.L. c. 184, §§31-33 and meeting the requirements of G.L. c. 44B, §12(a), with the care, custody and control of said parcel to be held by the Conservation Commission pursuant to the provisions of G.L. c. 40, §8C, Any funds left unspent from this Article are to be returned to the Community Preservation Act Funds-Open Space Reserve, and to act fully thereon. By request of the Community Preservation Committee and the Real Estate & Open Space Committee. Estimated Cost: \$360,000.00.

Explanation: The goal of this article is to support a partnership between the Town, State, and nonprofit Harwich Conservation Trust (HCT) that will result in the preservation of approximately 31 acres in the Hinckleys Pond/Herring River Watershed to protect water quality, walking trails, land bordering the Cape Cod Rail Trail bike path, scenic views, and wildlife habitat. The following parcels owned by the Jenkins Nominee Trust (9 deeds) would be purchased by the Town, the Commonwealth of Massachusetts, and the Harwich Conservation Trust: Assessor Map 81, Lot G1: Assessor Map 81, Lot G2-1: Assessor Map 81, Lot G2-2: Assessor Map 81, Lot G2-3: Assessor Map 81, Lot G2-4-1: Assessor Map 81, Lot G2-4-2: Assessor Map 81, Lot G3: Assessor Map 81, Lot G3-1

FINANCE COMMITTEE RECOMMENDS THIS ARTICLE BE ACCEPTED AND ADOPTED. VOTE: YES-#, NO-#

ROLL CALL VOTES:

Finance Committee:

To accept and adopt:

Yeas: # (number): [Members by Roll Call]

Nays: # (number): [Members by Roll Call]

Board of Selectmen:

To accept and adopt:

Yeas: # (number): [Members by Roll Call]

Nays: # (number): [Members by Roll Call]

Harwich Natural Heritage Trail Project

Article 34: To see if the Town will vote to appropriate from Community Preservation Act Funds - \$150,000 from estimated annual revenue for Fiscal Year 2022 to fund the Natural Heritage Trail Project, including the creation of a wheelchair accessible trail loop off Bank Street for open space and recreational purposes, and further to authorize the Board of Selectmen to enter into a grant agreement with the Harwich Conservation Trust, and further to authorize the Board of Selectmen to acquire a permanent restriction on said land. Any funds left unspent from this Article are to be returned to the Community Preservation Act Funds-Undesignated Fund Balance, and to act fully thereon. By request of the Community Preservation Committee. Estimated Cost: \$150,000.00.

Explanation: The Harwich Natural Heritage Trail Project goal is to enhance the recreational and educational experience in Harwich by creating a wheelchair accessible trail loop off Bank Street at HCT's Robert F. Smith Cold Brook Preserve, which is also the site of a HCT/Town ecological restoration partnership. Harwich residents and visitors will be able to enjoy passive recreational opportunities (walking, birdwatching, dog walking, photography, and more) in a scenic and ecologically restored destination between Harwich Center and downtown Harwich Port.

FINANCE COMMITTEE RECOMMENDS THIS ARTICLE BE ACCEPTED AND ADOPTED. VOTE: YES-#, NO-#

ROLL CALL VOTES:

Finance Committee:

To accept and adopt:

Yeas: # (number): [Members by Roll Call]

Nays: # (number): [Members by Roll Call]

Board of Selectmen:

To accept and adopt:

Yeas: # (number): [Members by Roll Call]

Nays: # (number): [Members by Roll Call]

Brooks Park Lighting Project

Article 35: To see if the Town will vote to appropriate from Community Preservation Act Funds - \$125,000 from estimated annual revenue for Fiscal Year 2022 to fund the Brooks Park Lighting Project. Any funds left unspent from this Article are to be returned to the Community Preservation Act Funds-Undesignated Fund Balance, and to act fully thereon. By request of the Community Preservation Committee and the Recreation & Youth Commission. Estimated Cost: \$125,000.00.

Explanation:

FINANCE COMMITTEE RECOMMENDS THIS ARTICLE BE ACCEPTED AND ADOPTED. VOTE: YES-#, NO-#

ROLL CALL VOTES:

Finance Committee:

To accept and adopt:

Yeas: # (number): [Members by Roll Call]

Nays: # (number): [Members by Roll Call]

Board of Selectmen:

To accept and adopt:

Yeas: # (number): [Members by Roll Call]

Nays: # (number): [Members by Roll Call]

Sand Pond Revitalization Project

Article 36: To see if the Town will vote to appropriate from Community Preservation Act Funds - \$83,500.00 from estimated annual revenue for Fiscal Year 2022 to fund the rehabilitation and restoration of Sand Pond, which is a recreational facility owned by the Town of Harwich. Any funds left unspent from this Article are to be returned to the Community Preservation Act Funds-Undesignated Fund Balance, and to act fully thereon. By request of the Community Preservation Committee and the Recreation & Youth Commission. Estimated Cost: \$83,500.00.

Explanation:

FINANCE COMMITTEE RECOMMENDS THIS ARTICLE BE ACCEPTED AND ADOPTED. VOTE: YES-#, NO-#

ROLL CALL VOTES:

Finance Committee:

To accept and adopt:

Yeas: # (number): [Members by Roll Call]

Nays: # (number): [Members by Roll Call]

Board of Selectmen:

To accept and adopt:

Yeas: # (number): [Members by Roll Call]

Nays: # (number): [Members by Roll Call]

Amend The Code of The Town Of Harwich Charter to Amend Chapter 9, Section 6

Article 37: To see if the Town will vote pursuant to M.G.L. c.43B, §10 to amend Chapter 9, Section 6 of the Town Charter, as set forth below, with strikethrough text to be deleted and bold, underlined text to be inserted:

Section 6. Capital Outlay Plan

9-6-1 The purpose of the ~~7~~ **5**-year capital outlay plan shall be to provide the town with a long-range forecast of the town's major capital improvement needs and to attempt to keep debt borrowing levels as even as possible from year to year.

9-6-2 A "capital outlay" shall mean the acquisition, construction or renovation of buildings, equipment or land having a total cost of \$50,000 **or more** during any budget year and planning funds for any such capital outlay.

9-6-3 The town administrator and the capital outlay committee shall submit a ~~7~~ **5**-year capital outlay plan to a joint public meeting of the board of selectmen and the finance committee during the month of December of each year.

9-6-4 The board of selectmen shall prepare articles to be included in the May annual town meeting warrant seeking adoption of the ~~7~~ 5-year capital outlay plan and funding of the current year of the plan.

9-6-5 A simple majority vote of the town meeting shall be required to adopt the ~~7~~ 5-year capital outlay plan as submitted. Any amendment to a previously adopted Capital Plan shall require a two-thirds vote at the Annual Town Meeting.

9-6-6 If any part of the current year of the plan receives funding support at the annual town meeting, but fails at any necessary debt exclusion, capital exclusion or proposition 2 1/2 override ballot votes, the unsupported portion shall be returned to the ~~7~~ 5-year capital plan in year 1 of the next ~~7~~ 5-year plan, and to act fully thereon. By the Board of Selectmen.

Explanation: This article seeks to correct defects in Article 36 at the Annual Town Meeting in 2019. The statement under the Finance Committee's recommendation at that time indicated that the article was intended to modify the Capital Outlay Plan from seven (7) years to five (5) years. The article amends 9-6-2 by providing text to qualify that capital outlay items are \$50,000 or greater. These amendments will be subject to approval by the voters at the 2022 Annual Town Election if adopted at this town meeting.

FINANCE COMMITTEE RECOMMENDS THIS ARTICLE BE ACCEPTED AND ADOPTED. VOTE: YES-#, NO-#

ROLL CALL VOTES:

Finance Committee:

To accept and adopt:

Yeas: # (number): [Members by Roll Call]

Nays: # (number): [Members by Roll Call]

Board of Selectmen:

To accept and adopt:

Yeas: # (number): [Members by Roll Call]

Nays: # (number): [Members by Roll Call]

Amend Zoning Bylaw - §325-42 Design Requirements, Subsection L

Article 38: To see if the Town will vote to amend the Code of the Town of Harwich – Zoning Bylaw by amending §325-42.L by making the following changes (new text shown in **bold underline** and deleted language shown in strike-out):

Parking and loading zone setbacks for all uses except single-family, two-family and single-family with accessory apartment shall be as follows. For commercial structures, wheel stops for parking spaces perpendicular to or at an angle to a structure shall be located so as to provide a clear area of three feet between the end of a vehicle parked in the space and the nearest structure.

**Parking Setbacks¹
(feet)**

Zone	Street	Side Line	Rear
RR, RM, RL, RH-1, RH-2 and RH-3	20	10	10
CV, CH-1 and CH-2	20	10	10
IL	15	5	5
MRL and MRL-1	50	50	50
	<u>Note 2</u>	<u>Note 2</u>	<u>Note 2</u>

Notes:

¹ No parking area containing more than four spaces or loading area shall be located within a required front yard, except that those buildings utilizing the provisions of §325-51L (Village Commercial Overlay District) shall not locate any parking within the front yard.

²(a) On properties with existing structures, the setbacks for parking shall be established at the time of the site plan review.

(b) For vacant lands to be developed for any purpose (other than single-family, two-family and single-family with accessory apartment) the minimum setbacks for parking shall be 25 feet from the street and rear property line and 20 feet from the side property line.

And to act fully thereon. By request of the Planning Board

Explanation: These changes would allow for creativity and flexibility for parking within the MRL and MRL-1 zoning district, particularly for already improved properties.

FINANCE COMMITTEE RECOMMENDS THIS ARTICLE BE ACCEPTED AND ADOPTED. VOTE: YES-#, NO-#

ROLL CALL VOTES:

Finance Committee:

To accept and adopt:

Yeas: # (number): [Members by Roll Call]

Nays: # (number): [Members by Roll Call]

Board of Selectmen:

To accept and adopt:

Yeas: # (number): [Members by Roll Call]

Nays: # (number): [Members by Roll Call]

Amend Zoning Article XXIV By Adding A New Section - §325-160 Design Guidelines

Article 39: To see if the Town will vote to amend the Code of the Town of Harwich – Zoning Article XXIV West Harwich Special District by adding a new §325-160 as follows:

§325-160 Design Guidelines

For the purpose of this section the Harwich Planning Board, after a public hearing, shall adopt “*West Harwich Special District Site and Architectural Design Guidelines*” which shall constitute rules and regulations guiding historic structures and new construction within the WHSD. And to act fully thereon. By request of the Planning Board

***Explanation:** The new section 325-160 references design guidelines for the West Harwich Special District, which will be created and adopted by the Harwich Planning Board through a separate public hearing process. These guidelines will assist property owners and applicants with the development and redevelopment of properties within the West Harwich Special District (aka the West Harwich DCPC).*

FINANCE COMMITTEE RECOMMENDS THIS ARTICLE BE ACCEPTED AND ADOPTED. VOTE: YES-#, NO-#

ROLL CALL VOTES:

Finance Committee:

To accept and adopt:

Yeas: # (number): [Members by Roll Call]

Nays: # (number): [Members by Roll Call]

Board of Selectmen:

To accept and adopt:

Yeas: # (number): [Members by Roll Call]

Nays: # (number): [Members by Roll Call]

Amend General Bylaw Ch. 304 – Water Dependent Structures

Article 40: To see if the Town will vote to amend the Code of the Town of Harwich under the General Bylaw Chapter 304 Water Dependent Structures as follows (new text shown in **bold underline** and deleted language shown in strike-out):

Within §304-1. Purpose - add the phrase “**elevated walkway**” after “dock” in the first sentence.

Within §304-2 Definitions – add one new definition as follows:

CUMULATIVE IMPACT - The effect of a subject activity which, when considered in isolation, may or may not have a significant impact on environmental interests but when considered in relation to other past, present or anticipated future activities in a given area can be expected to be significant in the aggregate.

And further, amend the definitions of Mean High Water, Piling, and Water Dependent Structure as follows:

MEAN HIGH WATER - The elevation in feet above **North American Vertical Datum of 1988 (NAVD 88)** National Geodetic Vertical Datum (NGVD) established by the present arithmetic mean of the water heights observed at high tide over a specific nineteen-year Metonic cycle (the National Tidal Datum Epoch) as shown on the New England Coastline Tidal Flood Survey - Tidal Flood Profile No. 9 Barnstable to Chatham, MA by the New England Division, Corps of Engineers. Where salt marsh occurs, the mean high tide will be that point where *Spartina alterniflora* gives way to *Spartina patens*. Walkways over salt marshes that extend beyond this intersection will be regulated under the provisions of this bylaw.

PILING - A column constructed from any material used to support the deck or other structural member of a wharf, pier, **elevated walkway**, or dock or to serve as a mooring spar or dolphin for vessels or floats.

WATER-DEPENDENT STRUCTURE - Any structure or combination of structures built adjacent to or at an angle from the shore and extending seaward beyond the mean high-water mark so that **people may access the water** ~~vessels may lie alongside to receive and discharge passengers or cargo or for use as a promenade~~ and shall include structures commonly referred to as floats, docks, piers, **elevated walkways**, or wharves.

Within §304-4 Restricted Areas –amend as follows (new language is shown in **bold underline** and deleted text is shown in ~~strike-out~~):

No permit shall be issued for construction of a new, private, water-dependent structure in the **following areas**: of

Round Cove of **in** Pleasant Bay. This area includes all contiguous parcels beginning with the northerly boundary of the property (Map and Parcel Number 115-S1-3) and extending southerly along the shore to the southerly boundary of the property (Map and Parcel Number 109-B1-5), and all shore front parcels between these two properties, including Round Cove. This prohibition does not apply to existing, licensed structures or to the maintenance of existing, licensed structures.

Both sides of the Herring River. This area includes all contiguous parcels beginning at the northerly boundary of Map 28 Parcel D1 on North Road near the pedestrian bridge over the river, and extending southerly down the river to the southern boundary of 1 Belmont Road, Map 1 Parcel C1, at the mouth of the river where it opens up to Nantucket Sound.

Within § 304-5 Application for a permit in section B1, change fourteen copies to twelve, and add the phrase “and narratives’ after “plans” in the first sentence.

Within § 304-8 Standards to be met, amend sections D, F, H, and J, and add a section K as follows (new language is shown in **bold underline** and deleted text is shown in ~~strike-out~~).

D. No structure (except floats) shall exceed four feet of ~~walkway~~ **in** width. **The width may be waived for public structures in compliance with 521 CMR (Massachusetts Architectural Access Board Regulations).**

F. In order to protect the foreshore, all structures (except floats) shall be supported by pilings. Decks shall have a minimum $1\frac{1}{2}$ $\frac{3}{4}$ inch spacing between deck planks, **or may use grating instead with permission from the Commission**, and shall be at an elevation **height** equal to **1.5 times** the width of the deck above mean high water or, in areas of marsh, above the marsh vegetation **the salt marsh to the decking**, whichever is higher. **In areas where the structure is over a wetland resource area other than salt marsh, the height may be equal to 1.25 times the width of the deck**. Notwithstanding the foregoing, in all areas where the foreshore is passable on foot, a flight of stairs on either side of the deck shall be provided to allow persons to lawfully use the foreshore, **or be of a height that persons may pass underneath with**. A directional sign in compliance with the Zoning Bylaw, Chapter 325, Article VII, shall be placed indicating permission to cross the structure.

H. No structure shall be located within 50 feet of an existing eelgrass bed or within a shellfish area defined by the Town bylaws or Town Shellfish Warden, **unless expressly allowed by a variance from the Conservation Commission upon clear and convincing evidence provided by the applicant that the proposed project will not have an adverse impact to the wetland resource area(s) or its interest(s)**. **An indication** of the presence or absence of shellfish at a proposed site ~~must~~ **may** be determined by a shellfish survey submitted by the applicant. **This shellfish survey shall conform to the sampling methods set forth in the Harwich Wetland Protection Regulations**. The survey shall include existing populations of all sizes of commercially important species of shellfish (clams, **oysters**, quahogs, scallops, and mussels) and shall also include other species of mollusks which may indicate the capacity of the area to support commercially important species. The survey shall also include a description of shell fragments, if feasible, and references, if available, to historical information regarding the presence or absence of shellfish species. Within the Pleasant Bay ACEC, relocation of shellfish encountered during construction of a project is not acceptable mitigation (except when the project is part of a Town- or state-sponsored shellfish relay program, and then only if it can be clearly shown that the productivity of that shellfish bed would not be diminished by its relocation).

~~J. In order to provide the underlying seabed full exposure to sunlight during six months of the year, all proposed structures shall be seasonal, with seven months' maximum use. Off-season storage plans shall be submitted for review and approval by the Conservation Commission.~~

J. Recreational water dependent structures are allowed to be used for six months out of the year (May-October). Floats are to be removed from the water by November 1 annually. Off-season storage of the floats shall be off site or outside of the 50' wetland buffer and not on any native plant species. Storage of the float on the marsh is strictly prohibited, and shall result in enforcement action from the commission.

K. There shall be a depth of at least three feet at mean low water on all sides of the float. No vessel shall be aground at mean low water.

Within §304-9 Denial of a Permit – amend as follows (new language is shown in **bold underline** and deleted text is shown in ~~strike out~~):

The Commission may deny a permit in any case where a proposed **water dependent** structure or combination of structures, **does not meet the criteria set forth in this Bylaw.** ~~otherwise complying herewith, would not extend to a point where at mean low water a water depth of at least 2 1/2 feet is maintained no vessel shall be aground at mean low water.~~

And to act fully thereon. By request of the Conservation Commission

FINANCE COMMITTEE RECOMMENDS THIS ARTICLE BE ACCEPTED AND ADOPTED. VOTE: YES-#, NO-#

ROLL CALL VOTES:

Finance Committee:

To accept and adopt:

Yeas: # (number): [Members by Roll Call]

Nays: # (number): [Members by Roll Call]

Board of Selectmen:

To accept and adopt:

Yeas: # (number): [Members by Roll Call]

Nays: # (number): [Members by Roll Call]

Amend General Bylaw Ch. 310 – Wetlands Protection Bylaw

Article 41: To see if the Town will vote to amend the Code of the Town of Harwich under the General Bylaw Chapter 310 Wetlands Protection as follows:

Within §310-2. Definitions, Paragraph A, delete the last sentence under the definition of Agriculture and the definition of Aquaculture,

and further, add seven new definitions, in alphabetical order as follows:

BUFFER ZONE - The jurisdictional area extending 100 feet landward from a wetland resource area as defined in §310-3 herein. Land Subject to Coastal Storm Flowage and Riverfront Area do not have any buffer zones under this bylaw.

CUMULATIVE IMPACT - The effect of a subject activity which, when considered in isolation, may or may not have a significant impact on environmental interests but when considered in relation to other past, present or anticipated future activities in a given area can be expected to be significant in the aggregate.

MITIGATION - The means to offset any potential negative impacts a project may have on a wetland resource area(s) or buffer zone(s) thereto, and a means to improve the wetland resource area(s) and their interests on the site. There are various forms of mitigation the Commission may consider, including but not limited to on-site mitigation, off-site mitigation, and in-lieu fees on mitigation-constrained sites to improve specific other wetland resource areas in town.

MITIGATION-CONSTRAINED SITES - A project site that does not lend itself to the need for any on-site mitigation, but due to the proposed activity on the site, requires mitigation as per the Harwich Wetlands Protection Regulations.

SIXTY FOOT NO NEW STRUCTURE ZONE - The 60 foot no new structure zone is the upland area that extends from the landward edge of the wetland sixty feet inland as determined by a professional land survey and approved wetland delineation. When siting a new building or an addition within the 50-100-foot buffer zone, the structure shall be set back at least 60 feet from the resource area to allow for human and wildlife passage between the building and the 50-foot buffer, to reduce alteration to the 50-foot buffer, and to avoid the intrusion of lawn in the 50-foot buffer. Within the 50-60' buffer area, no new structure is permitted that would impede access so as to cause intrusion into the 50' No Disturb Zone.

SHELLFISH - Mollusks including by not limited to the following: clams, conchs, mussels, oysters, periwinkles, quahogs, razor clams, scallops, and sea clams; and crustaceans such as lobster or crab.

VARIANCE - An official dispensation from a rule or regulation. As it pertains to the Harwich Wetlands Bylaw and Regulations, a variance will only be allowed upon

clear and convincing evidence by the applicant that a proposed activity will not have an adverse impact on any wetland resource area, buffer zone, or their interests.

and further, amend the definition of No-Disturb Zone as follows (new language is shown in **bold underline** and deleted text is shown in ~~strike-out~~):

NO-DISTURB ZONE - The land running 50 feet landward from **the landward limit of** an abutting **wetland** resource area as determined by a professional land survey **and approved wetland delineation**. No ~~substantial~~ activity, that will result in the building within or upon, filling, removing or altering of land, shall be permitted, with the following exceptions:

- (1) Maintenance **or reconstruction** of an existing permitted structure **within the same footprint**.
- (2) An activity that has been expressly allowed by a variance from the Conservation Commission.

Amend §310-3. Jurisdiction, paragraph A as follows (new language is shown in **bold underline** and deleted text is shown in ~~strike-out~~):

Freshwater wetland resource areas. Marshes; wet meadows; bogs; swamps; vernal pools and vernal pool habitat; lands subject to flooding, both bordering and isolated; isolated wetlands greater than 3,000 square feet; banks; reservoirs; lakes; ponds greater than ~~3,000~~ **1,000** square feet; rivers, including the two-hundred-foot riverfront area; streams and creeks, including intermittent streams; and the lands underneath lakes, ponds, streams and creeks.

and further amend paragraph C as follows (new language is shown in bold underline)

Lands within 100 feet of any of the aforesaid resource areas, as set out in this section, except for the riverfront area, **land subject to coastal storm flowage** and **the landward limit of** vernal pool habitat.

And further, insert a new paragraph D as follows:

D. Conservation variance provision. In rare and unusual circumstances the Commission, at its sole discretion, may grant a conservation variance from the requirements of this bylaw. Such a conservation variance shall be granted only in the following cases:

- (1) Where maximum feasible compliance is achieved; and
- (2) Where there are clear and compelling reasons of public safety and welfare;
or
- (3) Where the proposed project will enhance the environmental values protected by the bylaw; or

- (4) **Upon a clear and convincing showing of evidence by the applicant that the proposed work will not adversely affect the environmental values protected by the bylaw.**

Amend §310-4 Conditional Exceptions, paragraph B, as follows (new language is shown in bold): :

The provisions of this bylaw shall not apply to any mosquito control work done under the provisions of MGL c. 252 or any special act, to maintenance of drainage and flooding systems of **active, lawful** cranberry bogs and to work performed for normal maintenance or improvement of land in agricultural use or in aquacultural use, or to any project authorized by special act prior to January 1, 1973.

And further, in paragraph C change allow 30 days instead of 21 days after the commencement of an emergency project for a permit application to be filed with the Conservation Commission;

And further, amend paragraph D, as follows (new language is shown in bold underline and deleted text is shown in strike-out):

Conservation variance provision. In rare and unusual circumstances the Commission, at its discretion, may grant a conservation variance from the requirements of **this Bylaw and associated Wetland Protection Regulations** ~~the fifty-foot no-disturb zone~~. Such a conservation variance may be granted upon a clear and convincing showing of evidence by the applicant that the proposed work will not adversely affect the environmental values protected by this bylaw.

Within §310-8 Permits and conditions, paragraph C, insert the word “provide” after the word “shall in the second sentence.

and further, add the following new paragraphs:

J. Pursuant to G.L. c. 44, § 53G, the Commission is authorized to require an applicant to pay a fee for the reasonable costs and expenses borne by the Commission for specific expert engineering and other consultant services deemed necessary by the Commission to come to a final decision on the application. This fee is called the consultant fee. The specific consultant services may include but are not limited to the resource area survey and delineation, analysis of resource area values, including wildlife habitat evaluations, hydrogeologic and drainage analysis and environmental or land use law.

K. The Commission may require the payment of the consultant fee at any point in its deliberations prior to a final decision. The applicant shall pay the fee to the Town to be put into a consultant services account of the Commission which may be drawn upon by the Commission for specific consultant services approved by the Commission at one of its public meetings.

L. The exercise of discretion by the Commission in making its determination to require the payment of a fee shall be based upon its reasonable finding that additional information acquirable only through outside consultants would be necessary for the making of an objective decision.

M. The Commission shall return any unused portion of the consultant fee to the applicant unless the Commission decides at a public meeting that other action is necessary. Any applicant aggrieved may appeal according to the provisions of the Massachusetts General Laws.

And to act fully thereon. By request of the Conservation Commission

FINANCE COMMITTEE RECOMMENDS THIS ARTICLE BE ACCEPTED AND ADOPTED. VOTE: YES-#, NO-#

ROLL CALL VOTES:

Finance Committee:

To accept and adopt:

Yeas: # (number): [Members by Roll Call]

Nays: # (number): [Members by Roll Call]

Board of Selectmen:

To accept and adopt:

Yeas: # (number): [Members by Roll Call]

Nays: # (number): [Members by Roll Call]

Amend General Bylaw Ch. 131 – Historic Preservation

Article 42: To see if the Town will vote to **[PLACEHOLDER FOR HDHC Demolition Delay Bylaw]**

Explanation: Provides consistency of Demolition Delay document across Cape towns. Most towns use this format as base document. Value to town citizens but also to prospective purchasers, realtors, lawyers and builders a working across town boundaries.

FINANCE COMMITTEE RECOMMENDS THIS ARTICLE BE ACCEPTED AND ADOPTED. VOTE: YES-#, NO-#

ROLL CALL VOTES:

Finance Committee:

To accept and adopt:

Yeas: # (number): [Members by Roll Call]

Nays: # (number): [Members by Roll Call]

Board of Selectmen:

To accept and adopt:

Yeas: # (number): [Members by Roll Call]

Nays: # (number): [Members by Roll Call]

Approval of DHY Clean Waters Community Partnership Agreement

Article 43: To see if the Town will vote pursuant to Chapter 88 of the Acts of 2019 to approve an Agreement among the Towns of Dennis, Harwich, and Yarmouth for the establishment of a three town wastewater district to be known as the DHY Clean Waters Community Partnership, a copy of said agreement is on file in the office of the Town Clerk; it being understood that by approving said agreement the Town will be responsible for its apportioned share of the costs for permitting, design, and construction of a wastewater treatment facility, effluent recharge facilities and related infrastructure as well as the Town's apportioned share of the annual operation and maintenance cost of said facilities, or to act fully thereon. By request of the Board of Selectmen.

Explanation: [PLACEHOLDER ARTICLE PENDING FURTHER DISCUSSION BY BOS]

FINANCE COMMITTEE RECOMMENDS THIS ARTICLE BE ACCEPTED AND ADOPTED. VOTE: YES-#, NO-#

ROLL CALL VOTES:

Finance Committee:

To accept and adopt:

Yeas: # (number): [Members by Roll Call]

Nays: # (number): [Members by Roll Call]

Board of Selectmen:

To accept and adopt:

Yeas: # (number): [Members by Roll Call]

Nays: # (number): [Members by Roll Call]

Authorize the sale of 5 Bells Neck Road

Article 44: To see if the Town will vote to transfer the care, custody, management and control of the Town-owned property with the building thereon located at 5 Bells Neck Road from the Board of Selectmen for the purpose of leasing to a nonprofit for affordable and market-rate housing and for arts, cultural, educational or other purposes to the Board of Selectmen for the purpose of conveyance, and to authorize the Board of Selectmen to convey said property on such terms and conditions and for such consideration and purposes as the Board deems in the best interest of the Town, which may include reserving or obtaining a historic preservation restriction on said property, and to hereby rescind the terms, conditions and restrictions placed on the disposition of said property by the votes taken under Article 60 of the 2006 Annual Town Meeting and Article 12 of the Special Town Meeting of May, or to act fully thereon. By request of the Board of Selectmen.

Explanation: Previous efforts to lease this property were not successful. This article would allow the Board of Selectmen to seek Requests for Proposals (RFP) for the outright sale of this property in light of recent interest from several local groups to acquire the property.

Requires a two-thirds vote for adoption

FINANCE COMMITTEE RECOMMENDS THIS ARTICLE BE ACCEPTED AND ADOPTED. VOTE: YES-#, NO-#

ROLL CALL VOTES:

Finance Committee:

To accept and adopt:

Yeas: # (number): [Members by Roll Call]

Nays: # (number): [Members by Roll Call]

Board of Selectmen:

To accept and adopt:

Yeas: # (number): [Members by Roll Call]

Nays: # (number): [Members by Roll Call]

Amend the Code of Harwich General Bylaws – Chapter 8 Departmental Revolving Funds
§ 8-1. Funds Established

Article 45: To see if the Town will vote to amend the Departmental Revolving Funds Bylaw, Section 8-1 of the Town Code, (the language to be added is shown in underlined text), or to act fully thereon. By request of the Conservation Commission.

Revolving Fund	Authorize to Spend Fund	Revenue Source	Use of Fund
Wetlands	Conservation Commission	Notice of Intent Filing Fees; <u>as well as in-lieu fees generated as a result of an approval of a Notice of Intent</u>	Consultants and wetland and buffer zone management and restoration projects

FINANCE COMMITTEE RECOMMENDS THIS ARTICLE BE ACCEPTED AND ADOPTED. VOTE: YES-#, NO-#

ROLL CALL VOTES:

Finance Committee:

To accept and adopt:

Yeas: # (number): [Members by Roll Call]

Nays: # (number): [Members by Roll Call]

Board of Selectmen:

To accept and adopt:

Yeas: # (number): [Members by Roll Call]

Nays: # (number): [Members by Roll Call]

Annual Departmental Revolving Funds Authorization

Article 46: To see if the Town will vote to set spending limits for various revolving funds that have been authorized pursuant to Section 8.1 of the Town Code: and to act fully thereon. By request of the Finance Director.

<u>Revolving Fund</u>	<u>FY 2022 Spending Limit</u>	<u>Disposition of FY21 Fund balance</u>
Golf Pro Shop and Restaurant Lease Revenue	\$250,000	Available for expenditure
Golf Infrastructure fund	\$140,000	Available for expenditure
Council on Aging	\$125,000	Available for expenditure
Cemetery	\$100,000	Available for expenditure
Community Center	\$100,000	Available for expenditure
Recreation	\$175,000	Available for expenditure
Albro House	\$10,000	Available for expenditure
ADA	\$2,500	Available for expenditure
Wetlands	\$6,000	Available for expenditure
Middle School Cultural Center	\$225,000	Available for expenditure
Sidewalks	\$50,000	Available for expenditure
Tax Title Collection	\$36,000	Available for expenditure

FINANCE COMMITTEE RECOMMENDS THIS ARTICLE BE ACCEPTED AND ADOPTED. VOTE: YES-#, NO-#

ROLL CALL VOTES:

Finance Committee:

To accept and adopt:

Yeas: # (number): [Members by Roll Call]

Nays: # (number): [Members by Roll Call]

Board of Selectmen:

To accept and adopt:

Yeas: # (number): [Members by Roll Call]

Nays: # (number): [Members by Roll Call]

Stabilization Fund

Article 47: To see if the Town will vote to raise and appropriate or transfer from available funds a sufficient sum of money to be added to the Stabilization Fund, and to act fully thereon. By the request of the Board of Selectmen. Estimated cost: \$###,###.

FINANCE COMMITTEE RECOMMENDS THIS ARTICLE BE ACCEPTED AND ADOPTED. VOTE: YES-#, NO-#

ROLL CALL VOTES:

Finance Committee:

To accept and adopt:

Yeas: # (number): [Members by Roll Call]

Nays: # (number): [Members by Roll Call]

Board of Selectmen:

To accept and adopt:

Yeas: # (number): [Members by Roll Call]

Nays: # (number): [Members by Roll Call]

OPEB Trust Fund

Article 48: To see if the Town will vote to raise and appropriate or transfer from available funds a sufficient sum of money to be added to the OPEB Trust Fund, and to act fully thereon. By the request of the Board of Selectmen. Estimated cost: \$###,###.

Explanation:

FINANCE COMMITTEE RECOMMENDS THIS ARTICLE BE ACCEPTED AND ADOPTED. VOTE: YES-#, NO-#

ROLL CALL VOTES:

Finance Committee:

To accept and adopt:

Yeas: # (number): [Members by Roll Call]

Nays: # (number): [Members by Roll Call]

Board of Selectmen:

To accept and adopt:

Yeas: # (number): [Members by Roll Call]

Nays: # (number): [Members by Roll Call]

Fund Prior Year's Unpaid Bills

Article 49: To see if the Town will vote to raise and appropriate or transfer from available funds a sufficient sum of money to pay unpaid bills of prior years as provided for in M.G.L.

Ch. 44, Section 64, and to act fully thereon. By request of the Finance Director. Estimated cost: \$#

Explanation:

FINANCE COMMITTEE RECOMMENDS THIS ARTICLE BE ACCEPTED AND ADOPTED. VOTE: YES-#, NO-#

ROLL CALL VOTES:

Finance Committee:

To accept and adopt:

Yeas: # (number): [Members by Roll Call]

Nays: # (number): [Members by Roll Call]

Board of Selectmen:

To accept and adopt:

Yeas: # (number): [Members by Roll Call]

Nays: # (number): [Members by Roll Call]

Promote the Town Of Harwich

Article 50: To see if the Town will vote to raise and appropriate and/or transfer from available funds a sufficient sum of money for the Harwich Chamber of Commerce to promote the Town and its businesses and cultural endeavors to advance economic development initiatives for and with the Town of Harwich. Said monies to be used to manage and fulfill year-round visitor/resident/business information services, to promote and market the Town, to generate and initiate materials and activities that encourage the establishment, growth and sustainability of businesses in Harwich, and to implement economic development objectives and activities in partnership with the Town, and to act fully thereon. By request of the Board of Selectmen. Estimated cost: \$30,000

Explanation: This is a customary article whereby the Town supports the efforts of the Harwich Chamber of Commerce in promoting the town widely and throughout the year.

FINANCE COMMITTEE RECOMMENDS THIS ARTICLE BE ACCEPTED AND ADOPTED. VOTE: YES-#, NO-#

ROLL CALL VOTES:

Finance Committee:

To accept and adopt:

Yeas: # (number): [Members by Roll Call]

Nays: # (number): [Members by Roll Call]

Board of Selectmen:

To accept and adopt:

Yeas: # (number): [Members by Roll Call]

Nays: # (number): [Members by Roll Call]

Defray the Expenses of The Chase Library and Harwich Port Library

Article 51: To see if the Town will vote to raise and appropriate and/or transfer from available funds the sum of \$20,000 to help defray the expenses of the Chase Library and the Harwich Port Library; said funds to be expended under the direction of the Chase Library and Harwich Port Library Trustees, and to act fully thereon. By request of the Board of Selectmen. Estimated cost: \$20,000

Explanation:

FINANCE COMMITTEE RECOMMENDS THIS ARTICLE BE ACCEPTED AND ADOPTED. VOTE: YES-#, NO-#

ROLL CALL VOTES:

Finance Committee:

To accept and adopt:

Yeas: # (number): [Members by Roll Call]

Nays: # (number): [Members by Roll Call]

Board of Selectmen:

To accept and adopt:

Yeas: # (number): [Members by Roll Call]

Nays: # (number): [Members by Roll Call]

Supplement Annual Allocation of Mass Cultural Council For
Local Cultural Council Grants

Article 52: To see if the Town will vote to raise and appropriate, transfer from available funds and/or borrow a sufficient sum of money to supplement the Massachusetts Cultural Council annual allocation for community grant awards to artists, performers, and interpretive scientists who bring events and programs to local venues which enhance the cultural experience of Harwich citizens of all ages, and to act fully thereon. By request of the Board of Selectmen and the Harwich Cultural Council. Estimated Cost: \$3,600.

Explanation:

FINANCE COMMITTEE RECOMMENDS THIS ARTICLE BE ACCEPTED AND ADOPTED. VOTE: YES-#, NO-#

ROLL CALL VOTES:

Finance Committee:

To accept and adopt:

Yeas: # (number): [Members by Roll Call]

Nays: # (number): [Members by Roll Call]

Board of Selectmen:

To accept and adopt:

Yeas: # (number): [Members by Roll Call]

Nays: # (number): [Members by Roll Call]

Herring Fisheries

Article 53: To see what action the Town will take in regard to the Herring Fisheries and to act fully thereon. Customary Article.

FINANCE COMMITTEE RECOMMENDS THIS ARTICLE BE ACCEPTED AND ADOPTED. VOTE: YES-#, NO-#

ROLL CALL VOTES:

Finance Committee:

To accept and adopt:

Yeas: # (number): [Members by Roll Call]

Nays: # (number): [Members by Roll Call]

Board of Selectmen:

To accept and adopt:

Yeas: # (number): [Members by Roll Call]

Nays: # (number): [Members by Roll Call]

Amend the Code of The Town Of Harwich Charter - Update "Board of Selectmen" To
"Select Board"

Article 54: To see if the Town will vote to propose the following amendment to the Harwich Home Rule Charter, to be approved by the voters at the next annual Town election as follows: (new text shown as underlined)

Amend Chapter 3, §1-1 as follows:

A board of selectmen of 5 members shall be elected at-large for 3-year overlapping terms. For purposes of this Charter, the Board of Selectmen shall be referred to as the Select Board.

The Select Board shall possess all of the authority and duties of a Board of Selectmen under the General laws, this Charter, and the bylaws of the Town.

And further, by deleting, in every other instance in which they appear, the words "Board of Selectmen" and inserting in their place, the words, "Select Board", and to act fully thereon. By the Board of Selectmen.

Explanation: To amend the charter to reflect that not only men are elected to the Board of Selectmen and to ensure that the Town is viewed as inclusive to all. These amendments will be subject to approval by the voters at the 2022 Annual Town Election if adopted at this town meeting. Additional changes to General and/or Zoning Bylaws would follow on these Charter amendments.

FINANCE COMMITTEE RECOMMENDS THIS ARTICLE BE ACCEPTED AND ADOPTED. VOTE: YES-#, NO-#

ROLL CALL VOTES:

Finance Committee:

To accept and adopt:

Yeas: # (number): [Members by Roll Call]

Nays: # (number): [Members by Roll Call]

Board of Selectmen:

To accept and adopt:

Yeas: # (number): [Members by Roll Call]

Nays: # (number): [Members by Roll Call]

Hereof fail not and make return of this warrant with your doings thereon at the time and place of said voting.

Given under our hands this 29th day of March, 2021.

Larry G. Ballantine, Chair

Stephen P. Ford, Vice Chair

Michael D. MacAskill, Clerk

Donald F. Howell

Edward J. McManus

Board of Selectmen
Town of Harwich

A true copy Attest:

Constable

**COMMONWEALTH OF MASSACHUSETTS
TOWN OF HARWICH
ANNUAL ELECTION BALLOT
MAY 21, 2019**

BARNSTABLE, ss:

To either of the Constables of the Town of Harwich in said County,

Greetings:

In the name of the Commonwealth of Massachusetts you are hereby directed to notify and warn the inhabitants of said Town qualified to vote in elections and Town affairs to meet in the Community Center Gymnasium, 100 Oak Street, in said Town on Tuesday, May 21, 2019, then and there to act on the following ballot:

POLLS WILL BE OPEN AT 7:00 A.M. and CLOSE AT 8:00 P.M.

To choose on one (1) ballot the following Town Officers and Committees: two (2) Selectmen for three (3) years; one (1) Town Clerk for three (3) years; one (1) Monomoy Regional School Committee Member for three (3) years; one (1) Monomoy Regional School Committee Member to fill a 1-year unexpired term; two (2) Library Trustees for three (3) years; one (1) Water Commissioner for three (3) years; one (1) Housing Authority member to fill a 2-year unexpired term

BALLOT QUESTIONS

1. Shall the Town of Harwich be allowed to exempt from the provisions of Proposition 2 1/2, so called, the amounts required to pay for the bond issued in order to fund the Reconstruction of Lower County Road including all costs incidental and related thereto, as requested in the Capital Plan for FY20?

YES _____ NO _____

2. Shall the Town of Harwich be allowed to exempt from the provisions of Proposition 2 1/2, so called, the amounts required to pay for the bond issued in order to fund the Road Maintenance Program, including, but not limited to Lower County Road and other roads on the Program, and all costs incidental and related thereto, as requested in the Capital Plan for FY20?

YES _____ NO _____

Hereof fail not and make return of this warrant with your doings thereon at the time and place of said voting.

Given under our hands this 29th day of March, 2021.

Larry G. Ballantine, Chair

Stephen P. Ford, Vice Chair

Michael D. MacAskill, Clerk

Donald F. Howell

Edward J. McManus

Board of Selectmen
Town of Harwich

A true copy Attest:

Constable

ART #	SPONSOR	PURPOSE	AMOUNT	SOURCE	BOS	FinCOM	Notes
1	Customary	Choose Officers & Committees	-	N/A			
2	Customary	Reports of Officers & Committees	-	N/A			
3	Customary	Elected Officials Salaries	\$118,503				
4	Board of Selectmen	Town Operating Budget	\$39,027,463	Various			
5	MRSC	MRSD Budget	\$27,361,049				
6	Cape Cod Regional Technical District	Cape Cod Regional School Budget	\$1,536,309				
7	Water & Wastewater Commission	Water Department Budget	\$4,223,405				
8	Water & Wastewater Commission	Wastewater Department Budget	\$515,331				
9	Board of Selectmen	PEG Access & Cable Related Fund for Cable Access	\$150,994	PEG			
10	Board of Selectmen	Lease Purchase Agreements					
11	Board of Selectmen	Adopt the Capital Plan					
12	Board of Selectmen	Capital Items under \$50K Free Cash	\$18,000	Free Cash			CAPITAL OUTLAY PLAN EXPENDITURES
13	Board of Selectmen	COP: Harwich Center Sidewalks	\$50,000	Free Cash			
14	Board of Selectmen	COP: Rte 28/Harbor Sidewalks	\$200,000	Free Cash			
15	Board of Selectmen	COP: Engineering/MS4	\$200,000	Free Cash			
16	Board of Selectmen	COP: Brooks Library Roof	\$148,500	Free Cash			
17	Board of Selectmen	COP: 5 Bells Neck Roof	\$50,000	Free Cash			
18	Board of Selectmen	COP: Public Safety Radios	\$223,204	Free Cash			
19	Board of Selectmen	COP: Pumper/Ladder Truck	\$1,138,000	DE			
20	Board of Selectmen	COP: DPW Roads Maintenance Plan	\$700,000	DE			
21	Board of Selectmen	COP: DPW Vehicles	\$460,000	Free Cash			
22	Board of Selectmen	COP: Hearing Room & Studio Improvements	\$99,254	PEG			
23	Board of Selectmen	COP: Land acquisitions for protection of water supply	\$175,000	RE			
24	Board of Selectmen	COP: New source exploration	\$250,000	RE			
25	Board of Selectmen	COP: Route 28 Water Main Replacement Design	\$500,000	RE			
26	Board of Selectmen	COP: Station 8 Generator	\$50,000	RE			
27	Community Preservation Committee	Appropriate sums of money from the FY 2022 Estimated Annual Revenues of the Community Preservation Act Funds		CPC			
28	Community Preservation Committee	Fund Land Bank Debt Services	\$233,050	CPC			
29	Community Preservation Committee	Community Preservation Activities Under \$50,000	\$127,066	CPC			

ART #	SPONSOR	PURPOSE	AMOUNT	SOURCE	BOS	FinCOM	Notes
30	Community Preservation Committee	East Harwich Methodist Cemetery Preservation Project	\$112,200	CPC			COMMUNITY PRESERVATION ARTICLES
31	Community Preservation Committee	Brooks Academy Structural Improvements Project	\$1,150,000	CPC			
32	Community Preservation Committee	Funding for the Part-time Housing Coordinator	\$50,000	CPC			
33	Community Preservation Committee	Hinckleys Pond Watershed Preservation Project	\$360,000	CPC			
34	Community Preservation Committee	Harwich Natural Heritage Trail Project	\$150,000	CPC			
35	Community Preservation Committee	Brooks Park Lighting Project	\$125,000	CPC			
36	Community Preservation Committee	Sand Pond Revitalization Project	\$83,500	CPC			
37	Board of Selectmen	Amend Ch. 9 Capital (5 yr plan)					Amend Charter
38	Planning Board/Board of Selectmen	Amend §325-42.L Parking					Amend Zoning
39	Planning Board/Board of Selectmen	West Harwich Special District Design Guidelines					Amend Zoning
40	Conservation Commission	Amend GBL Ch. 304 Water Dependent Structures					Amend General Bylaw
41	Conservation Commission	Amend GBL Ch. 310 Wetlands Protection Bylaw					Amend General Bylaw
42	Historic District/Historical Commission	Amend GBL, Ch. 131, Historic Preservation					Amend General Bylaw
43	Board of Selectmen	Approve DHY Partnership Agreement					
44	Board of Selectmen	Rescind past articles and authorize sale of 5 Bells Neck Road					
45	Board of Selectmen	Amend GBL, Ch. 8 Departmental Revolving Funds					Amend General Bylaw
46	Board of Selectmen	Annual Departmental Revolving Fund Authorization					Revolving Fund
47	Board of Selectmen	Stabilization Fund					
48	Board of Selectmen	OPEB Trust Fund					
49	Board of Selectmen	Prior Year's Unpaid Bills					
50	Board of Selectmen	Promote the Town of Harwich	\$30,000	Free Cash			Customary Articles
51	Board of Selectmen	Defray costs for Other Libraries	\$20,000	Free Cash			
52	Board of Selectmen	Supplemental Allocation for Local Cultural Council	\$3,600	Free Cash			
53	Board of Selectmen	Herring Fisheries					
54	Board of Selectmen	Amend to Select Board					

**ANNUAL TOWN MEETING
WARRANT
With
RECOMMENDATIONS**

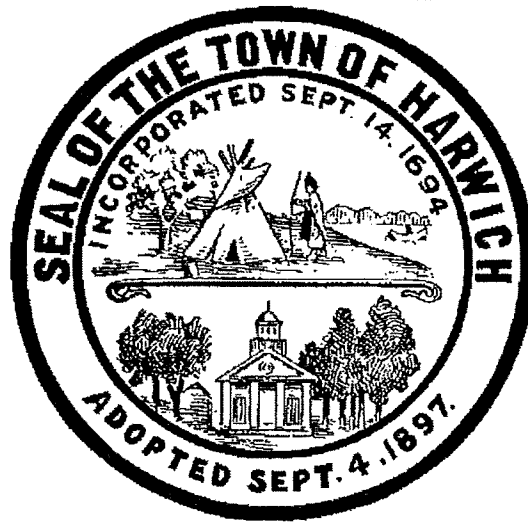

**Saturday, May 8, 2021
10:00AM
Monomoy Regional High School
Stadium Field
75 Oak Street**

Face coverings - mandatory

Rain Date – Saturday, May 15, 2021; 10:00AM

TABLE OF CONTENTS
ANNUAL TOWN MEETING
May 8, 2021

Procedures.....	1
Motion Chart.....	2
Tax Rate Chart.....	3
Municipal Finance Terms Voting.....	4
Proposition 2 ½ Terms.....	5
Municipal Finance Terms for Capital Improvements.....	6
Article #.....	
Article #.....	
Article #.....	
Article #.....	
Article #.....	
Article #.....	
Article #.....	
Article #.....	
Article #.....	
Article #.....	
Article #.....	
Article #.....	
Article #.....	
Article #.....	
Article #.....	
Article #.....	
Article #.....	
Article #.....	
Article #.....	
Article #.....	
Article #.....	
Article #.....	
Article #.....	
Article #.....	
Article #.....	
Article #.....	
Article #.....	
Article #.....	
Article #.....	
Article #.....	
Article #.....	
Article #.....	
Article #.....	
Article #.....	
Article #.....	
Article #.....	
Article #.....	
Article #.....	

Article #.....
Article #.....
Article #.....
Article #.....
Article #.....
Article #.....
Article #.....
Article #.....
Article #.....
Article #.....
Article #.....
Article #.....
Article #.....
Article #.....
Article #.....

APPENDIX A – Annual Town Election Ballot

APPENDIX B – Budget

APPENDIX C – Capital Plan

VOTING PROCEDURES

- I A quorum, 150 registered voters, must be present in order to conduct business. The only motion in order when no quorum is present is a motion to adjourn.
- II A two-thirds majority of the Town Meeting shall be required for inclusion of any Capital Outlay, unless it was included in the Capital Outlay Plan adopted at the preceding Town Meeting.
- III All motions introduced at the Town Meeting shall be in writing when required by the Moderator.
- IV Voters are limited to two times speaking on any one question; the total time speaking not to exceed 10 minutes.
- V Only registered voters shall occupy the meeting “floor”.
- VI No voter will be allowed to speak until he or she is recognized by the Moderator.
- VII Motion requiring more than a simple majority to pass:
 - A. To reconsider a vote on a motion – $\frac{3}{4}$ majority (this motion must be made prior to the next adjournment of the meeting).
 - B. To consider articles in an order other than as appears on the warrant – $\frac{3}{4}$ majority.
 - C. To pay unpaid bills – $\frac{4}{5}$ majority at the Annual Town Meeting, $\frac{9}{10}$ majority at a Special Town Meeting.
 - D. To move the previous question (terminate debate) – $\frac{3}{4}$ majority.
- VIII Quorum cannot be questioned after a motion has been made and seconded.

MOTION CHART Section 1-211
 (Application of Rules is indicated by an X)

Motions	Debatable	Non Debatable	Amendable	Non Amendable	Second Required	Second Not Required	Majority Vote	2/3 Vote	¾ Vote	May Reconsider	Cannot Reconsider
Adjourn		X		X	X		X				X
Adjourn (in a time certain)	X		X		X		X			X	
Amendment	X		X		X		X			X	
Adopt a Resolution	X		X		X		X				X
Accept & Adopt	X		X		X		X ¹			X	
Postpone Indefinitely	X			X	X		X			X	
Previous Question Terminate Debate		X		X	X			X			X
Reconsider ²	X			X	X			X			X
Consider Articles Out of Order	X		X		X			X			X
Point of Order		X					X				
1. Unless a greater than simple majority required by General Laws of Town of Harwich by-laws.											
2. See section 1.207											

TAX RATE CHART

THE CHART BELOW SHOWS THE AMOUNT OF MONEY REQUIRED TO CHANGE
THE FY 2022 TAX RATE

TAX RATE CHANGE IN \$/1000	DOLLARS REQUIRED
\$0.01	\$56,835
\$0.05	\$284,175
\$0.10	\$568,349
\$0.15	\$852,524
\$0.20	\$1,136,699
\$0.25	\$1,420,874
\$0.30	\$1,705,048
\$0.35	\$1,989,223
\$0.40	\$2,273,398
\$0.45	\$2,557,572
\$0.50	\$2,841,747
\$0.55	\$3,125,922
\$0.60	\$3,410,096
\$0.65	\$3,694,271
\$0.70	\$3,978,446
\$0.75	\$4,262,621
\$0.80	\$4,546,795
\$0.85	\$4,830,970
\$0.90	\$5,115,145
\$0.95	\$5,399,319
\$1.00	\$5,683,494

MUNICIPAL FINANCE TERMS

APPROPRIATION: An authorization granted by a town meeting, city council or other legislative body to expend money and incur obligations for specific public purposes. An appropriation is usually limited in amount and as to the time period within which it may be expended.

AVAILABLE FUNDS: Balances in the various fund types that represent nonrecurring revenue sources. As a matter of sound practice, they are frequently appropriated for unforeseen expenses, capital expenditures, or other one-time costs. Examples of available funds include free cash, stabilization funds, overlay surplus, water surplus, and retained earnings.

CHERRY SHEET: Named for the cherry-colored paper on which they were originally printed, the Cherry Sheet is the official notification to cities, towns, and regional school districts of the next fiscal year's state aid and assessments. The aid is in the form of distributions, which provide funds based on formulas and reimbursements that provide funds for costs incurred during a prior period for certain programs or services.

FREE CASH: Remaining, unrestricted funds from operations of the previous fiscal year, including unexpended free cash from the previous year, actual receipts in excess of revenue estimated on the tax recapitulation sheet, and unspent amounts in budget line items. Unpaid property taxes and certain deficits reduce the amount that can be certified as free cash.

OVERLAY (Overlay Reserve, or Allowance for Abatements and Exemptions): An account that funds anticipated property tax abatements, exemptions, and uncollected taxes. Additions to the overlay reserve need not be funded by the normal appropriation process but instead raised on the tax rate recapitulation sheet.

RESERVE FUND: An amount (not to exceed 5 percent of the tax levy for the preceding year) set aside annually within a community's budget to provide a funding source for extraordinary or unforeseen expenditures. In a town, the finance committee can authorize transfers from this fund for "extraordinary or unforeseen" expenditures. Other uses of the fund require budgetary transfers by town meeting.

STABILIZATION FUND: A fund designed to accumulate amounts for capital and other future spending purposes, although it may be appropriated for any lawful purpose (MGL c. 40 § 5B). Communities may establish one or more stabilization funds for different purposes and may appropriate any amounts into them. A two-thirds vote of town meeting is required to establish, amend the purpose of, or appropriate money from a stabilization fund. A majority vote of town meeting is required to appropriate money into a stabilization fund.

MUNICIPAL FINANCE TERMS RELATED TO CAPITAL IMPROVEMENTS

CAPITAL ASSETS: – Any tangible property used in the operation of government that is not easily converted into cash and that has an initial useful life extending beyond a single financial reporting period. Capital assets include land and land improvements; infrastructure, such as roads, bridges, water and sewer lines; easements; buildings and building improvements; vehicles, machinery and equipment. Communities typically define capital assets in terms of a minimum useful life and minimum initial cost.

CAPITAL BUDGET: An appropriation or spending plan that uses borrowing or direct outlay for capital or fixed asset improvements. Among other information, a capital budget should identify the method to finance each recommended expenditure (e.g., tax levy or rates) and identify those items that were not recommended.

CAPITAL IMPROVEMENTS PROGRAM: – A blueprint for planning a community's capital expenditures that comprises an annual capital budget and a five-year capital plan. It coordinates community planning, fiscal capacity, and physical development. While all the community's needs should be identified in the program, there is a set of criteria that prioritize the expenditures.

CAPITAL OUTLAY: The exchange of one asset (cash) for another (capital asset) with no ultimate effect on net assets. Also known as "pay as you go," it is the appropriation and use of available cash to fund a capital improvement, as opposed to incurring debt to cover the cost.

FIXED ASSETS: – Long-lived, tangible assets, such as buildings, equipment and land, obtained or controlled as a result of past transactions or circumstances.

MUNICIPAL FINANCE TERMS RELATED TO PROPOSITION 2 ½ TERMS

Chapter 59, Section 21C of the Massachusetts General Laws commonly referred to as Proposition 2 ½ (Prop. 2 ½) or the Tax Limiting Law for Cities and Towns in Massachusetts.

CAPITAL OUTLAY EXPENDITURE EXCLUSION: A temporary increase in the tax levy to fund a capital project or to make a capital acquisition. Such an exclusion requires a two-thirds vote of the selectmen or city council (sometimes with the mayor's approval) and a majority vote in a communitywide referendum. The exclusion is added to the tax levy only during the year in which the project is being funded and may increase the tax levy above the levy ceiling.

CONTINGENT APPROPRIATION: An appropriation that authorizes spending for a particular purpose only if subsequently approved in a voter referendum. Under MGL c. 59 § 21C (m), towns may make appropriations from the tax levy, available funds, or borrowing contingent on the subsequent passage of a Proposition 2½ override or exclusion question for the same purpose. If initially approved at an annual town meeting, voter approval of the contingent appropriation must occur by September 15. Otherwise, the referendum vote must occur within 90 days after the town meeting dissolves. The question may be placed before the voters at more than one election, but if the appropriation is not approved by the applicable deadline, it is null and void. If contingent appropriations are funded through

property taxes, DLS cannot approve the tax rate until the related override or exclusion question is resolved or the deadline passes, whichever occurs first.

DEBT EXCLUSION: An action taken by a community through a referendum vote to raise the funds necessary to pay debt service costs for a particular project from the property tax levy but outside of the limits under Proposition 2^{1/2}. By approving a debt exclusion, a community calculates its annual levy limit under Proposition 2^{1/2}, then adds the excluded debt service cost. The amount is added to the levy limit for the life of the debt only and may increase the levy above the levy ceiling.

LEVY: The amount a community raises through the property tax. The levy can be any amount up to the levy limit, which is reestablished every year in accordance with Proposition 2^{1/2} provisions.

LEVY CEILING: – A levy ceiling is one of two types of levy (tax) restrictions imposed by MGL c. 59 § 21C (Proposition 2^{1/2}). It states that, in any year, the real and personal property taxes imposed may not exceed 2^{1/2} percent of the total full and fair cash value of all taxable property. Property taxes levied may exceed this limit only if the community passes a capital exclusion, debt exclusion, or special exclusion.

LEVY LIMIT: A levy limit is one of two types of levy (tax) restrictions imposed by MGL c. 59 § 21C (Proposition 2^{1/2}). It states that the real and personal property taxes imposed by a city or town may only grow each year by 2^{1/2} percent of the prior year's levy

NEW GROWTH: The additional tax revenue generated by new construction, renovations and other increases in the property tax base during a calendar year. It does not include value increases caused by normal market forces or revaluations.

OVERRIDE: A vote by a community at an election to permanently increase the levy limit. An override vote may increase the levy limit no higher than the levy ceiling. The override question on the election ballot must state a purpose for the override and the dollar amount.

OVERRIDE CAPACITY: The difference between a community's levy ceiling and its levy limit. It is the maximum amount by which a community may override its levy limit.

Note: The glossary definitions found on pages 4, 5 and 6 of this Warrant were derived from the *Municipal Glossary* published the Division of Local Services (January 2020).

The entire glossary can be found at:

<https://www.mass.gov/info-details/municipal-governance-training-and-resources>

**COMMONWEALTH OF MASSACHUSETTS
TOWN OF HARWICH
ANNUAL TOWN MEETING
May 8, 2021**

BARNSTABLE, ss:

To either of the Constables of the Town of Harwich in said county,

Greetings:

In the name of the Commonwealth of Massachusetts you are hereby directed to notify and warn the inhabitants of said Town qualified to vote in elections and Town affairs to meet at the Monomoy Regional High School Stadium Field, 75 Oak Street in said Town on Saturday, May 8, 2021 at 10:00 A.M., then and there to act on the following articles:

ARTICLES

TOWN OFFICERS AND COMMITTEES

ARTICLE 1: To choose various Town Officers and Committees.

FINANCE COMMITTEE RECOMMENDS THIS CUSTOMARY ARTICLE BE ACCEPTED AND ADOPTED. VOTE: YES-#, NO-#

ROLL CALL VOTES:

Finance Committee:

To accept and adopt:

Yeas: # (number): [Members by Roll Call]

Nays: # (number): [Members by Roll Call]

Board of Selectmen:

To accept and adopt:

Yeas: # (number): [Members by Roll Call]

Nays: # (number): [Members by Roll Call]

REPORTS OF TOWN OFFICERS AND COMMITTEES

ARTICLE 2: To hear reports of all Town Officers and Committees for the year 2020.

FINANCE COMMITTEE RECOMMENDS THIS CUSTOMARY ARTICLE BE ACCEPTED AND ADOPTED. VOTE: YES-#, NO-#

ROLL CALL VOTES:

Finance Committee:

To accept and adopt:

Yeas: # (number): [Members by Roll Call]

Nays: # (number): [Members by Roll Call]

Board of Selectmen:

To accept and adopt:

Yeas: # (number): [Members by Roll Call]

Nays: # (number): [Members by Roll Call]

ELECTED OFFICIALS SALARIES

ARTICLE 3: To see if the Town will vote the salaries of the Elected Officials of the Town for fiscal year commencing July 1, 2021 and ending June 30, 2022 as follows and to act fully thereon. Estimated cost: \$118,503.00.

Selectmen (5)	\$2,400 each
Moderator	\$1,000
Water & Wastewater Commissioners (5)	\$1,000 each
Library Trustees (7)	\$1,000 each
Town Clerk	\$103,503

FINANCE COMMITTEE RECOMMENDS THIS ARTICLE BE ACCEPTED AND ADOPTED. VOTE: YES-#, NO-#

ROLL CALL VOTES:

Finance Committee:

To accept and adopt:

Yeas: # (number): [Members by Roll Call]

Nays: # (number): [Members by Roll Call]

Board of Selectmen:

To accept and adopt:

Yeas: # (number): [Members by Roll Call]

Nays: # (number): [Members by Roll Call]

TOWN OPERATING BUDGET

ARTICLE 4: To see if the Town will vote to raise and appropriate, transfer from available funds or borrow such sums of money as may be required to defray Town charges for Fiscal Year 2022, and to act fully thereon. By request of the Board of Selectmen. (BUDGET – APPENDIX B). Estimated Cost: \$39,027,463.00.

OPERATING BUDGET	
Betterments	\$61,287
Cable Fund	\$210,100
Community Preservation Act (CPA)	\$233,050
FEMA	\$13,855
Free Cash	\$560,331
Golf Improvement	\$104,950
Overlay Surplus	\$200,000
State Aid	\$667,067
Water Enterprise	\$727,304
Wastewater Enterprise	\$31,446
SUBTOTAL	\$2,809,390
Local Receipts	\$12,680,198
Taxes	\$23,537,875
OPERATING BUDGET	\$39,027,463

FINANCE COMMITTEE RECOMMENDS THIS ARTICLE BE ACCEPTED AND ADOPTED. VOTE: YES-#, NO-#

ROLL CALL VOTES:

Finance Committee:

To accept and adopt:

Yeas: # (number): [Members by Roll Call]

Nays: # (number): [Members by Roll Call]

Board of Selectmen:

To accept and adopt:

Yeas: # (number): [Members by Roll Call]

Nays: # (number): [Members by Roll Call]

MONOMOY REGIONAL SCHOOL DISTRICT BUDGET

ARTICLE 5: To see if the Town will vote to raise and appropriate, transfer from available funds or borrow such sums of money as may be required to pay for the Monomoy Regional School District Assessment for Fiscal Year 2022, and to act fully thereon. By request of the Monomoy Regional School Committee. Estimated cost: \$27,361,049.00.

MONOMOY REGIONAL SCHOOL DISTRICT BUDGET	
Operating Budget	\$25,043,128
Transportation	\$591,564
Capital	\$273,260
Debt	\$1,453,097
TOTAL	\$27,361,049

FINANCE COMMITTEE RECOMMENDS THIS ARTICLE BE ACCEPTED AND ADOPTED. VOTE: YES-#, NO-#

ROLL CALL VOTES:

Finance Committee:

To accept and adopt:

Yeas: # (number): [Members by Roll Call]

Nays: # (number): [Members by Roll Call]

Board of Selectmen:

To accept and adopt:

Yeas: # (number): [Members by Roll Call]

Nays: # (number): [Members by Roll Call]

CAPE COD REGIONAL TECHNICAL SCHOOL DISTRICT BUDGET

ARTICLE 6: To see if the Town will vote to raise and appropriate, transfer from available funds or borrow a sufficient sum of money as may be required to pay for the Cape Cod Regional Technical High School District Assessment for Fiscal Year 2021, and to act fully thereon. By request of the Cape Cod Regional Technical High School District. Estimated cost: \$1,536,309.00.

CAPE COD REGIONAL TECHNICAL SCHOOL DISTRICT BUDGET	
Operating Budget	\$1,026,670
Debt	\$509,639
TOTAL	\$1,536,309

FINANCE COMMITTEE RECOMMENDS THIS ARTICLE BE ACCEPTED AND ADOPTED. VOTE: YES-#, NO-#

ROLL CALL VOTES:

Finance Committee:

To accept and adopt:

Yeas: # (number): [Members by Roll Call]

Nays: # (number): [Members by Roll Call]

Board of Selectmen:

To accept and adopt:

Yeas: # (number): [Members by Roll Call]

Nays: # (number): [Members by Roll Call]

WATER DEPARTMENT BUDGET

ARTICLE 7: To see if the Town will vote to raise and appropriate, transfer from available funds or borrow such sums of money as may be required to defray the Water Department Operating Budget for Fiscal Year 2022, and to act fully thereon. By request of the Water and Wastewater Commission. Estimated cost: \$4,223,405.00.

WATER OPERATING BUDGET	
Salaries	\$1,279,529
Expenses	\$1,462,195
Debt	\$704,377
Indirect Costs	\$727,304
OPEB	\$50,000
TOTAL	\$4,223,405

FINANCE COMMITTEE RECOMMENDS THIS ARTICLE BE ACCEPTED AND ADOPTED. VOTE: YES-#, NO-#

ROLL CALL VOTES:

Finance Committee:

To accept and adopt:

Yeas: # (number): [Members by Roll Call]

Nays: # (number): [Members by Roll Call]

Board of Selectmen:

To accept and adopt:

Yeas: # (number): [Members by Roll Call]

Nays: # (number): [Members by Roll Call]

WASTEWATER DEPARTMENT BUDGET

ARTICLE 8: To see if the Town will vote to raise and appropriate, transfer from available funds or borrow such sums of money as may be required to defray the Wastewater Department Operating Budget for Fiscal Year 2022, and to act fully thereon. By request of the Water and Wastewater Commission. Estimated cost: \$515,331.00.

WASTEWATER OPERATING BUDGET	
Salaries	\$78,099
Expenses	\$405,786
Indirect Costs	\$31,446
TOTAL	\$515,331

FINANCE COMMITTEE RECOMMENDS THIS ARTICLE BE ACCEPTED AND ADOPTED. VOTE: YES-#, NO-#

ROLL CALL VOTES:

Finance Committee:

To accept and adopt:

Yeas: # (number): [Members by Roll Call]

Nays: # (number): [Members by Roll Call]

Board of Selectmen:

To accept and adopt:

Yeas: # (number): [Members by Roll Call]

Nays: # (number): [Members by Roll Call]

Public, Education & Government (PEG) Access and Cable Related Fund for Public Access

ARTICLE 9: To see if the Town vote to transfer from the PEG Access and Cable Related Fund such sums of money that may be required for the purpose of funding the public access station, Cape Cod Community Media Center, 17 Shad Hole Rd. Dennis Port, MA 02639. Providing the public access television to the citizens of Harwich. By request of the Board of Selectmen.

Estimated Cost: \$150,994.00

Explanation: To be funded from the PEG Access and Cable Related Fund. The Town of Harwich receives funding from Comcast subscriber fees to fund and maintain Public, Education and Government television stations (PEG access). Under a new agreement with Comcast the Town will allocate funds directly to Cape Cod Community Media Center. The funding was previously paid directly from Comcast. The appropriation sum has been based on FY20 actual revenue into the fund.

FINANCE COMMITTEE RECOMMENDS THIS ARTICLE BE ACCEPTED AND ADOPTED. VOTE: YES-#, NO-#

ROLL CALL VOTES:

Finance Committee:

To accept and adopt:

Yeas: # (number): [Members by Roll Call]

Nays: # (number): [Members by Roll Call]

Board of Selectmen:

To accept and adopt:

Yeas: # (number): [Members by Roll Call]

Nays: # (number): [Members by Roll Call]

Lease Purchase Agreements

ARTICLE 10: To see if the Town will vote to enter into various lease purchase financing agreements for town equipment included in the operating budget for FY 2022, said leases may be for a term not to exceed the useful life of the equipment as determined by the Board of Selectmen; or to act fully thereon. By request of the Board of Selectmen.

Explanation:

The Municipal Modernization Act of 2016 allows the Town to enter into a tax exempt lease purchase agreement for a period in excess of three years as a means of financing equipment purchases. The statute requires a recommendation by the Town Administrator and a two-thirds vote of Town Meeting.

FINANCE COMMITTEE RECOMMENDS THIS ARTICLE BE ACCEPTED AND ADOPTED. VOTE: YES-#, NO-#

ROLL CALL VOTES:

Finance Committee:

To accept and adopt:

Yeas: # (number): [Members by Roll Call]

Nays: # (number): [Members by Roll Call]

Board of Selectmen:

To accept and adopt:

Yeas: # (number): [Members by Roll Call]

Nays: # (number): [Members by Roll Call]

Adopt the Capital Plan

ARTICLE 11: To see if the Town will vote to adopt the Capital Plan for the ensuing five year period as proposed by the Board of Selectmen and set forth below or as amended by vote of the Town Meeting, and to act fully thereon. By request of the Board of Selectmen.

CAPITAL PLAN (APPENDIX C)

Explanation: Sections 5 and 6 of Chapter 9 of the Harwich Charter were amended by the voters at the 2020 Annual Town Election. Article 33 of this Town Meeting will codify the intent of Article 36 from the 2019 Annual Town Meeting to establish a Five (5) Year Capital Plan. At the direction of the Town Administrator, the Capital Outlay Committee established a Five (5) Year Plan covering Fiscal Years 2022 through 2026 for adoption at this Town Meeting.

FINANCE COMMITTEE RECOMMENDS THIS ARTICLE BE ACCEPTED AND ADOPTED. VOTE: YES-#, NO-#

ROLL CALL VOTES:

Finance Committee:

To accept and adopt:

Yeas: # (number): [Members by Roll Call]

Nays: # (number): [Members by Roll Call]

Board of Selectmen:

To accept and adopt:

Yeas: # (number): [Members by Roll Call]

Nays: # (number): [Members by Roll Call]

Capital Items Funded From Free Cash – Items under \$50,000

ARTICLE 12: To see if the Town will vote to raise and appropriate, transfer from available funds or borrow a sufficient sum of money to fund the items in the table below included in the FY 2022 Capital Plan, and to act fully thereon. By request of the Board of Selectmen. Estimated cost: \$18,000.00

Department	Description	Amount
Police	Digital Fingerprint Machine (regular replacement)	\$18,000.00

Explanation:

FINANCE COMMITTEE RECOMMENDS THIS ARTICLE BE ACCEPTED AND ADOPTED. VOTE: YES-#, NO-#

ROLL CALL VOTES:

Finance Committee:

To accept and adopt:

Yeas: # (number): [Members by Roll Call]

Nays: # (number): [Members by Roll Call]

Board of Selectmen:

To accept and adopt:

Yeas: # (number): [Members by Roll Call]

Nays: # (number): [Members by Roll Call]

Funds for support of ADA-compliant sidewalks through Harwich Center

ARTICLE 13: To see if the Town will vote to raise and appropriate, transfer from available funds, or borrow a sufficient sum of money for the engineering and surveying services necessary for the preparation of plans and bid processes for proposed sidewalks from the

Community Center to the Cultural Center; and to act fully thereon. By request of the Board of Selectmen and the Capital Outlay Committee. Estimated cost: \$50,000.00

Explanation: This article resumes efforts to develop ADA-compliant sidewalks from Center (Community Center) to Center (Cultural Center) via Harwich Center. The town will pursue a Community Development Block Grant (CDBG) in FY 2022 when the grant program resumes. The funds from this article will support the necessary site plan design and preparations as well as initial bid process costs in anticipation of receiving a CDBG grant. This article builds upon the grant of \$142,021 received on March 3, 2021 from MA DOT Shared Streets Emergency Grant Program.

FINANCE COMMITTEE RECOMMENDS THIS ARTICLE BE ACCEPTED AND ADOPTED. VOTE: YES-#, NO-#

ROLL CALL VOTES:

Finance Committee:

To accept and adopt:

Yeas: # (number): [Members by Roll Call]

Nays: # (number): [Members by Roll Call]

Board of Selectmen:

To accept and adopt:

Yeas: # (number): [Members by Roll Call]

Nays: # (number): [Members by Roll Call]

Sidewalks from Saquatucket Harbor to Harwich Port

ARTICLE 14: To see if the Town will vote to raise and appropriate, transfer from available funds, or borrow a sufficient sum of money to restore funds for the Walkway Design & Construction Project from Saquatucket Harbor to Harwich Port; and to act fully thereon. By request of the Board of Selectmen and the Capital Outlay Committee. Estimated cost: \$200,000.00

Explanation: This articles restores most of the \$250,000.00 that was voted at the 2018 Annual Town Meeting and returned to the Town to offset a budget deficit exacerbated by COVID-19. The town recently received approval from the Commonwealth of Massachusetts' Department of Transportation to proceed with this project. This article supplements a gift to the town in support of this much-needed and oft-delayed project.

FINANCE COMMITTEE RECOMMENDS THIS ARTICLE BE ACCEPTED AND ADOPTED. VOTE: YES-#, NO-#

ROLL CALL VOTES:

Finance Committee:

To accept and adopt:

Yeas: # (number): [Members by Roll Call]

Nays: # (number): [Members by Roll Call]

Board of Selectmen:

To accept and adopt:

Yeas: # (number): [Members by Roll Call]

Nays: # (number): [Members by Roll Call]

Funds for the MS4 Mandated Stormwater Permitting and Management Program

ARTICLE 15: To see if the Town will vote to raise and appropriate, transfer from available funds, or borrow a sufficient sum of money to support the town's local stormwater permitting and program management; and to act fully thereon. By request of the Board of Selectmen and Capital Outlay Committee. Estimated cost: \$200,000.00.

Explanation: The articles funds the costs necessary for the ongoing stormwater permitting and management program as required by the MassDEP MS4 program.

FINANCE COMMITTEE RECOMMENDS THIS ARTICLE BE ACCEPTED AND ADOPTED. VOTE: YES-#, NO-#

ROLL CALL VOTES:

Finance Committee:

To accept and adopt:

Yeas: # (number): [Members by Roll Call]

Nays: # (number): [Members by Roll Call]

Board of Selectmen:

To accept and adopt:

Yeas: # (number): [Members by Roll Call]

Nays: # (number): [Members by Roll Call]

Brooks Free Library roof replacement

ARTICLE 16: To see if the Town will vote to raise and appropriate, transfer from available funds, or borrow a sufficient sum of money to repair and/or replace the Brooks Free Library roof; and to act fully thereon. By request of the Board of Selectmen. Estimated cost: \$148,500.00.

Explanation: The Brooks Free Library's roof was last updated in 1997 with 20-year shingles. This project was originally submitted for the FY 2020 Capital Plan and was deferred in FY 2021. The estimated costs at that time were \$135,000.00. This request assumes a 10% increase in costs of materials and prevailing wage rates on installation.

FINANCE COMMITTEE RECOMMENDS THIS ARTICLE BE ACCEPTED AND ADOPTED. VOTE: YES-#, NO-#

ROLL CALL VOTES:

Finance Committee:

To accept and adopt:

Yeas: # (number): [Members by Roll Call]

Nays: # (number): [Members by Roll Call]

Board of Selectmen:

To accept and adopt:

Yeas: # (number): [Members by Roll Call]

Nays: # (number): [Members by Roll Call]

Funds for roof repairs at 5 Bells Neck Road

ARTICLE 17: To see if the Town will vote to raise and appropriate, transfer from available funds, or borrow a sufficient sum of money to make necessary repairs to the roof of the building at 5 Bells Neck Road; and to act fully thereon. By request of the Board of Selectmen and the Capital Outlay Committee. Estimated cost: \$50,000.00.

Explanation: This article was deferred in FY 2021 due to the impact of COVID-19 on the overall budget process. The town is currently developing a "Request for Proposal (RFP)" for the sale pending the adoption of Article 42 at this Town Meeting which will rescind previous votes to lease and authorizing the Board of Selectmen to sell 5 Bells Neck Road as surplus property.

FINANCE COMMITTEE RECOMMENDS THIS ARTICLE BE ACCEPTED AND ADOPTED. VOTE: YES-#, NO-#

ROLL CALL VOTES:

Finance Committee:

To accept and adopt:

Yeas: # (number): [Members by Roll Call]

Nays: # (number): [Members by Roll Call]

Board of Selectmen:

To accept and adopt:

Yeas: # (number): [Members by Roll Call]

Nays: # (number): [Members by Roll Call]

Public safety radios

ARTICLE 18: To see if the Town will vote to raise and appropriate, transfer from available funds, or borrow a sufficient sum of money to purchase radios for the Fire Department and Police Department; and to act fully thereon. By request of the Board of Selectmen and the Capital Outlay Committee. Estimated cost: \$223,204.00.

Explanation: The radios used by both public safety departments need to be upgraded in conformity with state standards. The anticipated cost for the Police Department radios is \$74,165.00 and for the Fire Department is \$149,039.00 for a total radio replacement cost of \$223,204.00. The Fire Department has applied for a grant FY 2022 from the Commonwealth of MA to offset costs related to this mandated upgrade.

FINANCE COMMITTEE RECOMMENDS THIS ARTICLE BE ACCEPTED AND ADOPTED. VOTE: YES-#, NO-#

ROLL CALL VOTES:

Finance Committee:

To accept and adopt:

Yeas: # (number): [Members by Roll Call]

Nays: # (number): [Members by Roll Call]

Board of Selectmen:

To accept and adopt:

Yeas: # (number): [Members by Roll Call]

Nays: # (number): [Members by Roll Call]

Purchase of a combination Pumper/Ladder Fire Truck

ARTICLE 19: To see if the Town will vote to raise and appropriate, transfer from available funds, or borrow a sufficient sum of money to fund the purchase of combination pumper/ladder fire truck known as a Quint, and all costs incidental and related thereto. The appropriation authorized by this vote shall not take effect until the Town votes to exempt from the limitation on total taxes imposed by M.G.L. c.59 § 21c (Proposition 2 ½) the amounts required to pay the principal of and the interest on any borrowing authorized under this article. And further, in accordance with Chapter 44, Section 20 of the General Laws, the premium received by the Town upon the sale of any bonds or notes thereunder, less any such premium applied to the payment of the costs of issuance of such bonds or notes, may be applied to pay project costs and the amount authorized to be borrowed for each such project shall be reduced by the amount of any such premium so applied, and to act fully thereon. By request of the Board of Selectmen and Capital Outlay Committee. Estimated cost: \$1,138,000.00.

Explanation: The fire department, in an effort to relieve some financial pressure on the capital budget in FY 2020 and 2021, offered the following modification of the Capital plan: Remove the Engine replacement in FY20, accelerate the Ladder replacement in FY24 and purchase a Quint, a vehicle that performs the functions of a ladder and an Engine in FY21. By the time the FY21 budget was being prepared, the estimated cost of the quint had risen to 1.1 million. The manufacturer has indicated that another price increase will happen this month, and the new estimate is \$1,138,500.00. We are working with the representative and reviewing the specifications in the hopes of reducing that number. The passage of a debt

exclusion ballot question #1 at the Annual Town Election on Tuesday, May 18, 2021 is also necessary for the purchase of this item.

FINANCE COMMITTEE RECOMMENDS THIS ARTICLE BE ACCEPTED AND ADOPTED. VOTE: YES-#, NO-#

ROLL CALL VOTES:

Finance Committee:

To accept and adopt:

Yeas: # (number): [Members by Roll Call]

Nays: # (number): [Members by Roll Call]

Board of Selectmen:

To accept and adopt:

Yeas: # (number): [Members by Roll Call]

Nays: # (number): [Members by Roll Call]

Fund the FY 2022 Road Maintenance Program

ARTICLE 20: To see if the Town will vote to raise and appropriate, transfer from available funds, or borrow a sufficient sum of money to fund the Road Maintenance Program, and all costs incidental and related thereto. The appropriation authorized by this vote shall not take effect until the Town votes to exempt from the limitation on total taxes imposed by M.G.L. c.59 § 21c (Proposition 2 ½) the amounts required to pay the principal of and the interest on any borrowing authorized under this article. And further, in accordance with Chapter 44, Section 20 of the General Laws, the premium received by the Town upon the sale of any bonds or notes thereunder, less any such premium applied to the payment of the costs of issuance of such bonds or notes, may be applied to pay project costs and the amount authorized to be borrowed for each such project shall be reduced by the amount of any such premium so applied, and to act fully thereon. By request of the Board of Selectmen and the Capital Outlay Committee. Estimated cost: \$700,000.00.

Explanation: The capital request for road maintenance for FY 2022 is \$700,000.00. The town anticipates receiving a similar amount from Chapter 90 funds from the Commonwealth. The town's Chapter 90 apportionment for FY 2021 is \$676,736.00. There is a debt exclusion ballot question #2 regarding this article on the Annual Town Election ballot to be voted on May 18, 2021.

FINANCE COMMITTEE RECOMMENDS THIS ARTICLE BE ACCEPTED AND ADOPTED. VOTE: YES-#, NO-#

ROLL CALL VOTES:

Finance Committee:

To accept and adopt:

Yeas: # (number): [Members by Roll Call]

Nays: # (number): [Members by Roll Call]

Board of Selectmen:

To accept and adopt:

Yeas: # (number): [Members by Roll Call]

Nays: # (number): [Members by Roll Call]

Purchase and Equip Vehicles for the Department of Public Works

ARTICLE 21: To see if the Town will vote to raise and appropriate, transfer from available funds, or borrow a sufficient sum of money to purchase and equip the vehicles listed in the table below and further to authorize the Board of Selectmen to dispose of the vehicles listed in the table below if determined to be surplus property; and to act fully thereon. By request of the Board of Selectmen. Estimated cost: \$460,000.00.

Purchase and Equip Vehicles	
VEHICLE TYPE	ANTICIPATED COST
Front-End Loader	\$200,000.00
6 Wheel Dump Truck or equivalent	\$175,000.00
Ford F-150 Pickup Truck or equivalent	\$50,000.00
Ford E-250 Van or equivalent	\$35,000.00
TOTAL COST	\$460,000.00

Vehicles to be disposed of if determined to be surplus
1991 Elgin Premier
1996 L-70C Front End Loader
2005 Ford F-150
2006 Ford E-250 Van

Explanation: The 1999 Sterling Dump Truck is becoming extremely difficult to find parts for due to its age and the parts we do get are extremely expensive. The front end loader has over 30,000 hours of use or the equivalent of 1,200,000 miles on it. It has been a solid piece of equipment and served the Town well, but it is time to replace it. This is a front line piece of equipment that is used 362 days per year at the Disposal Area and helps generate the \$3.3M in revenue. The average yearly maintenance cost has been \$21,748, indicating that it is time to remove this loader from front line work. The 2005 F-150 is at the end of its useful life and has 191,102 miles on it. The frame on this 16 year old vehicle is rotted through and may not pass State safety inspections any longer. The 2006 Ford E-250 Building Maintenance van floors and body panels are rusted through. It is questionable whether it will pass a safety inspection this year.

FINANCE COMMITTEE RECOMMENDS THIS ARTICLE BE ACCEPTED AND ADOPTED. VOTE: YES-#, NO-#

ROLL CALL VOTES:

Finance Committee:

To accept and adopt:

Yeas: # (number): [Members by Roll Call]

Nays: # (number): [Members by Roll Call]

Board of Selectmen:

To accept and adopt:

Yeas: # (number): [Members by Roll Call]

Nays: # (number): [Members by Roll Call]

Public, Education & Government (PEG) Access and Cable Related Fund for Hearing Room & Studio Improvements

ARTICLE 22: To see if the Town will vote to transfer from the PEG Access and Cable Related Fund such sums of money that may be required to purchase and install studio cameras, lighting, video production hardware/software, and network peripherals in multiple hearing room locations for improved public meeting coverage. By request of the Board of Selectmen.

Estimated Cost: \$99,254.00

Explanation: To be funded from the PEG Access and Cable Related Fund.

FINANCE COMMITTEE RECOMMENDS THIS ARTICLE BE ACCEPTED AND ADOPTED. VOTE: YES-#, NO-#

ROLL CALL VOTES:

Finance Committee:

To accept and adopt:

Yeas: # (number): [Members by Roll Call]

Nays: # (number): [Members by Roll Call]

Board of Selectmen:

To accept and adopt:

Yeas: # (number): [Members by Roll Call]

Land acquisitions for the protection of well head and water supply

ARTICLE 23: To see if the Town will vote to authorize the Water and Wastewater Commission to acquire by purchase, gift, eminent domain, or otherwise, five parcels of land, all with an address of 0 Chatham Road, identified as Assessor's Owners Unknown Parcels 43-E7-0, 43-E9-0, 43-E9-A-0, 43-E10-0, and 43-E12-0, consisting of 15.34, acres more or less, said parcels to be placed under the care, custody, control, and management of the Water and Wastewater Commission and held for well head and water supply protection purposes; and further to appropriate from Certified Retained Earnings of the Water Enterprise Fund the sum of \$175,000 more or less, for said acquisition, including all costs incidental and related thereto; provided however that said appropriation shall be reduced by the amount of any gifts or grants received under the Cape Cod Commission DRI Grant program or any other grant program made available to the Town at the time of said acquisition; and further to authorize the Water and Wastewater Commission to apply for any such grants and to enter into all necessary agreements and to take such actions as may be necessary to carry out the purposes of this Article; or to act in relation thereto. By request of the Water and Wastewater Commission. Estimated Cost: \$99,254.00

Explanation: The Water Department is seeking funds to support the acquisition of 5 undeveloped parcels off Chatham Road totaling 7.67+/- acres abutting the Chatham Rd. wellfield. Acquisition of these parcels will further support the department's efforts to protect the water supply by limiting development immediately adjacent to the Chatham Road wellfield. The requested funds will be used to support the necessary title research and property acquisition. Funds used for the property acquisition are eligible for 100% reimbursement through Cape Cod Commission DRI funds.

FINANCE COMMITTEE RECOMMENDS THIS ARTICLE BE ACCEPTED AND ADOPTED. VOTE: YES-#, NO-#

ROLL CALL VOTES:

Finance Committee:

To accept and adopt:

Yeas: # (number): [Members by Roll Call]

Nays: # (number): [Members by Roll Call]

Board of Selectmen:

To accept and adopt:

Yeas: # (number): [Members by Roll Call]

Appropriate Sums of Money from the FY 2022 Estimated Annual Revenues of the
Community Preservation Act Fund

ARTICLE 24: To see if the Town will vote to appropriate the following sums of money from the FY 2022 estimated annual revenues of the Harwich Community Preservation Act Fund as required by the G.L. Chapter 44B and Chapter 149, §298 of the Acts of 2004 as follows:

- A sum of money for the acquisition, creation and preservation of the open space;
- A sum of money for the acquisition, preservation, restoration and rehabilitation of historic resources;
- A sum of money for the acquisition, creation, preservation and support of community housing; and
- A sum of money for the Community Preservation Act Fund FY2022 Undesignated Fund Balance (including Recreation)

and to act fully thereon. By request of the Community Preservation Committee.

<u>Appropriation</u>	<u>FY 2022</u>
Community Housing Reserve	\$154,126.00
Open Space Reserve	\$154,126.00
Historic Preservation Reserve	\$154,126.00
Undesignated Fund Balance Operating Expenses	\$25,000

Explanation:

FINANCE COMMITTEE RECOMMENDS THIS ARTICLE BE ACCEPTED AND ADOPTED. VOTE: YES-#, NO-#

ROLL CALL VOTES:

Finance Committee:

To accept and adopt:

Yeas: # (number): [Members by Roll Call]

Nays: # (number): [Members by Roll Call]

Board of Selectmen:

To accept and adopt:

Yeas: # (number): [Members by Roll Call]

Nays: # (number): [Members by Roll Call]

Fund Land Bank Debt Service

ARTICLE 25: To see if the Town will vote to appropriate from the Community Preservation Act Funds – \$51,692.06 from the Undesignated Fund Balance and \$181,357.94 from estimated annual revenue for Fiscal Year 2022 for a total of \$233,050 to fund the Land Bank Debt Service. Any funds left unspent from this Article are to be returned to the Community Preservation Act Funds – Undesignated Fund Balance, and to act fully thereon. By request of the Community Preservation Committee and the Finance Director. Estimated Cost: \$223,050.

FINANCE COMMITTEE RECOMMENDS THIS ARTICLE BE ACCEPTED AND ADOPTED. VOTE: YES-#, NO-#

ROLL CALL VOTES:

Finance Committee:

To accept and adopt:

Yeas: # (number): [Members by Roll Call]

Nays: # (number): [Members by Roll Call]

Board of Selectmen:

To accept and adopt:

Yeas: # (number): [Members by Roll Call]

Nays: # (number): [Members by Roll Call]

Community Preservation Activities under \$50,000

ARTICLE 26: To see if the Town will vote to appropriate from the Community Preservation Act Funds a sufficient sum of money to fund the items in the table below consistent with their respective applications, with each item considered a separate appropriation. Any funds left unspent from this Article are to be returned to the Community Preservation Act Fund from which the appropriation is made as specified in the chart below, and further authorize the Board of Selectmen to enter into grant agreements with the Cape

& Islands Veterans Outreach Center and Community Development Partnership, and to act fully thereon. By request of the Community Preservation Committee. Estimated Cost: \$127,066

Item #	Project	Purpose	Amount	Appropriation Source
1	Old Colony Rail Trail Harwich/Chatham Town Border marker project	To delineate town boundaries along the Old Colony Rail Trail	\$1,000.00	Estimated annual revenue for FY 2022
	Lower Cape Housing Institute	Ongoing support of the Cape Housing Institute	\$7,500.00	Community Housing Reserve
2	Crossing lights at Depot Road South	Ongoing effort to enhance safety through the Rail Trails	\$15,000.00	Estimated annual revenue for FY 2022
3	Veterans Home – Dennis, MA	Support the Cape & Islands Veterans Outreach Center's effort to creating housing; and to authorize the Board of Selectmen to enter into a grant agreement between the Town of Harwich and the Veteran's Outreach Center.	\$15,000.00	Estimated annual revenue for FY 2022
4	Senior Memorial Field fencing project	Install new fencing at widely used softball field	\$40,181.00	Estimated annual revenue for FY 2022
5	Phase I of II for Veterans Memorial Circle at Evergreen Cemetery	Install flags, lighting and related electrical service	\$48,385.00	Estimated annual revenue for FY 2022
		Total:	\$127,066.00	

East Harwich Methodist Church Cemetery Gravestone Project

ARTICLE 27: To see if the Town will vote to appropriate from Community Preservation Act Funds- estimated annual revenue for Fiscal Year 2022 \$112,200 to support the East Harwich Methodist Church Cemetery Gravestone Project. Any funds left unspent from this Article are to be returned to the Community Preservation Act Funds - Undesignated Fund Balance, and to act fully thereon. By request of the Community Preservation Committee and the Cemetery Commission. Estimated Cost: \$112,200.00.

Explanation: The article funds the cleaning, consolidation, repair and/or resetting of grave markers in the East Harwich Methodist Church Cemetery.

FINANCE COMMITTEE RECOMMENDS THIS ARTICLE BE ACCEPTED AND ADOPTED. VOTE: YES-#, NO-#

ROLL CALL VOTES:

Finance Committee:

To accept and adopt:

Yeas: # (number): [Members by Roll Call]

Nays: # (number): [Members by Roll Call]

Board of Selectmen:

To accept and adopt:

Yeas: # (number): [Members by Roll Call]

Nays: # (number): [Members by Roll Call]

Brooks Academy Structural Improvement Projects

ARTICLE 28: To see if the Town will vote to appropriate from Community Preservation Act Funds - \$485,734.55 from the Historic Reserve, \$664,265.45 from the estimated annual revenue for Fiscal Year 2022, for a total appropriation of \$1,150,000.000, to make structural improvements to Brooks Academy. Any funds left unspent from this Article are to be returned to the Community Preservation Act Funds-Historic Reserve and to act fully thereon. By request of the Community Preservation Committee and the Brooks Academy Museum Commission. Estimated Cost: \$1,150,000.00.

Explanation:

FINANCE COMMITTEE RECOMMENDS THIS ARTICLE BE ACCEPTED AND ADOPTED. VOTE: YES-#, NO-#

ROLL CALL VOTES:

Finance Committee:

To accept and adopt:

Yeas: # (number): [Members by Roll Call]

Nays: # (number): [Members by Roll Call]

Board of Selectmen:

To accept and adopt:

Yeas: # (number): [Members by Roll Call]

Nays: # (number): [Members by Roll Call]

Fund a Part-Time Housing Coordinator

ARTICLE 29: To see if the Town will vote to appropriate from Community Preservation Act Funds- \$50,000.00 from the estimated annual revenue for Fiscal Year 2022 to fund the Harwich Affordable Housing Trust Housing Coordinator. Any funds left unspent from this Article are to be returned to the Community Preservation Act Funds-Housing Reserve, and to act fully thereon. By request of the Community Preservation Committee and the Affordable Housing Trust. Estimated Cost: \$50,000.00.

Explanation: Annual request to fund a part-time housing coordinator to support the Affordable Housing Trust.

FINANCE COMMITTEE RECOMMENDS THIS ARTICLE BE ACCEPTED AND ADOPTED. VOTE: YES-#, NO-#

ROLL CALL VOTES:

Finance Committee:

To accept and adopt:

Yeas: # (number): [Members by Roll Call]

Nays: # (number): [Members by Roll Call]

Board of Selectmen:

To accept and adopt:

Yeas: # (number): [Members by Roll Call]

Nays: # (number): [Members by Roll Call]

Hinckleys Pond Watershed Preservation Project

ARTICLE 30: To see if the Town will vote to appropriate from Community Preservation Act Funds - \$360,000.00 from the Open Space Reserve to fund the acquisition of a parcel of land located on Headwaters Drive and identified as Assessor's Parcel 81-G1, and costs incidental or related thereto, and to authorize the Board of Selectmen to acquire said parcel for open space and passive recreation purposes by purchase, gift, and/or eminent domain on such terms and conditions as the Board of Selectmen deems in the best interests of the Town, and to grant a conservation restriction thereon to Harwich Conservation Trust and/or any other qualified entity pursuant to G.L. c. 184, §§31-33 and meeting the requirements of G.L. c. 44B, §12(a), with the care, custody and control of said parcel to be held by the Conservation Commission pursuant to the provisions of G.L. c. 40, §8C, Any funds left unspent from this Article are to be returned to the Community Preservation Act Funds-Open

Space Reserve, and to act fully thereon. By request of the Community Preservation Committee and the Real Estate & Open Space Committee. Estimated Cost: \$360,000.00.

Explanation: The goal of this article is to support a partnership between the Town, State, and nonprofit Harwich Conservation Trust (HCT) that will result in the preservation of approximately 31 acres in the Hinckleys Pond/Herring River Watershed to protect water quality, walking trails, land bordering the Cape Cod Rail Trail bike path, scenic views, and wildlife habitat. The following parcels owned by the Jenkins Nominee Trust (9 deeds) would be purchased by the Town, the Commonwealth of Massachusetts, and the Harwich Conservation Trust: Assessor Map 81, Lot G1: Assessor Map 81, Lot G2-1: Assessor Map 81, Lot G2-2: Assessor Map 81, Lot G2-3: Assessor Map 81, Lot G2-4-1: Assessor Map 81, Lot G2-4-2: Assessor Map 81, Lot G3: Assessor Map 81, Lot G3-1

FINANCE COMMITTEE RECOMMENDS THIS ARTICLE BE ACCEPTED AND ADOPTED. VOTE: YES-#, NO-#

ROLL CALL VOTES:

Finance Committee:

To accept and adopt:

Yeas: # (number): [Members by Roll Call]

Nays: # (number): [Members by Roll Call]

Board of Selectmen:

To accept and adopt:

Yeas: # (number): [Members by Roll Call]

Nays: # (number): [Members by Roll Call]

Harwich Natural Heritage Trail Project

ARTICLE 31: To see if the Town will vote to appropriate from Community Preservation Act Funds - \$150,000 from estimated annual revenue for Fiscal Year 2022 to fund the Natural Heritage Trail Project, including the creation of a wheelchair accessible trail loop off Bank Street for open space and recreational purposes, and further to authorize the Board of Selectmen to enter into a grant agreement with the Harwich Conservation Trust, and further to authorize the Board of Selectmen to acquire a permanent restriction on said land. Any funds left unspent from this Article are to be returned to the Community Preservation Act Funds-Undesignated Fund Balance, and to act fully thereon. By request of the Community Preservation Committee. Estimated Cost: \$150,000.00.

Explanation: The Harwich Natural Heritage Trail Project goal is to enhance the recreational and educational experience in Harwich by creating a wheelchair accessible trail loop off Bank Street at HCT's Robert F. Smith Cold Brook Preserve, which is also the site of a HCT/Town ecological restoration partnership. Harwich residents and visitors will be able to enjoy passive recreational opportunities (walking, birdwatching, dog walking, photography, and more) in a scenic and ecologically restored destination between Harwich Center and downtown Harwich Port.

FINANCE COMMITTEE RECOMMENDS THIS ARTICLE BE ACCEPTED AND ADOPTED. VOTE: YES-#, NO-#

ROLL CALL VOTES:

Finance Committee:

To accept and adopt:

Yeas: # (number): [Members by Roll Call]

Nays: # (number): [Members by Roll Call]

Board of Selectmen:

To accept and adopt:

Yeas: # (number): [Members by Roll Call]

Nays: # (number): [Members by Roll Call]

Brooks Park Lighting Project

ARTICLE 32: To see if the Town will vote to appropriate from Community Preservation Act Funds - \$125,000 from estimated annual revenue for Fiscal Year 2022 to fund the Brooks Park Lighting Project. Any funds left unspent from this Article are to be returned to the Community Preservation Act Funds-Undesignated Fund Balance, and to act fully thereon. By request of the Community Preservation Committee and the Recreation & Youth Commission. Estimated Cost: \$125,000.00.

Explanation:

FINANCE COMMITTEE RECOMMENDS THIS ARTICLE BE ACCEPTED AND ADOPTED. VOTE: YES-#, NO-#

ROLL CALL VOTES:

Finance Committee:

To accept and adopt:

Yeas: # (number): [Members by Roll Call]

Nays: # (number): [Members by Roll Call]

Board of Selectmen:

To accept and adopt:

Yeas: # (number): [Members by Roll Call]

Nays: # (number): [Members by Roll Call]

Sand Pond Revitalization Project

ARTICLE 33: To see if the Town will vote to appropriate from Community Preservation Act Funds - \$83,500.00 from estimated annual revenue for Fiscal Year 2022 to fund the rehabilitation and restoration of Sand Pond, which is a recreational facility owned by the

Town of Harwich. Any funds left unspent from this Article are to be returned to the Community Preservation Act Funds-Undesignated Fund Balance, and to act fully thereon. By request of the Community Preservation Committee and the Recreation & Youth Commission. Estimated Cost: \$83,500.00.

Explanation:

FINANCE COMMITTEE RECOMMENDS THIS ARTICLE BE ACCEPTED AND ADOPTED. VOTE: YES-#, NO-#

ROLL CALL VOTES:

Finance Committee:

To accept and adopt:

Yeas: # (number): [Members by Roll Call]

Nays: # (number): [Members by Roll Call]

Board of Selectmen:

To accept and adopt:

Yeas: # (number): [Members by Roll Call]

Nays: # (number): [Members by Roll Call]

Amend The Code of The Town Of Harwich Charter to Amend Chapter 9, Section 6

ARTICLE 34: To see if the Town will vote pursuant to M.G.L. c.43B, §10 to amend Chapter 9, Section 6 of the Town Charter, as set forth below, with strikethrough text to be deleted and bold, underlined text to be inserted:

Section 6. Capital Outlay Plan

9-6-1 The purpose of the ~~7~~ **5**-year capital outlay plan shall be to provide the town with a long-range forecast of the town's major capital improvement needs and to attempt to keep debt borrowing levels as even as possible from year to year.

9-6-2 A "capital outlay" shall mean the acquisition, construction or renovation of buildings, equipment or land having a total cost of \$50,000 **or more** during any budget year and planning funds for any such capital outlay.

9-6-3 The town administrator and the capital outlay committee shall submit a ~~7~~ **5**-year capital outlay plan to a joint public meeting of the board of selectmen and the finance committee during the month of December of each year.

9-6-4 The board of selectmen shall prepare articles to be included in the May annual town meeting warrant seeking adoption of the ~~7~~ **5**-year capital outlay plan and funding of the current year of the plan.

9-6-5 A simple majority vote of the town meeting shall be required to adopt the ~~7~~ 5-year capital outlay plan as submitted. Any amendment to a previously adopted Capital Plan shall require a two-thirds vote at the Annual Town Meeting.

9-6-6 If any part of the current year of the plan receives funding support at the annual town meeting, but fails at any necessary debt exclusion, capital exclusion or proposition 2 1/2 override ballot votes, the unsupported portion shall be returned to the ~~7~~ 5-year capital plan in year 1 of the next ~~7~~ 5-year plan, and to act fully thereon. By the Board of Selectmen.

Explanation: This article seeks to correct defects in Article 36 at the Annual Town Meeting in 2019. The statement under the Finance Committee's recommendation at that time indicated that the article was intended to modify the Capital Outlay Plan from seven (7) years to five (5) years. The article amends 9-6-2 by providing text to qualify that capital outlay items are \$50,000 or greater. These amendments will be subject to approval by the voters at the 2022 Annual Town Election if adopted at this town meeting.

FINANCE COMMITTEE RECOMMENDS THIS ARTICLE BE ACCEPTED AND ADOPTED. VOTE: YES-#, NO-#

ROLL CALL VOTES:

Finance Committee:

To accept and adopt:

Yeas: # (number): [Members by Roll Call]

Nays: # (number): [Members by Roll Call]

Board of Selectmen:

To accept and adopt:

Yeas: # (number): [Members by Roll Call]

Nays: # (number): [Members by Roll Call]

Amend Zoning Bylaw - §325-42 Design Requirements, Subsection L

ARTICLE 35: To see if the Town will vote to amend the Code of the Town of Harwich – Zoning Bylaw by amending §325-42.L by making the following changes (new text shown in **bold underline** and deleted language shown in strike-out):

Parking and loading zone setbacks for all uses except single-family, two-family and single-family with accessory apartment shall be as follows. For commercial structures, wheel stops for parking spaces perpendicular to or at an angle to a structure shall be located so as to provide a clear area of three feet between the end of a vehicle parked in the space and the nearest structure.

**Parking Setbacks¹
(feet)**

Zone	Street	Side Line	Rear
RR, RM, RL, RH-1, RH-2 and RH-3	20	10	10
CV, CH-1 and CH-2	20	10	10
IL	15	5	5
MRL and MRL-1	50	50	50
	<u>Note 2</u>	<u>Note 2</u>	<u>Note 2</u>

Notes:

¹ No parking area containing more than four spaces or loading area shall be located within a required front yard, except that those buildings utilizing the provisions of §325-51L (Village Commercial Overlay District) shall not locate any parking within the front yard.

²(a) On properties with existing structures, the setbacks for parking shall be established at the time of the site plan review.

(b) For vacant lands to be developed for any purpose (other than single-family, two-family and single-family with accessory apartment) the minimum setbacks for parking shall be 25 feet from the street and rear property line and 20 feet from the side property line.

And to act fully thereon. By request of the Planning Board

Explanation: These changes would allow for creativity and flexibility for parking within the MRL and MRL-1 zoning district, particularly for already improved properties.

FINANCE COMMITTEE RECOMMENDS THIS ARTICLE BE ACCEPTED AND ADOPTED. VOTE: YES-#, NO-#

ROLL CALL VOTES:

Finance Committee:

To accept and adopt:

Yeas: # (number): [Members by Roll Call]

Nays: # (number): [Members by Roll Call]

Board of Selectmen:

To accept and adopt:

Yeas: # (number): [Members by Roll Call]

Nays: # (number): [Members by Roll Call]

Amend Zoning Article XXIV By Adding A New Section - §325-160 Design Guidelines

Article 36: To see if the Town will vote to amend the Code of the Town of Harwich – Zoning Article XXIV West Harwich Special District by adding a new §325-160 as follows:

§325-160 Design Guidelines

For the purpose of this section the Harwich Planning Board, after a public hearing, shall adopt “*West Harwich Special District Site and Architectural Design Guidelines*” which shall constitute rules and regulations guiding historic structures and new construction within the WHSD. And to act fully thereon. By request of the Planning Board

***Explanation:** The new section 325-160 references design guidelines for the West Harwich Special District, which will be created and adopted by the Harwich Planning Board through a separate public hearing process. These guidelines will assist property owners and applicants with the development and redevelopment of properties within the West Harwich Special District (aka the West Harwich DCPC).*

FINANCE COMMITTEE RECOMMENDS THIS ARTICLE BE ACCEPTED AND ADOPTED. VOTE: YES-#, NO-#

ROLL CALL VOTES:

Finance Committee:

To accept and adopt:

Yeas: # (number): [Members by Roll Call]

Nays: # (number): [Members by Roll Call]

Board of Selectmen:

To accept and adopt:

Yeas: # (number): [Members by Roll Call]

Nays: # (number): [Members by Roll Call]

Amend General Bylaw Ch. 304 – Water Dependent Structures

Article 37: To see if the Town will vote to amend the Code of the Town of Harwich under the General Bylaw Chapter 304 Water Dependent Structures as follows (new text shown in **bold underline** and deleted language shown in strike-out):

Within §304-1. Purpose - add the phrase “**elevated walkway**” after “dock” in the first sentence.

Within §304-2 Definitions – add one new definition as follows:

CUMULATIVE IMPACT - The effect of a subject activity which, when considered in isolation, may or may not have a significant impact on environmental interests but when considered in relation to other past, present or anticipated future activities in a given area can be expected to be significant in the aggregate.

And further, amend the definitions of Mean High Water, Piling, and Water Dependent Structure as follows:

MEAN HIGH WATER - The elevation in feet above North American Vertical Datum of 1988 (NAVD 88) ~~National Geodetic Vertical Datum (NGVD)~~ established by the present arithmetic mean of the water heights observed at high tide over a specific nineteen-year Metonic cycle (the National Tidal Datum Epoch) as shown on the New England Coastline Tidal Flood Survey - Tidal Flood Profile No. 9 Barnstable to Chatham, MA by the New England Division, Corps of Engineers. Where salt marsh occurs, the mean high tide will be that point where *Spartina alterniflora* gives way to *Spartina patens*. Walkways over salt marshes that extend beyond this intersection will be regulated under the provisions of this bylaw.

PILING - A column constructed from any material used to support the deck or other structural member of a wharf, pier, elevated walkway, or dock or to serve as a mooring spar or dolphin for vessels or floats.

WATER-DEPENDENT STRUCTURE - Any structure or combination of structures built adjacent to or at an angle from the shore and extending seaward beyond the mean high-water mark so that people may access the water ~~vessels may lie alongside to receive and discharge passengers or cargo or for use as a promenade~~ and shall include structures commonly referred to as floats, docks, piers, elevated walkways, or wharves.

Within §304-4 Restricted Areas –amend as follows (new language is shown in **bold underline** and deleted text is shown in ~~strike-out~~):

No permit shall be issued for construction of a new, private, water-dependent structure in the **following** areas: ~~of~~

Round Cove ~~of~~ **in** Pleasant Bay. This area includes all contiguous parcels beginning with the northerly boundary of the property (Map and Parcel Number 115-S1-3) and extending southerly along the shore to the southerly boundary of the property (Map and Parcel Number 109-B1-5), and all shore front parcels between these two properties, including Round Cove. This prohibition does not apply to existing, licensed structures or to the maintenance of existing, licensed structures.

Both sides of the Herring River. This area includes all contiguous parcels beginning at the northerly boundary of Map 28 Parcel D1 on North Road near the pedestrian bridge over the river, and extending southerly down the river to the southern boundary of 1 Belmont Road, Map 1 Parcel C1, at the mouth of the river where it opens up to Nantucket Sound.

Within § 304-5 Application for a permit in section B1, change fourteen copies to twelve, and add the phrase “and narratives’ after “plans” in the first sentence.

Within § 304-8 Standards to be met, amend sections D, F, H, and J, and add a section K as follows (new language is shown in **bold underline** and deleted text is shown in ~~strike-out~~).

D. No structure (except floats) shall exceed four feet ~~of walkway~~ **in** width.

F. In order to protect the foreshore, all structures (except floats) shall be supported by pilings. Decks shall have a minimum $1\frac{1}{2}$ $\frac{3}{4}$ inch spacing between deck planks, **or may use grating instead with permission from the Commission**, and shall be at an elevation **height** equal to **1.5 times** the width of the deck above mean high water or, in areas of marsh, above the marsh vegetation **the salt marsh to the decking**, whichever is higher. **In areas where the structure is over a wetland resource area other than salt marsh, the height may be equal to 1.25 times the width of the deck.** Notwithstanding the foregoing, in all areas where the foreshore is passable on foot, a flight of stairs on either side of the deck shall be provided to allow persons to lawfully use the foreshore, **or be of a height that persons may pass underneath with.** A directional sign in compliance with the Zoning Bylaw, Chapter 325, Article VII, shall be placed indicating permission to cross the structure.

H. No structure shall be located within 50 feet of an existing eelgrass bed or within a shellfish area defined by the Town bylaws or Town Shellfish Warden, **unless expressly allowed by a variance from the Conservation Commission upon clear and convincing evidence provided by the applicant that the proposed project will not have an adverse impact to the wetland resource area(s) or its interest(s). An indication of** the presence or absence of shellfish at a proposed site ~~must~~ **may** be determined by a shellfish survey submitted by the applicant. **This shellfish survey shall conform to the sampling methods set forth in the Harwich Wetland Protection Regulations.** The survey shall include existing populations of all sizes of commercially important species of shellfish (clams, **oysters**, quahogs, scallops, and mussels) and shall also include other species of mollusks which may indicate the capacity of the area to support commercially important species. The survey shall also include a description of shell fragments, if feasible, and references, if available, to historical information regarding the presence or absence of shellfish species. Within the Pleasant Bay ACEC, relocation of shellfish encountered during construction of a project is not acceptable mitigation (except when the project is part of a Town- or state-sponsored shellfish relay program, and then only if it can be clearly shown that the productivity of that shellfish bed would not be diminished by its relocation).

~~J. In order to provide the underlying seabed full exposure to sunlight during six months of the year, all proposed structures shall be seasonal, with seven months' maximum use. Off-season storage plans shall be submitted for review and approval by the Conservation Commission.~~

J. Recreational water dependent structures are allowed to be used for six months out of the year (May-October). Floats are to be removed from the water by November 1 annually. Off-season storage of the floats shall be off site or outside of the 50' wetland buffer and not on any native plant species. Storage of the float on the marsh is strictly prohibited, and shall result in enforcement action from the commission.

K. There shall be a depth of at least three feet at mean low water on all sides of the float. No vessel shall be aground at mean low water.

Within §304-9 Denial of a Permit – amend as follows (new language is shown in **bold underline** and deleted text is shown in ~~strike-out~~):

The Commission may deny a permit in any case where a proposed **water dependent** structure or combination of structures, **does not meet the criteria set forth in this Bylaw.** otherwise complying herewith, would not extend to a point where at mean low water a water depth of at least ~~2 1/2~~ feet is maintained ~~no vessel shall be aground at mean low water.~~

And to act fully thereon. By request of the Conservation Commission

FINANCE COMMITTEE RECOMMENDS THIS ARTICLE BE ACCEPTED AND ADOPTED. VOTE: YES-#, NO-#

ROLL CALL VOTES:

Finance Committee:

To accept and adopt:

Yeas: # (number): [Members by Roll Call]

Nays: # (number): [Members by Roll Call]

Board of Selectmen:

To accept and adopt:

Yeas: # (number): [Members by Roll Call]

Nays: # (number): [Members by Roll Call]

Amend General Bylaw Ch. 310 – Wetlands Protection Bylaw

Article 38: To see if the Town will vote to amend the Code of the Town of Harwich under the General Bylaw Chapter 310 Wetlands Protection as follows:

Within §310-2. Definitions, Paragraph A, delete the last sentence under the definition of Agriculture and the definition of Aquaculture,

and further, add seven new definitions, in alphabetical order as follows:

BUFFER ZONE - The jurisdictional area extending 100 feet landward from a wetland resource area as defined in §310-3 herein. Land Subject to Coastal Storm Flowage and Riverfront Area do not have any buffer zones under this bylaw.

CUMULATIVE IMPACT - The effect of a subject activity which, when considered in isolation, may or may not have a significant impact on environmental interests but when considered in relation to other past, present or anticipated future activities in a given area can be expected to be significant in the aggregate.

MITIGATION - The means to offset any potential negative impacts a project may have on a wetland resource area(s) or buffer zone(s) thereto, and a means to improve the wetland resource area(s) and their interests on the site. There are various forms of mitigation the Commission may consider, including but not limited to on-site mitigation, off-site mitigation, and in-lieu fees on mitigation-constrained sites to improve specific other wetland resource areas in town.

MITIGATION-CONSTRAINED SITES - A project site that does not lend itself to the need for any on-site mitigation, but due to the proposed activity on the site, requires mitigation as per the Harwich Wetlands Protection Regulations.

SIXTY FOOT NO NEW STRUCTURE ZONE - The 60 foot no new structure zone is the upland area that extends from the landward edge of the wetland sixty feet inland as determined by a professional land survey and approved wetland delineation. When siting a new building or an addition within the 50-100-foot buffer zone, the structure shall be set back at least 60 feet from the resource area to allow for human and wildlife passage between the building and the 50-foot buffer, to reduce alteration to the 50-foot buffer, and to avoid the intrusion of lawn in the 50-foot buffer. Within the 50-60' buffer area, no new structure is permitted that would impede access so as to cause intrusion into the 50' No Disturb Zone.

SHELLFISH - Mollusks including by not limited to the following: clams, conchs, mussels, oysters, periwinkles, quahogs, razor clams, scallops, and sea clams; and crustaceans such as lobster or crab.

VARIANCE - An official dispensation from a rule or regulation. As it pertains to the Harwich Wetlands Bylaw and Regulations, a variance will only be allowed upon clear and convincing evidence by the applicant that a proposed activity will not have an adverse impact on any wetland resource area, buffer zone, or their interests.

and further, amend the definition of No-Disturb Zone as follows (new language is shown in **bold underline** and deleted text is shown in ~~strike-out~~):

NO-DISTURB ZONE - The land running 50 feet landward from **the landward limit of an abutting wetland resource area as determined by a professional land survey and approved wetland delineation.** No ~~substantial~~ activity, that will result in the building within or upon, filling, removing or altering of land, shall be permitted, with the following exceptions:

- (1) Maintenance **or reconstruction** of an existing permitted structure **within the same footprint.**
- (2) An activity that has been expressly allowed by a variance from the Conservation Commission.

Amend §310-3. Jurisdiction, paragraph A as follows (new language is shown in **bold underline** and deleted text is shown in ~~strike-out~~): :

Freshwater wetland resource areas. Marshes; wet meadows; bogs; swamps; vernal pools and vernal pool habitat; lands subject to flooding, both bordering and isolated; isolated wetlands greater than 3,000 square feet; banks; reservoirs; lakes; ponds greater than ~~3,000~~ **1,000** square feet; rivers, including the two-hundred-foot riverfront area; streams and creeks, including intermittent streams; and the lands underneath lakes, ponds, streams and creeks.

and further amend paragraph C as follows (new language is shown in bold underline)

Lands within 100 feet of any of the aforesaid resource areas, as set out in this section, except for the riverfront area, **land subject to coastal storm flowage** and **the landward limit of vernal pool habitat**.

And further, delete paragraph D in its entirety and replace it with the following:

D. Conservation variance provision. In rare and unusual circumstances the Commission, at its sole discretion, may grant a conservation variance from the requirements of this bylaw. Such a conservation variance shall be granted only in the following cases:

- (1) Where maximum feasible compliance is achieved; and
- (2) Where there are clear and compelling reasons of public safety and welfare; or
- (3) Where the proposed project will enhance the environmental values protected by the bylaw; or
- (4) Upon a clear and convincing showing of evidence by the applicant that the proposed work will not adversely affect the environmental values protected by the bylaw.

Within §310-4 Conditional Exceptions, paragraph B, add the words “active, lawful” in front of “cranberry bogs;”

And further, in paragraph C change allow 30 days instead of 21 days after the commencement of an emergency project for a permit application to be filed with the Conservation Commission;

And further, in paragraph D, add the phrase “this Bylaw and associated Wetland Protection Regulations” after “may grant a conservation variance from the requirements of” and omit the phrase “the fifty-foot no-disturb zone.”

Within §310-8 Permits and conditions, paragraph C, insert the word “provide” after the word “shall in the second sentence.

and further, add the following new paragraphs:

J. Pursuant to G.L. c. 44, § 53G, the Commission is authorized to require an applicant to pay a fee for the reasonable costs and expenses borne by the Commission for specific expert engineering and other consultant services deemed necessary by the Commission to come to a final decision on the application. This fee is called the consultant fee. The specific consultant services may include but are not limited to the resource area survey and delineation, analysis of resource area values, including wildlife habitat evaluations, hydrogeologic and drainage analysis and environmental or land use law.

K. The Commission may require the payment of the consultant fee at any point in its deliberations prior to a final decision. The applicant shall pay the fee to the Town to be put into a consultant services account of the Commission which may be drawn upon by the

Commission for specific consultant services approved by the Commission at one of its public meetings.

L. The exercise of discretion by the Commission in making its determination to require the payment of a fee shall be based upon its reasonable finding that additional information acquirable only through outside consultants would be necessary for the making of an objective decision.

M. The Commission shall return any unused portion of the consultant fee to the applicant unless the Commission decides at a public meeting that other action is necessary. Any applicant aggrieved may appeal according to the provisions of the Massachusetts General Laws. And to act fully thereon. By request of the Conservation Commission

FINANCE COMMITTEE RECOMMENDS THIS ARTICLE BE ACCEPTED AND ADOPTED. VOTE: YES-#, NO-#

ROLL CALL VOTES:

Finance Committee:

To accept and adopt:

Yeas: # (number): [Members by Roll Call]

Nays: # (number): [Members by Roll Call]

Board of Selectmen:

To accept and adopt:

Yeas: # (number): [Members by Roll Call]

Nays: # (number): [Members by Roll Call]

Amend General Bylaw Ch. 131 – Historic Preservation

Article 39: To see if the Town will vote to **[PLACEHOLDER FOR HDHC Demolition Delay Bylaw]**

Explanation: Provides consistency of Demolition Delay document across Cape towns. Most towns use this format as base document. Value to town citizens but also to prospective purchasers, realtors, lawyers and builders a working across town boundaries.

FINANCE COMMITTEE RECOMMENDS THIS ARTICLE BE ACCEPTED AND ADOPTED. VOTE: YES-#, NO-#

ROLL CALL VOTES:

Finance Committee:

To accept and adopt:

Yeas: # (number): [Members by Roll Call]

Nays: # (number): [Members by Roll Call]

Board of Selectmen:

To accept and adopt:

Yeas: # (number): [Members by Roll Call]

Nays: # (number): [Members by Roll Call]

Approval of DHY Clean Waters Community Partnership Agreement

Article 40: To see if the Town will vote pursuant to Chapter 88 of the Acts of 2019 to approve an Agreement among the Towns of Dennis, Harwich, and Yarmouth for the establishment of a three town wastewater district to be known as the DHY Clean Waters Community Partnership, a copy of said agreement is on file in the office of the Town Clerk; it being understood that by approving said agreement the Town will be responsible for its apportioned share of the costs for permitting, design, and construction of a wastewater treatment facility, effluent recharge facilities and related infrastructure as well as the Town's apportioned share of the annual operation and maintenance cost of said facilities, or to act fully thereon. By request of the Board of Selectmen.

Explanation: [PLACEHOLDER ARTICLE PENDING FURTHER DISCUSSION BY BOS]

FINANCE COMMITTEE RECOMMENDS THIS ARTICLE BE ACCEPTED AND ADOPTED. VOTE: YES-#, NO-#

ROLL CALL VOTES:

Finance Committee:

To accept and adopt:

Yeas: # (number): [Members by Roll Call]

Nays: # (number): [Members by Roll Call]

Board of Selectmen:

To accept and adopt:

Yeas: # (number): [Members by Roll Call]

Nays: # (number): [Members by Roll Call]

Authorize the sale of 5 Bells Neck Road

Article 41: To see if the Town will vote to transfer the care, custody, management and control of the Town-owned property with the building thereon located at 5 Bells Neck Road from the Board of Selectmen for the purpose of leasing to a nonprofit for affordable and market-rate housing and for arts, cultural, educational or other purposes to the Board of Selectmen for the purpose of conveyance, and to authorize the Board of Selectmen to convey said property on such terms and conditions and for such consideration and purposes as the Board deems in the best interest of the Town, which may include reserving or obtaining a historic preservation restriction on said property, and to hereby rescind the terms, conditions and restrictions placed on the disposition of said property by the votes taken under Article 60 of the 2006 Annual Town Meeting and Article 12 of the Special Town Meeting of May, or to act fully thereon. By request of the Board of Selectmen.

Explanation: Previous efforts to lease this property were not successful. This article would allow the Board of Selectmen to seek Requests for Proposals (RFP) for the outright sale of this property in light of recent interest from several local groups to acquire the property.

Requires a two-thirds vote for adoption

FINANCE COMMITTEE RECOMMENDS THIS ARTICLE BE ACCEPTED AND ADOPTED. VOTE: YES-#, NO-#

ROLL CALL VOTES:

Finance Committee:

To accept and adopt:

Yeas: # (number): [Members by Roll Call]

Nays: # (number): [Members by Roll Call]

Board of Selectmen:

To accept and adopt:

Yeas: # (number): [Members by Roll Call]

Nays: # (number): [Members by Roll Call]

Amend the Code of Harwich General Bylaws – Chapter 8 Departmental Revolving Funds
§ 8-1. Funds Established

ARTICLE 42: To see if the Town will vote to amend the Departmental Revolving Funds Bylaw, Section 8-1 of the Town Code, (the language to be added is shown in underlined text), or to act fully thereon. By request of the Conservation Commission.

Revolving Fund	Authorize to Spend Fund	Revenue Source	Use of Fund
Wetlands	Conservation Commission	Notice of Intent Filing Fees; <u>as well as in-lieu fees generated as a result of an approval of a Notice of Intent</u>	Consultants and wetland and buffer zone management and restoration projects

FINANCE COMMITTEE RECOMMENDS THIS ARTICLE BE ACCEPTED AND ADOPTED. VOTE: YES-#, NO-#

ROLL CALL VOTES:

Finance Committee:

To accept and adopt:

Yeas: # (number): [Members by Roll Call]

Nays: # (number): [Members by Roll Call]

Board of Selectmen:

To accept and adopt:

Yeas: # (number): [Members by Roll Call]

Nays: # (number): [Members by Roll Call]

Annual Departmental Revolving Funds Authorization

ARTICLE 43: To see if the Town will vote to set spending limits for various revolving funds that have been authorized pursuant to Section 8.1 of the Town Code: and to act fully thereon. By request of the Finance Director.

<u>Revolving Fund</u>	<u>FY 2022 Spending Limit</u>	<u>Disposition of FY21 Fund balance</u>
Golf Pro Shop and Restaurant Lease Revenue	\$250,000	Available for expenditure
Golf Infrastructure fund	\$140,000	Available for expenditure
Council on Aging	\$125,000	Available for expenditure
Cemetery	\$100,000	Available for expenditure
Community Center	\$100,000	Available for expenditure
Recreation	\$175,000	Available for expenditure
Albro House	\$10,000	Available for expenditure
ADA	\$2,500	Available for expenditure
Wetlands	\$6,000	Available for expenditure
Middle School Cultural Center	\$225,000	Available for expenditure
Sidewalks	\$50,000	Available for expenditure
Tax Title Collection	\$36,000	Available for expenditure

Explanation:

FINANCE COMMITTEE RECOMMENDS THIS ARTICLE BE ACCEPTED AND ADOPTED. VOTE: YES-#, NO-#

ROLL CALL VOTES:

Finance Committee:

To accept and adopt:

Yeas: # (number): [Members by Roll Call]

Nays: # (number): [Members by Roll Call]

Board of Selectmen:

To accept and adopt:

Yeas: # (number): [Members by Roll Call]

Nays: # (number): [Members by Roll Call]

Stabilization Fund

ARTICLE 44: To see if the Town will vote to raise and appropriate or transfer from available funds a sufficient sum of money to be added to the Stabilization Fund, and to act fully thereon. By the request of the Board of Selectmen. Estimated cost: \$###,###.

FINANCE COMMITTEE RECOMMENDS THIS ARTICLE BE ACCEPTED AND ADOPTED. VOTE: YES-#, NO-#

ROLL CALL VOTES:

Finance Committee:

To accept and adopt:

Yeas: # (number): [Members by Roll Call]

Nays: # (number): [Members by Roll Call]

Board of Selectmen:

To accept and adopt:

Yeas: # (number): [Members by Roll Call]

Nays: # (number): [Members by Roll Call]

OPEB Trust Fund

ARTICLE 45: To see if the Town will vote to raise and appropriate or transfer from available funds a sufficient sum of money to be added to the OPEB Trust Fund, and to act fully thereon. By the request of the Board of Selectmen. Estimated cost: \$###,###.

Explanation:

FINANCE COMMITTEE RECOMMENDS THIS ARTICLE BE ACCEPTED AND ADOPTED. VOTE: YES-#, NO-#

ROLL CALL VOTES:

Finance Committee:

To accept and adopt:

Yeas: # (number): [Members by Roll Call]

Nays: # (number): [Members by Roll Call]

Board of Selectmen:

To accept and adopt:

Yeas: # (number): [Members by Roll Call]

Nays: # (number): [Members by Roll Call]

Fund Prior Year's Unpaid Bills

ARTICLE 46: To see if the Town will vote to raise and appropriate or transfer from available funds a sufficient sum of money to pay unpaid bills of prior years as provided for in M.G.L.

Ch. 44, Section 64, and to act fully thereon. By request of the Finance Director. Estimated cost: \$#

Explanation:

FINANCE COMMITTEE RECOMMENDS THIS ARTICLE BE ACCEPTED AND ADOPTED. VOTE: YES-#, NO-#

ROLL CALL VOTES:

Finance Committee:

To accept and adopt:

Yeas: # (number): [Members by Roll Call]

Nays: # (number): [Members by Roll Call]

Board of Selectmen:

To accept and adopt:

Yeas: # (number): [Members by Roll Call]

Nays: # (number): [Members by Roll Call]

Promote the Town Of Harwich

ARTICLE 47: To see if the Town will vote to raise and appropriate and/or transfer from available funds a sufficient sum of money for the Harwich Chamber of Commerce to promote the Town and its businesses and cultural endeavors to advance economic development initiatives for and with the Town of Harwich. Said monies to be used to manage and fulfill year-round visitor/resident/business information services, to promote and market the Town, to generate and initiate materials and activities that encourage the establishment, growth and sustainability of businesses in Harwich, and to implement economic development objectives and activities in partnership with the Town, and to act fully thereon. By request of the Board of Selectmen. Estimated cost: \$30,000

Explanation: This is a customary article whereby the Town supports the efforts of the Harwich Chamber of Commerce in promoting the town widely and throughout the year.

FINANCE COMMITTEE RECOMMENDS THIS ARTICLE BE ACCEPTED AND ADOPTED. VOTE: YES-#, NO-#

ROLL CALL VOTES:

Finance Committee:

To accept and adopt:

Yeas: # (number): [Members by Roll Call]

Nays: # (number): [Members by Roll Call]

Board of Selectmen:

To accept and adopt:

Yeas: # (number): [Members by Roll Call]
Nays: # (number): [Members by Roll Call]

Defray the Expenses of The Chase Library and Harwich Port Library

ARTICLE 48: To see if the Town will vote to raise and appropriate and/or transfer from available funds the sum of \$20,000 to help defray the expenses of the Chase Library and the Harwich Port Library; said funds to be expended under the direction of the Chase Library and Harwich Port Library Trustees, and to act fully thereon. By request of the Board of Selectmen. Estimated cost: \$20,000

Explanation:

FINANCE COMMITTEE RECOMMENDS THIS ARTICLE BE ACCEPTED AND ADOPTED. VOTE: YES-#, NO-#

ROLL CALL VOTES:

Finance Committee:

To accept and adopt:

Yeas: # (number): [Members by Roll Call]

Nays: # (number): [Members by Roll Call]

Board of Selectmen:

To accept and adopt:

Yeas: # (number): [Members by Roll Call]

Nays: # (number): [Members by Roll Call]

Supplement Annual Allocation of Mass Cultural Council For
Local Cultural Council Grants

ARTICLE 49: To see if the Town will vote to raise and appropriate, transfer from available funds and/or borrow a sufficient sum of money to supplement the Massachusetts Cultural Council annual allocation for community grant awards to artists, performers, and interpretive scientists who bring events and programs to local venues which enhance the cultural experience of Harwich citizens of all ages, and to act fully thereon. By request of the Board of Selectmen and the Harwich Cultural Council. Estimated Cost: \$3,600.

Explanation:

FINANCE COMMITTEE RECOMMENDS THIS ARTICLE BE ACCEPTED AND ADOPTED. VOTE: YES-#, NO-#

ROLL CALL VOTES:

Finance Committee:

To accept and adopt:

Yeas: # (number): [Members by Roll Call]
Nays: # (number): [Members by Roll Call]

Board of Selectmen:

To accept and adopt:

Yeas: # (number): [Members by Roll Call]

Nays: # (number): [Members by Roll Call]

Herring Fisheries

ARTICLE 50: To see what action the Town will take in regard to the Herring Fisheries and to act fully thereon. Customary Article.

FINANCE COMMITTEE RECOMMENDS THIS ARTICLE BE ACCEPTED AND ADOPTED. VOTE: YES-#, NO-#

ROLL CALL VOTES:

Finance Committee:

To accept and adopt:

Yeas: # (number): [Members by Roll Call]

Nays: # (number): [Members by Roll Call]

Board of Selectmen:

To accept and adopt:

Yeas: # (number): [Members by Roll Call]

Nays: # (number): [Members by Roll Call]

Hereof fail not and make return of this warrant with your doings thereon at the time and place of said voting.

Given under our hands this 29th day of March, 2021.

Larry G. Ballantine, Chair

Stephen P. Ford, Vice Chair

Michael D. MacAskill, Clerk

Donald F. Howell

Edward J. McManus

Board of Selectmen
Town of Harwich

A true copy Attest:

Constable

**COMMONWEALTH OF MASSACHUSETTS
TOWN OF HARWICH
ANNUAL ELECTION BALLOT
MAY 21, 2019**

BARNSTABLE, ss:

To either of the Constables of the Town of Harwich in said County,

Greetings:

In the name of the Commonwealth of Massachusetts you are hereby directed to notify and warn the inhabitants of said Town qualified to vote in elections and Town affairs to meet in the Community Center Gymnasium, 100 Oak Street, in said Town on Tuesday, May 21, 2019, then and there to act on the following ballot:

POLLS WILL BE OPEN AT 7:00 A.M. and CLOSE AT 8:00 P.M.

To choose on one (1) ballot the following Town Officers and Committees: two (2) Selectmen for three (3) years; one (1) Town Clerk for three (3) years; one (1) Monomoy Regional School Committee Member for three (3) years; one (1) Monomoy Regional School Committee Member to fill a 1-year unexpired term; two (2) Library Trustees for three (3) years; one (1) Water Commissioner for three (3) years; one (1) Housing Authority member to fill a 2-year unexpired term

BALLOT QUESTIONS

1. Shall the Town of Harwich be allowed to exempt from the provisions of Proposition 2 1/2, so called, the amounts required to pay for the bond issued in order to fund the Reconstruction of Lower County Road including all costs incidental and related thereto, as requested in the Capital Plan for FY20?

YES _____ NO _____

2. Shall the Town of Harwich be allowed to exempt from the provisions of Proposition 2 1/2, so called, the amounts required to pay for the bond issued in order to fund the Road Maintenance Program, including, but not limited to Lower County Road and other roads on the Program, and all costs incidental and related thereto, as requested in the Capital Plan for FY20?

YES _____ NO _____

Hereof fail not and make return of this warrant with your doings thereon at the time and place of said voting.

Given under our hands this 29th day of March, 2021.

Larry G. Ballantine, Chair

Stephen P. Ford, Vice Chair

Michael D. MacAskill, Clerk

Donald F. Howell

Edward J. McManus

Board of Selectmen
Town of Harwich

A true copy Attest:

Constable

NOTES



TOWN OF HARWICH

FINANCE DEPARTMENT

732 MAIN STREET, HARWICH, MA 02645

TEL: 508-430-7518 FAX: 508-430-7504

Carol Coppola, CPA, CFE
Finance Director

Wendy A. Tulloch
Assistant Town Accountant

March 22, 2021

To: Joseph F. Powers

From: Carol Coppola

RE: Proposed Operating Budget

Please find enclosed the proposed changes to the March 4, 2021 version of the operating budget. A synopsis of the additions(reductions) includes the following changes:

BOS Budget Additions(Reductions) - 3/20/21		
Department	Amount	Description
Police	131,897	S& W - Fill 2 vacant Officer positions
Police	20,700	Expenses - Fill 2 vacant Officer positions
Youth	950	S&W - Longevity
Cemetery	(610)	Expenses - reduce travel
Monomoy Regional SD	(306,759)	MRSD - Budget reduction
County Assessment	7,970	6.1% increase received 3/19/21
Cape Cod Commission Assess	7,136	5.5% increase received 3/19/21
	(138,716)	

The new version of the operating budget for your review and presentation to the Board of Selectmen is dated March 22, 2021 time stamped at 9:03 am.

Town Administrator's Proposed Budget

Town of Harwich BUDGET 2022

Line #		Budget	Budget	
	SOURCES OF FUNDS	FY 2021	FY 2022	%
1	Tax Levy Limit (R/E & PP)	53,357,522	55,655,847	4.3%
2	Local Receipts	11,986,520	12,680,198	5.8%
3	<u>State Aid</u>			
4	Cherry Sheet	664,352	667,067	0.4%
5	Overlay Surplus	200,000	200,000	0.0%
6	<u>Transfers:</u>			
7	Total Transfers In from Other Sources:	2,713,239	2,184,137	-19.5%
8	TOTAL SOURCES	68,921,633	71,387,250	3.6%
9	USES OF FUNDS			
10	<u>Charges:</u>			
11	State-Cherry Sheet Charges (ccc & BC Tax)	764,539	786,800	2.9%
12	Overlay (Abatements- Taxes)	400,000	450,000	12.5%
13	<u>TOTAL CHARGES</u>	<u>1,123,358</u>	<u>1,236,800</u>	<u>10.1%</u>
14	<u>NET AVAILABLE Sources</u>	<u>67,798,275</u>	<u>70,150,450</u>	<u>3.5%</u>
15	Town Operating Budget	25,739,671	26,048,163	1.2%
16	<u>Semi-Fixed Cost</u>			
17	Barnstable County Retirement	3,144,894	3,242,673	3.1%
18	Debt Service	4,617,408	5,178,305	12.1%
19	Health Insurance	4,833,551	4,938,071	2.2%
20	OPEB	-	250,000	100.0%
21	Property & Liab. Insurance	874,470	897,726	2.7%
23	Unemployment	20,000	20,000	0.0%
24	Total Fixed Cost	13,490,322	14,526,775	7.7%
25	Cape Cod Tech HS	1,737,789	1,536,309	-11.6%
26	Monomoy Regional School District	26,820,046	27,361,048	2.0%
27	TOTAL USES	68,911,186	70,709,096	2.6%
29	NET SOURCES & USES	\$ 10,447	\$ 678,154	

**BUDGET
FY 2022 REVENUES**

	Actual FY2018	Actual FY2019	Actual FY2020	Budget FY2021	TA Proposed FY2022	% Change
Real Estate & Personal Property Taxes	\$46,774,148	\$50,127,321	\$51,445,928	\$53,299,729	\$55,655,847	4.4%
Local Receipts:						
Excise Tax	2,372,767	2,407,537	2,294,565	1,925,000	2,025,000	5.2%
Hotel/Motel & Meals	1,098,022	1,124,753	1,350,894	671,000	915,000	36.4%
Ambulance	1,452,109	1,664,188	1,601,026	1,600,000	1,600,000	0.0%
Waste Disposal	3,110,693	3,372,701	3,209,426	3,002,500	3,102,500	3.3%
Beach, Recreation & Youth	413,637	435,548	425,634	330,000	362,500	9.8%
Harbors & Landings	929,773	806,754	1,173,879	1,024,500	1,059,500	3.4%
Golf Operations	1,856,221	1,895,899	1,518,934	1,585,000	1,800,000	13.6%
Other Local Receipts	2,231,851	3,016,935	2,618,408	1,848,520	1,815,698	-1.8%
Total Local Receipts	13,465,072	14,724,316	14,192,766	11,986,520	12,680,198	5.8%
State Aid:						
Cherry Sheet	705,430	676,162	1,792,161	664,352	667,067	0.4%
Other:						
Free Cash	305,244	378,038	639,034	353,943	833,591	135.5%
Stabilization Fund				574,171	-	0.0%
Overlay Surplus	100,000	100,000	200,000	200,000	200,000	0.0%
Harbor Capital Improvement - Wychmere	110,930	62,808	72,227	0	0	0.0%
Cable Fund (Comcast)	143,417	156,450	144,398	210,107	210,100	0.0%
Septic Loan	17,358	17,358	13,574	17,171	6,121	-64.4%
Water Enterprise Indirect Costs	650,178	732,843	720,295	730,290	727,304	-0.4%
Sewer Enterprise Indirect Costs					31,446	0.0%
FEMA	13,508	13,608	13,815	13,855	13,855	0.0%
Road Betterments	49,194	58,277	56,973	51,100	55,166	8.0%
Allan Harbor Betterments	185,550	182,250	29,325	98,508	0	0.0%
Golf Infrastructure Revitalization Fund		139,000	249,000	108,200	104,950	-3.0%
Golf Improvement Fund				100,000	0	0.0%
SAQ Mooring		101,188	136,888	50,000	0	0.0%
SAQ Waterways		136,888	101,188	50,000	0	0.0%
CPA Funds (Land Bank)	608,950	588,750	553,700	341,750	233,050	-31.8%
Dog License Fund				2,144	0	0.0%
Town Clerk State Aid		15,585		12,000	0	0.0%
Total Revenue	\$63,128,979	\$68,210,840	\$70,361,273	\$68,863,840	\$71,418,696	3.7%

TOWN OF HARWICH

Local Receipts

Local Receipts General Fund	Actual FY2018	Actual FY2019	Actual FY2020	Budget FY2021	Budget FY2022	2020 vs 2022 Variance
010004 432029 PRIOR YEAR RECOVERY	-	-	9,252	-	-	9,252
010004 458902 FEMA SNOW REIMBURSEMENT	-	-	46,865	-	-	46,865
010004 481005 CC REG TECH FEE/(RES OFFICER)	20,000	20,000	20,000	20,000	20,000	-
010004 484099 GEN FUND MISC REVENUE	(3,912)	156,569	180,768	82,760	83,538	97,230
TOTAL GENERAL FUND - MISC REVENUE	16,088	176,569	256,886	102,760	103,538	153,348
011224 SELECTMEN - REV						

011224-432003 PHOTOCOPIES	-	5,000	29	-	-	29
011224-436008 OLD REC BLDG/JR THEATER LEASE	11,388	4,015	4,862	5,000	5,000	(138)
011224 436005 FRANCISE FEES	39,614	82,154	-	-	-	-
011224 441000 LIQUOR LICENSES	69,616	73,178	67,214	65,000	65,000	2,214
011224 442001 HOTEL, MOTEL, INN	785	750	800	700	700	100
011224 442004 JUNK COLLECTOR, DEALER	140	105	35	100	100	(65)
011224 442005 USED CAR DEALER	2,200	2,100	900	1,000	1,000	(100)
011224 442006 AMUSEMENT DEVICE LICENSE	100	-	-	-	-	-
011224 442009 ENTERTAINMENT LICENSE	3,990	3,775	3,535	3,500	3,500	35
011224 442012 COMMON VICTUALLER LICENSE	2,250	2,000	2,150	2,000	2,000	150
011224 445016 VEHICLE REPAIRMAN	-	-	1,100	-	-	1,100
011224 45005 MISCELLANEOUS LIC/PERMITS	60	60	60	60	60	-
011224 469900 OTHER STATE REVENUE	-	-	-	-	-	-
011224 484012 INSURANCE RECOVERY	-	-	74,758	-	-	74,758
TOTAL SELECTMEN - REV	130,143	173,137	155,443	77,360	77,360	78,083

011414 432003 PHOTOCOPIES	856	1,007	794	850	850	(57)
011414-432045 ABUTTERS FEES	9,262	11,284	10,938	11,000	11,000	(62)
TOTAL ASSESSORS - REV	10,118	12,291	11,732	11,850	11,850	(119)
011454 TREASURER - REV						

011454 432003 PHOTOCOPIES	26	-	-	-	-	-
011454 432007 BOUNCED CHECK FEE	750	525	725	500	500	225
011454 482001 INVESTMENT REVENUE	157,972	281,825	213,117	100,000	100,000	113,117
011454 484099 MISCELLANEOUS REVENUE	-	14,737	2,696	-	-	2,696
TOTAL TREASURER - REV	158,748	297,088	216,537	100,500	100,500	116,037
011464 COLLECTOR REV						

011464-414200 TAX TITLE	254,864	351,715	235,130	-	-	235,130
011464-414400 TAX DEFERRED REDEEMED	-	6,207	11	-	-	11
011464 417001 PEN & INT REAL ESTATE TAXES	106,388	117,964	94,988	100,000	100,000	(5,012)
011464 417002 PEN & INT PERS PROP TAXES	10,724	12,495	8,353	8,000	8,000	353
011464 417003 PEN & INT MV EXCISE TAXES	107,332	101,383	73,664	75,000	75,000	(1,336)
011464 417004 PEN & INT BOAT EXCISE TAXES	2,428	4,535	2,619	2,000	2,000	619
011464 417005 PEN & INT TAX TITLE	152,658	237,586	109,095	100,000	100,000	9,095
011464 417006 PEN & INT DEFERRED TAXES	1,176	4,373	57	-	-	57
011464 417009 PENALTY & INTEREST LAND BANK	-	-	-	-	-	-
011464 417010 PEN & INT SEPTIC BETTERMENT	1,036	-	-	-	-	-
011464 417013 INTEREST CPC	-	-	-	-	-	-
011464 418001 IN LIEU OF TAXES LOCAL	58,616	61,960	62,471	55,000	55,000	7,471
011464 432008 MARKING FEES	10,680	10,320	8,160	10,000	10,000	(1,840)
011464 432009 MUNICIPAL LIEN CERTIFICATES	18,375	18,425	26,200	18,000	18,000	8,200
011464 484001 MISC	-	(20)	1	-	-	1
TOTAL COLLECTOR - REV	724,276	926,942	620,749	368,000	368,000	252,749
011614 TOWN CLERK - REV						

011614 432003 PHOTOCOPIES	1,115	454	477	500	500	(23)

TOWN OF HARWICH

Local Receipts

Local Receipts General Fund	Actual FY2018	Actual FY2019	Actual FY2020	Budget FY2021	Budget FY2022	2020 vs 2022 Variance
011614 432011 DOG LICENCES	14,289	13,530	12,035	12,000	12,000	35
011614 432039 UTILITY POLES	40	320	-	100	100	(100)
011614 442017 BIRTH, MARRIAGE, DEATH CERT	16,240	21,140	17,640	16,000	16,000	1,640
011614 442018 BUSINESS CERTIFICATE	3,800	4,920	3,450	3,000	3,000	450
011614 442020 MEDICAL CERTIFICATES		-				-
011614 445002 RAFFLE PERMIT	120	60	40	50	50	(10)
011614 445007 GASOLINE STORAGE	375	350	250	300	300	(50)
011614 445015 BURIAL	1,120	1,530	1,370	1,000	1,000	370
011614 468500 INCREASE POLLING HOURS						-
011614 477000 NON CRIMINAL FINES FIRE	300	-	-	-	-	-
011614 477001 NON CRIMINAL FINES POLICE	125	100	325	-	-	325
011614 477002 NON CRIMINAL FINES HEALTH	-	25	2,150	-	-	2,150
011614 477006 NON CRIMINAL FINES HARBOR	500	50	100	-	-	100
011614 477007 NON CRIMINAL FINES CONSERVAT	1,500	2,100	11,400	1,500	1,500	9,900
011614 484099 TOWN CLERK MISC		62	900			900
TOTAL TOWN CLERK - REV	39,524	44,641	50,137	34,450	34,450	15,687
011714 CONSERVATION - REV						-
011714 432038 GARDEN PLOTS	2,983	3,140	3,280	2,900	2,900	380
011714 436003 BOG LEASE	4,780	5,211	3,804	4,000	4,000	(196)
011714 437001 HEARINGS	10,661	10,333	9,120	10,000	7,500	1,620
011714 484099 COMSERV MISC REVENUE	5,420	3,845	4,050	3,500	3,500	550
TOTAL CONSERVATION - REV	23,844	22,529	20,254	20,400	17,900	2,354
011744 TOWN PLANNER - REV						-
011744 432003 PHOTOCOPIES	20					-
011744 432040 PLANNING LOCAL FILING FE	9,458	6,100	5,990	6,000	6,000	(10)
011744 437001 HEARINGS	16,786	36,037	37,785	25,000	25,000	12,785
011744 445005 MISC LICENSES/PERMITS	265	265	265	-	-	265
TOTAL TOWN PLANNER - REV	26,529	42,402	44,040	31,000	31,000	13,040
011764 BOARD OF APPEALS - REV						-
011764 437001 HEARINGS	10,395	15,120	12,600	10,000	10,000	2,600
TOTAL BOARD OF APPEALS - REV	10,395	15,120	12,600	10,000	10,000	2,600
011994-421000 CVEC ELECTRIC FEES	270,608	272,162	288,800	275,000	275,000	13,800
012104 POLICE - REV						-
012104 432015 POLICE ADMINISTRATION FEES	59,684	57,201	45,625	45,000	45,000	625
012104 432016 POLICE INSURANCE CO FEES	-	-	-	-	-	-
012104 432017 USE OF CRUISER POLICE	10,370	6,570	13,240	6,500	6,500	6,740
012104 445003 GUN PERMITS	6,525	5,525	6,400	5,400	5,400	1,000
012104 468000 REG OF MV FINES	6,589	8,714	4,899	4,500	4,500	399
012104 469501 COURT FINES	825	968	1,215	800	800	415
012104 477004 PARKING VIOLATIONS	-	375	665	-	-	665
012104 477005 RESTITUTION		-	-	-	-	-
TOTAL POLICE - REV	83,993	79,353	72,044	62,200	62,200	9,844
012204 FIRE - REV						-
012204 432003 PHOTOCOPIES	100	230	125	-	-	125
012204 432018 FIRE/OIL BURNER INSPECTIONS	37,240	39,820	39,130	35,000	35,000	4,130
12204 4445006 BURN PERMITS	5,040	4,750	2,349	3,000	3,000	(651)
012204 445005 MISCELLANEOUS LICENSES/PERMITS	3,770	2,860	3,270	2,500	2,500	770
012204 445007 GASOLINE STORAGE	310	1,120	225	500	500	(275)
012204 469900 OTHER STATE REVENUE		63,565	6,800			6,800
012204 484099 MISCELLANEOUS REVENUE	2,875	2,925	2,275	-	-	2,275
TOTAL FIRE - REV	49,335	115,270	54,174	41,000	41,000	13,174

TOWN OF HARWICH

Local Receipts

Local Receipts General Fund	Actual FY2018	Actual FY2019	Actual FY2020	Budget FY2021	Budget FY2022	2020 vs 2022 Variance
012314 AMBULANCE - REV						-
-----						-
012314 437000 AMBULANCE FEES	1,452,109	1,664,188	1,601,026	1,600,000	1,600,000	1,026
TOTAL AMBULANCE - REV	1,452,109	1,664,188	1,601,026	1,600,000	1,600,000	1,026
012414 BUILDING - REV						-
-----						-
012414 432003 PHOTOCOPIES	1,649	1,679	1,123	1,600	1,600	(477)
012414 432019 BUILDING INSPECTION	3,966	6,210	171	1,000	1,000	(829)
012414 432048 BLDG. APPLICATION FEES	-	-	-	-	-	-
012414 455008 BUILDING PERMITS	278,699	394,330	371,296	350,000	350,000	21,296
012414 455009 SIGN PERMITS	2,695	3,125	2,025	2,500	2,500	(475)
012414 455010 DEMO PERMITS	-	-	-	-	-	-
012414 455011 RENTAL DENSITY PERMIT	1,100	2,900	1,750	1,000	1,000	750
012414 455012 HVAC SHEET METAL	-	-	41,110	-	-	41,110
012414 477000 NON CRIMINAL FINE	-	-	340	-	-	340
012414 494099 MISC REVENUE + Trenching	3,565	4,445	-	-	-	-
TOTAL BUILDING - REV	291,674	412,689	417,815	356,100	356,100	61,715
012424 GAS INSPECTION - REV						-
-----						-
012424 432020 GAS INPECTION &Trench Permits	47,545	53,595	57,550	50,000	50,000	7,550
TOTAL GAS INSPECTION - REV	47,545	53,595	57,550	50,000	50,000	7,550
012434 PLUMBING						-
-----						-
012434 432021 PLUMBING INSPECTION	49,765	61,040	58,945	55,000	55,000	3,945
TOTAL PLUMBING	49,765	61,040	58,945	55,000	55,000	3,945
012454 ELECTRICAL REVENUE						-
-----						-
012454 432023 ELECTRICAL INSPECTION	75,745	86,455	77,471	75,000	75,000	2,471
TOTAL ELECTRICAL REVENUE	75,745	86,455	77,471	75,000	75,000	2,471
012914 468600 EMERGENCY MGMT GRANT						-
012964 445001 SHELLFISH	9,645	9,363	9,466	9,000	9,000	466
014394 WASTE DISPOSAL REVENUE						-
-----						-
014394 424701 DISPOSAL AREA STICKERS	894,280	896,360	886,605	900,000	900,000	(13,396)
014394 424702 DISPOSAL REGULAR FEES	848,525	917,012	1,008,645	850,000	950,000	58,645
014394 424703 DISPOSAL COMMERCIAL FEES	1,252,243	1,483,134	1,270,694	1,200,000	1,200,000	70,694
014394 427010 RECYCLE NEWSPAPER	25,700	(11,696)	(18,985)	-	-	(18,985)
014394 427011 RECYCLE BOTTLES	16,588	22,662	18,745	12,500	12,500	6,245
014394 427012 RECYCLE OTHER ITEMS	4,352	2,283	1,653	-	-	1,653
014394 427013 RECYCLE METAL	69,005	62,946	42,070	40,000	40,000	2,070
TOTAL WASTE DISPOSAL REVENUE	3,110,693	3,372,701	3,209,426	3,002,500	3,102,500	106,926
015104 BOARD OF HEALTH						-
-----						-
015104 432003 PHOTOCOPIES	1,638	1,214	952	-	-	952
015104 432025 TEST HOLES	17,600	21,670	15,950	15,000	15,000	950
015104 442001 HOTEL, MOTEL, INN	525	825	675	500	500	175
015104 442002 STABLE	2,640	1,360	1,310	800	800	510
015104 442004 JUNK COLLECTOR/RUBBISH HAULE	1,000	1,250	1,375	1,000	1,000	375
015104 442007 MASSAGE LICENSE	-	-	-	-	-	-
015104 442013 OTHER FOOD SERVICE LICENSE	21,995	19,445	19,410	18,000	18,000	1,410
015104 442014 TOBACCO LICENSE	1,175	1,275	1,350	500	500	850
015104 442015 FUNERAL DIRECTOR LICENSE	150	150	100	-	-	100
015104 445005 MISC LIC/PERMITS	13,300	13,675	12,925	12,000	12,000	925

TOWN OF HARWICH

Local Receipts

Local Receipts General Fund	Actual FY2018	Actual FY2019	Actual FY2020	Budget FY2021	Budget FY2022	2020 vs 2022 Variance
015104 445010 SEPTAGE CARRIER	3,725	3,855	2,875	2,000	2,000	875
015104 445011 SEWERAGE PERMITS	36,315	32,283	30,380	30,000	30,000	380
015104 445012 WELL PERMITS	1,485	1,140	840	1,000	1,000	(160)
015104 445027 SWIMMING POOL	2,850	3,990	3,310	2,000	2,000	1,310
015104 445029 HEALTH INSPECTION FEES	41,317	37,950	38,830	35,000	35,000	3,830
015104 484099 MISC REVENUE/ TRENCH INSP.	6,545	8,290	5,770	5,500	5,500	270
TOTAL BOARD OF HEALTH	152,261	148,372	136,052	123,300	123,300	12,752
015394 CHANNEL 18 TELEVISION STATION						-
-----						-
015394 432041 VIDEO TAPE COPIES	-	5	-	-	-	-
TOTAL CHANNEL 18 TELEVISION STATION	-	5	-	-	-	-
015404 COMMUNITY CENTER REVENUE						-
-----						-
015404-432003 PHOTOCOPIES	78	102	60	-	-	60
015404 432044 PROGRAM FEES	2,890	3,815	2,717	2,000	1,000	1,717
015404 42049 PASSPORT FEES	14,570	18,264	12,200	12,000	6,000	6,200
015404 436004 BUILDING USE	20,970	20,435	12,165	10,000	5,000	7,165
015404 484098 COM CENTER WEIGHT ROOM USE	-	-	11,702	15,000	1,000	10,702
TOTAL COMMUNITY CENTER REVENUE	38,508	42,616	38,845	39,000	13,000	25,845
015414 COUNCIL ON AGING						-
-----						-
015414 432044 PROGRAM FEES	15,684	15,846	12,389	5,000	1,000	11,389
015414 483003 CATERING REVENUE	1,145	2,428	2,684	1,100	-	2,684
TOTAL COUNCIL ON AGING	16,829	18,274	15,073	6,100	1,000	14,073
016104 LIBRARY REVENUE						-
-----						-
016104 447003 FINES	5,565	5,814	3,026	-	-	3,026
TOTAL LIBRARY REVENUE	5,565	5,814	3,026	-	-	3,026
016304 RECREATION & YOUTH REVENUE						-
-----						-
016304 427014 BEACH CONCESSIONS	17,798	11,507	12,334	10,000	10,000	2,334
016304 432030 SUMMER PROGRAM FEES	9,425	15,250	7,790	2,000	2,000	5,790
016304 432044 PROGRAM FEES	1,695	2,130	495	500	500	(5)
016304 445013 BEACH STICKERS	296,164	319,246	315,915	275,000	300,000	15,915
016304 445014 BEACH PARKING	88,555	87,415	89,100	42,500	50,000	39,100
TOTAL RECREATION & YOUTH REVENUE	413,637	435,548	425,634	330,000	362,500	63,134
016334 HARBORMASTER REVENUE						-
-----						-
016334 432042 MOORING AGENT FEES	600	600	1,200	500	500	700
016334 436000 SLIP WAITING LIST FEES	10,064	10,640	11,444	10,000	10,000	1,444
016334 436001 HARBOR FUEL CONCESSION	6,449	7,597	9,316	9,000	9,000	316
016334 436002 ALLEN HARBOR PARKING RENTAL	10,900	10,900	22,785	20,000	20,000	2,785
016334 436010 ARTISAN AND TICKET BOOTH	-	-	9,400	-	5,000	4,400
016334 436012 SNACK SHACK LEASE	-	-	32,737	-	30,000	2,737
016334 436300 SEASONAL DOCKAGE	729,951	551,950	739,889	725,000	725,000	14,889
016334 436400 VISITOR DOCKAGE	112,738	154,163	235,711	200,000	200,000	35,711
016334 445014 PARKING	-	1,970	-	-	-	-
016334 445200 OFFLOAD/WEIR PERMITS	28,106	35,013	40,182	35,000	35,000	5,182
016334 454012 RAMP FEES/PASSES	-	32,142	32,327	25,000	25,000	7,327
016334 469900 OTHER STATE REVENUE	29,285	-	34,425	-	-	34,425
016334 454010 Misc	1,680	1,780	4,464	-	-	4,464
TOTAL HARBORMASTER REVENUE	929,773	806,754	1,173,879	1,024,500	1,059,500	114,379
016914 HISTORIC COMM REVENUE						-

TOWN OF HARWICH

Local Receipts

Local Receipts General Fund	Actual FY2018	Actual FY2019	Actual FY2020	Budget FY2021	Budget FY2022	2020 vs 2022 Variance
016914 437001 HEARINGS	715	1,210	770	500	500	270
TOTAL HISTORIC COMM REVENUE	715	1,210	770	500	500	270
016954 GOLF OPERATIONS REVENUE						-
016954 427002 SNACK BAR CONCESSION	-	15,000	-	-	-	-
016954 432031 GREENS FEES	787,622	754,762	500,160	650,000	750,000	(249,840)
016954 432032 DRIVING RANGE	71,523	72,858	55,930	50,000	65,000	(9,070)
016954 432033 PULL CARTS	8,625	8,087	5,239	5,000	5,000	239
016954 432034 RESIDENTS FEES	690,839	718,012	670,032	650,000	700,000	(29,968)
016954 432035 CART RENTAL	246,824	265,011	210,450	200,000	250,000	(39,550)
016954 432046 NON RESIDENT GOLF MEMBERS	32,375	16,765	20,250	20,000	20,000	250
016954 432047 GOLF RANGE MEMBERSHIP	14,500	18,255	12,255	10,000	10,000	2,255
016954 432056 MEMBER CAPITAL FEE		21,428	20,215			20,215
016954 484099 MISC REVENUE	3,914	5,720	24,404	0	0	24,404
TOTAL GOLF OPERATIONS REVENUE	1,856,221	1,895,899	1,518,934	1,585,000	1,800,000	(281,066)
Sub Total Local Receipts	\$ 9,994,283	\$ 11,192,026	\$ 10,547,307	\$ 9,390,520	\$ 9,740,198	807,109
011464-484099 MOTOR VECH. & BOAT	\$ 2,372,767	\$ 2,407,537	\$ 2,294,565	\$ 1,925,000	\$ 2,025,000	269,565
011414-469901 MOTEL & HOTEL TAX	674,717	684,793	905,397	456,000	700,000	205,397
Total Local Receipts	\$ 13,041,767	\$ 14,284,356	\$ 13,747,270	\$ 11,771,520	\$ 12,465,198	1,282,072
011414 699001 MEALS TAX	423,305	439,960	445,497	215,000	215,000	230,497
Total LOCAL RECEIPTS	\$ 13,465,072	\$ 14,724,316	\$ 14,192,766	\$ 11,986,520	\$ 12,680,198	1,512,568

<u>TOWN OPERATION BUDGET 2022</u>		<u>Actual FY2018</u>	<u>Actual FY2019</u>	<u>Actual FY2020</u>	<u>Budget FY2021</u>	<u>TA Proposed FY2022</u>	<u>\$\$ Change</u>	<u>PCT CHANGE</u>
1	MODERATOR S&W	-	-	-	1,000	1,000	-	0.0%
2	SELECTMEN S&W	7,500	12,000	12,000	12,500	12,500	-	0.0%
3	SELECTMEN - EXP	7,077	7,237	5,737	8,750	8,750	-	0.0%
4	Sub-Total	14,577	19,237	17,737	21,250	21,250	-	0.0%
5	FINANCE COMMITTEE S&W	745	229	76	3,000	3,000	-	0.0%
6	FINANCE COMMITTEE - EXP	809	1,516	1,824	2,000	2,000	-	0.0%
7	Sub-Total	1,554	1,744	1,900	5,000	5,000	-	0.0%
8	FINANCE COMMITTEE RESERVE FUND	-	-	-	50,000	50,000	-	0.0%
9	TOWN ACCOUNTANT - SAL	233,658	246,777	258,180	265,485	278,184	12,699	4.8%
10	TOWN ACCOUNTANT - EXP	3,626	2,570	6,990	7,875	8,139	264	3.4%
11	AUDIT - EXP	37,900	40,505	40,000	40,000	40,000	-	0.0%
12	Sub-Total	275,183	289,853	305,170	313,360	326,323	12,963	4.1%
13	ASSESSORS - S&W	153,113	182,201	178,746	204,048	206,287	2,239	1.1%
14	ASSESSORS - EXP	68,266	97,871	85,332	110,520	108,220	(2,300)	-2.1%
15	Sub-Total	221,379	280,071	264,078	314,568	314,507	(61)	0.0%
16	TOWN COLLECTIONS - S&W	12,476	12,837	9,425	16,000	16,000	-	0.0%
17	TOWN COLLECTIONS - EXP	3,154	3,760	3,700	5,500	5,500	-	0.0%
18	Sub-Total	15,631	16,597	13,125	21,500	21,500	-	0.0%
19	POSTAGE	46,452	39,128	47,487	41,500	41,500	-	0.0%
20	Sub-Total	46,452	39,128	47,487	41,500	41,500	-	0.0%
21	TREASURER - S&W	234,025	254,705	276,730	288,776	291,686	2,910	1.0%
22	TREASURER - EXP	102,106	97,616	101,573	95,358	91,550	(3,808)	-4.0%
23	Sub-Total	336,131	352,322	378,303	384,134	383,236	(898)	-0.2%
24	VACATION & SICK LEAVE BUY BACK	-	46,074	84,023	138,728	150,622	11,894	8.6%
25	MEDICARE	217,264	236,704	253,229	242,888	255,008	12,120	5.0%
26	ADMINISTRATION - S&W	418,242	425,860	494,694	469,123	397,945	(71,178)	-15.2%
27	ADMINISTRATION - EXP	75,450	74,692	85,053	96,880	119,879	22,999	23.7%
28	ADMINISTRATION - CAP OUTLAY	4,958	4,801	3,013	5,500	5,500	-	0.0%
29	WEATHER EVENT	-	-	844,876	-	-	-	0.0%
30	Sub-Total	498,651	505,352	1,427,636	571,503	523,324	(48,179)	-8.4%
32	LEGAL SERVICES - EXP	159,374	170,825	140,192	185,000	185,000	-	0.0%
33	CLAIMS & SUITS	-	-	-	500	500	-	0.0%
34	Sub-Total	159,374	170,825	140,192	185,500	185,500	-	0.0%
35	INFORMATION TECHNOLOGY - S&W	99,800	101,439	108,577	111,098	111,098	-	0.0%
36	INFORMATION TECHNOLOGY - EXP	211,708	244,542	202,496	276,250	274,141	(2,109)	-0.8%
37	Sub-Total	311,507	345,981	311,073	387,349	385,240	(2,109)	-0.5%
38	IT CHANNEL 18 - S&W	106,300	117,843	128,625	143,627	149,496	5,869	4.1%
39	IT CHANNEL 18 - EXP	24,790	28,089	15,772	66,480	60,604	(5,876)	-8.8%
40	Sub-Total	131,091	145,933	144,397	210,107	210,100	(7)	0.0%
41	CONSTABLE S & W	356	188	375	708	708	-	0.0%
42	TOWN CLERK - S&W	202,280	229,276	240,754	272,756	240,726	(32,030)	-11.7%
43	TOWN CLERK - EXP	30,684	33,186	51,130	49,300	32,228	(17,072)	-34.6%
44	Sub-Total	232,964	262,462	291,884	322,056	272,954	(49,102)	-15.2%
45	CONSERVATION - S&W	111,527	138,789	148,974	168,022	165,506	(2,516)	-1.5%
46	CONSERVATION - EXP	6,673	8,198	4,891	7,565	5,915	(1,650)	-21.8%
47	Sub-Total	118,200	146,987	153,865	175,587	171,421	(4,166)	-2.4%
48	TOWN PLANNER - S&W	69,515	87,324	93,093	95,480	95,305	(175)	-0.2%
49	TOWN PLANNER - EXP	1,928	3,580	3,428	4,531	4,531	-	0.0%
50	Sub-Total	71,443	90,904	96,520	100,011	99,836	(175)	-0.2%
51	BOARD OF APPEALS - S&W	-	-	-	-	-	-	0.0%

<u>TOWN OPERATION BUDGET 2022</u>		<u>Actual FY2018</u>	<u>Actual FY2019</u>	<u>Actual FY2020</u>	<u>Budget FY2021</u>	<u>TA Proposed FY2022</u>	<u>\$\$ Change</u>	<u>PCT CHANGE</u>
52	BOARD OF APPEALS - EXP	594	15	124	735	735	-	0.0%
53	Sub-Total	594	15	124	735	735	-	0.0%
54	ALBRO HOUSE - EXP	3,148	2,928	2,177	6,355	6,355	-	0.0%
55	OLD RECR BUILDING - EXP	5,321	4,123	5,001	7,627	7,627	-	0.0%
56	W. HARWICH SCHOOL - EXP	408	404	365	1,424	1,424	-	0.0%
57	Sub-Total	8,876	7,455	7,543	15,405	15,405	-	0.0%
58	COMMUNITY DEVELOPMENT - S&W	218,879	225,761	211,842	242,945	235,150	(7,795)	-3.2%
59	COMMUNITY DEVELOPMENT - EXP	10,834	9,207	6,596	13,113	13,113	-	0.0%
60	Sub-Total	229,713	234,968	218,438	256,058	248,263	(7,795)	-3.0%
61	PUBLIC BUILDINGS REPAIRS	-	-	-	2,133	2,133	-	0.0%
62	TOWN/FIN COM REPORTS	7,658	7,766	5,961	10,000	10,000	-	0.0%
63	ADVERTISING	21,671	22,229	4,788	22,750	22,750	-	0.0%
64	POLICE - S&W	3,384,205	3,716,952	3,554,438	4,041,890	4,267,392	225,502	5.6%
65	POLICE - EXP	544,305	484,541	375,889	506,643	493,737	(12,906)	-2.5%
66	POLICE - CAP OUTLAY	121,482	131,100	85,811	60,000	-	(60,000)	0.0%
67	Sub-Total	4,049,992	4,332,593	4,016,139	4,608,533	4,761,130	152,596	3.3%
68	FIRE - S&W	3,353,682	3,872,857	3,744,052	4,129,052	4,209,768	80,716	2.0%
69	FIRE - EXP	394,875	362,291	356,867	406,192	551,329	145,137	35.7%
71	Sub-Total	3,748,556	4,235,148	4,100,920	4,535,244	4,761,097	225,852	5.0%
72	AMBULANCE - S&W	112,767	137,969	86,233	131,607	Merged w/Fire	(131,607)	-100.0%
73	EMS - EXP	136,314	118,467	122,332	124,095	Merged w/Fire	(124,095)	-100.0%
74	Sub-Total	249,081	256,436	208,565	255,702	-	(255,702)	-100.0%
75	BUILDING - S&W	246,408	291,192	283,536	337,190	336,170	(1,020)	-0.3%
76	BUILDING - EXP	11,349	13,822	10,568	24,976	26,475	1,499	6.0%
77	Sub-Total	257,757	305,013	294,104	362,166	362,645	479	0.1%
78	EMERG. MGMT - S&W	2,444	1,032	2,300	5,355	5,355	-	0.0%
79	EMERG. MGMT - EXP	3,317	4,562	7,075	8,500	8,500	-	0.0%
80	Sub-Total	5,761	5,593	9,375	13,855	13,855	-	0.0%
81	NATURAL RESOURCES - S&W	96,343	102,223	110,546	113,631	114,714	1,083	1.0%
82	NATURAL RESOURCES - EXP	26,998	27,835	21,525	28,200	27,100	(1,100)	-3.9%
83	Sub-Total	123,341	130,058	132,071	141,831	141,814	(17)	0.0%
84	PLEASANT BAY ALLIANCE	17,343	20,160	23,760	23,760	23,760	-	0.0%
85	TOWN ENGINEER - S&W	174,256	131,618	115,709	114,549	114,549	-	0.0%
86	TOWN ENGINEER - EXP	9,831	22,695	28,677	80,310	30,310	(50,000)	-62.3%
87	Sub-Total	184,088	154,313	144,386	194,859	144,859	(50,000)	-25.7%
88	HIGHWAY - S&W	2,495,639	2,623,322	2,578,958	2,848,196	2,771,009	(77,186)	-2.7%
89	HIGHWAY - EXP	2,501,442	2,805,897	2,690,057	3,226,579	3,303,765	77,186	2.4%
90	Sub-Total	4,997,081	5,429,219	5,269,015	6,074,775	6,074,775	(0)	0.0%
91	SNOW/ICE - S&W	104,576	81,499	25,914	40,000	40,000	-	0.0%
92	SNOW/ICE - EXP	260,924	190,965	66,955	95,000	95,000	-	0.0%
93	Sub-Total	365,500	272,463	92,870	135,000	135,000	-	0.0%
94	STREET LIGHTS	31,372	22,731	30,356	35,000	31,000	(4,000)	-11.4%
95	INTERGOVERNMENTAL TRANS - WW		70,000	125,000	200,000	515,331	315,331	157.7%
96	COUNTY WW SUPPORT FUND			100,000	-	-	-	0.0%
97	CEMETERY ADMIN - S&W	63,203	65,070	70,040	71,434	71,434	-	0.0%
98	CEMETERY ADMIN - EXP	3,164	4,546	4,670	5,075	5,108	33	0.6%
99	Sub-Total	66,367	69,617	74,710	76,509	76,542	33	0.0%
100	BOARD OF HEALTH - S&W	139,795	163,782	183,249	203,881	193,196	(10,685)	-5.2%
101	BOARD OF HEALTH - EXP	16,209	13,241	8,331	16,390	12,560	(3,830)	-23.4%
102	Sub-Total	156,004	177,023	191,579	220,272	205,756	(14,515)	-6.6%
103	COMMUNITY CENTER S&W	165,498	176,286	185,474	193,389	196,876	3,487	1.8%

TOWN OPERATION BUDGET 2022		Actual FY2018	Actual FY2019	Actual FY2020	Budget FY2021	TA Proposed FY2022	\$\$ Change	PCT CHANGE
104	COMMUNITY CENTER EXP	131,306	117,063	109,175	125,354	121,190	(4,164)	-3.3%
105	Sub-Total	296,804	293,349	294,649	318,743	318,066	(678)	-0.2%
106	COUNCIL ON AGING - S&W	370,042	352,597	361,824	396,169	393,012	(3,157)	-0.8%
107	COUNCIL ON AGING - EXP	63,690	63,932	55,274	79,232	82,326	3,094	3.9%
108	Sub-Total	433,732	416,529	417,099	475,401	475,338	(63)	0.0%
109	YOUTH COUNSELOR - S&W	81,511	85,203	93,443	96,255	96,855	600	0.6%
110	YOUTH COUNSELOR - EXP	4,017	4,604	4,221	3,485	3,485	-	0.0%
111	Sub-Total	85,528	89,807	97,663	99,740	100,340	600	0.6%
112	VETERANS EXPENSE/BENEFITS	99,997	97,461	133,899	128,058	144,277	16,219	12.7%
113	DISABILTY RIGHT - EXP	-	300	-	500	500	-	0.0%
114	HUMAN SERVICES	72,605	78,690	79,450	83,250	83,250	-	0.0%
115	LIBRARY - S&W	630,719	665,422	696,848	730,885	737,977	7,092	1.0%
116	LIBRARY - EXP	269,410	267,370	248,848	274,820	274,820	-	0.0%
117	Sub-Total	900,128	932,792	945,695	1,005,705	1,012,797	7,092	0.7%
118	RECREATION - SEASONAL - S&W	174,725	216,097	208,379	218,026	213,213	(4,813)	-2.2%
119	RECREATION - S&W	228,268	245,726	253,706	272,618	274,076	1,457	0.5%
120	RECREATION - EXP	41,735	46,281	52,966	45,575	45,575	-	0.0%
121	RECREATION - CAP OUTLAY	-	9,029	-	-	-	-	0.0%
122	Sub-Total	444,728	517,133	515,051	536,219	532,864	(3,356)	-0.6%
123	HARBORMASTER -S&W	289,490	311,293	324,299	343,404	342,729	(675)	-0.2%
124	HARBORMASTER - EXP	171,596	203,466	107,197	252,580	253,230	650	0.3%
125	Sub-Total	461,086	514,759	431,496	595,984	595,959	(25)	0.0%
126	BROOKS ACAD MUSEUM COMMISSION	10,754	9,440	7,842	12,894	12,894	-	0.0%
127	HISTORICAL COMMISSION	540	-	-	-	-	-	0.0%
128	HISTORICAL COMMISSION	-	198	-	350	350	-	0.0%
129	Sub-Total	540	198	-	350	350	-	0.0%
130	CELEBRATIONS	1,299	992	-	1,600	1,600	-	0.0%
131	GOLF - S&W	798,628	865,827	795,295	919,180	937,540	18,360	2.0%
132	GOLF - EXP	621,381	614,144	535,217	665,271	639,223	(26,048)	-3.9%
133	GOLF CAP OUTLAY	66,277	66,199	13,829	68,000	68,000	-	0.0%
134	Sub-Total	1,486,286	1,546,170	1,344,341	1,652,451	1,644,763	(7,688)	-0.5%
135	GOLF IMA MRSD	-	82,000	82,000	83,538	83,538	-	0.0%
136	ELECTRICITY - CVEC	66,254	68,140	71,705	73,900	75,750	1,850	2.5%
137	INTERFUND TRANSFERS	-	-	100,558	-	-	-	0.0%
138	Total Departmental Budgets	21,532,254	23,350,924	23,502,145	25,739,671	26,048,163	308,492	1.2%
139	Total Debt Service (Prin & Int)	2,494,459	4,710,046	4,920,069	4,617,408	5,178,305	560,897	12.1%
140	STATE ASSESSMENTS	261,135	269,883	285,138	300,901	308,390	7,489	2.5%
141	BARNS CTY RETIREMENT	2,681,194	2,763,836	3,024,763	3,144,894	3,242,673	97,779	3.1%
142	CAPE COD COMMISSION ASSESSMENT	217,944	223,393	234,056	240,570	253,720	13,150	5.5%
143	BARNSTABLE COUNTY ASSESSMENT	203,280	208,362	218,307	223,101	236,649	13,548	6.1%
144	UNEMPLOYMENT COMPENSATION	5,087	32,401	16,281	20,000	20,000	-	0.0%
145	GROUP HEALTH INSURANCE	4,296,270	4,514,731	4,551,199	4,833,551	4,938,071	104,520	2.2%
146	OPEB	100,000	125,000	150,000	-	250,000	250,000	100.0%
147	GENERAL INSURANCE	656,366	726,142	805,793	854,470	877,726	23,256	2.7%
148	GENERAL INSURANCE DEDUCTIBLE	4,603	7,018	3,696	20,000	20,000	-	0.0%
149	TOTAL TOWN	32,452,592	36,931,737	37,711,447	39,994,565	41,373,697	1,379,132	3.4%
150	OVERLAY (Abatements/Exemptions)	413,262	450,000	437,775	400,000	450,000	50,000	12.5%
151	C C REGIONAL TECH HIGH	1,487,362	1,581,236	2,317,475	1,737,789	1,536,309	(201,480)	-11.6%
152	MONOMOY REG. SCH. DISTRICT							
153	TOTAL MRSD ASSESMENT	24,759,749	25,609,390	26,643,415	26,820,046	27,361,048	541,002	2.0%
154	TOTAL	59,112,965	64,572,363	67,110,112	68,952,400	70,721,055	1,768,655	2.6%

**Town of Harwich
Water Department
Budget 2022**

Expenditures	Actual FY 2018	Actual FY 2019	Actual FY 2020	Budget FY 2021	Budget FY 2022
Water Salaries & Wages	1,186,101	1,247,495	1,284,716	1,329,300	1,279,529
Water Expenses	1,281,198	1,289,949	1,048,389	1,460,140	1,462,195
OPEB	50,000	50,000	50,000	50,000	50,000
Debt Obligations	768,427	752,366	739,688	721,345	704,377
Retained Earnings	1,635,175	150,179			
Indirect Cost	650,178	732,843	720,295	730,290	727,304
	<u>5,571,078</u>	<u>4,222,832</u>	<u>3,843,088</u>	<u>4,291,075</u>	<u>4,223,405</u>

Revenue	Actual FY 2018	Actual FY 2019	Actual FY 2020	Budget FY 2021	Budget FY 2022
Water User Fees	3,562,136	3,621,354	3,672,392	4,384,189	4,298,631
Water Liens	17,059	25,019	11,400	20,241	17,826
Penalties & Interest	1,501	3,618	2,616	2,211	2,578
Other Water Services	299,054	330,677	306,987	347,341	355,195
Solar & Cell Revenue	295,153	275,660	230,454	198,903	208,955
Investment Revenue	-	24,088	25,086	21,200	21,200
Miscellaneous Revenue	77,479	54,981	41,740	54,331	54,331
Transfer In from Other Fund:	-	59,768	18,277	-	-
	<u>4,252,382</u>	<u>4,395,163</u>	<u>4,308,952</u>	<u>5,028,416</u>	<u>4,958,716</u>

**Town of Harwich
Wastewater Department
Budget 2022**

DESCRIPTION	Actual FY 2018	Actual FY 2019	Actual FY 2020	Budget FY 2021	Budget FY 2022
Salaries & Wages	-	-	-	80,489	78,099
Electric Utility	-	-	-	-	4,000
Gas Utility	-	-	-	-	600
Professional Services	-	-	6,000	192,443	398,286
Prof/Architectural Services	-	-	19,642	-	-
Printing Services & Supplies	-	-	-	-	650
Generator Maintenance	-	-	-	-	2,250
Indirect Cost	-	-	-	-	31,446
Total	-	-	25,642	272,932	515,331

Proposed Warrant Article

To see if the Town will vote to authorize the Board of Selectmen to grant a permanent easement to Cellco Partnership (d/b/a Verizon Wireless) for the installation and maintenance of fiber optic cables, communications equipment and related facilities in, on and under a portion of the Town-owned property located on Harbor Road and identified by the Assessors as Parcel 15-U23, on such terms and conditions and for such consideration, which may be nominal consideration, as the Board deems appropriate; to take any action relative thereto; and to act fully thereon.

April 7, 2017

The Town of Harwich
ATTN: Christopher Clark – Town Administrator
732 Main St.
Harwich, MA 02645

RE: Utility Company Pole # 98-3A located on property at 40 Harbor Rd., Harwich, MA 02646 owned by The Town of Harwich (“Property Owner,,)

Dear Mr. Clark :

To follow up on your recent conversation with Benjamin T. Madden, Cellco Partnership d/b/a Verizon Wireless has the authority and the consent of the Utility Company to install equipment on the Pole on the above property owned by the Property Owner.

The Property Owner grants consent for Verizon Wireless to access the Pole for the purpose of installing and maintaining equipment as shown on the attached drawings.

The installation and maintenance shall be at Verizon Wireless’s sole cost and expense, and the equipment shall remain on the Pole until removed by Verizon Wireless at its sole cost and expense.

Very truly yours,

Sean Conway
Engineer IV RE/Regulatory

Consented to by Property Owner: The Town of Harwich

By:  _____

Name: Christopher Clark – Town Administrator
Duly Authorized

Date: 4/10/17

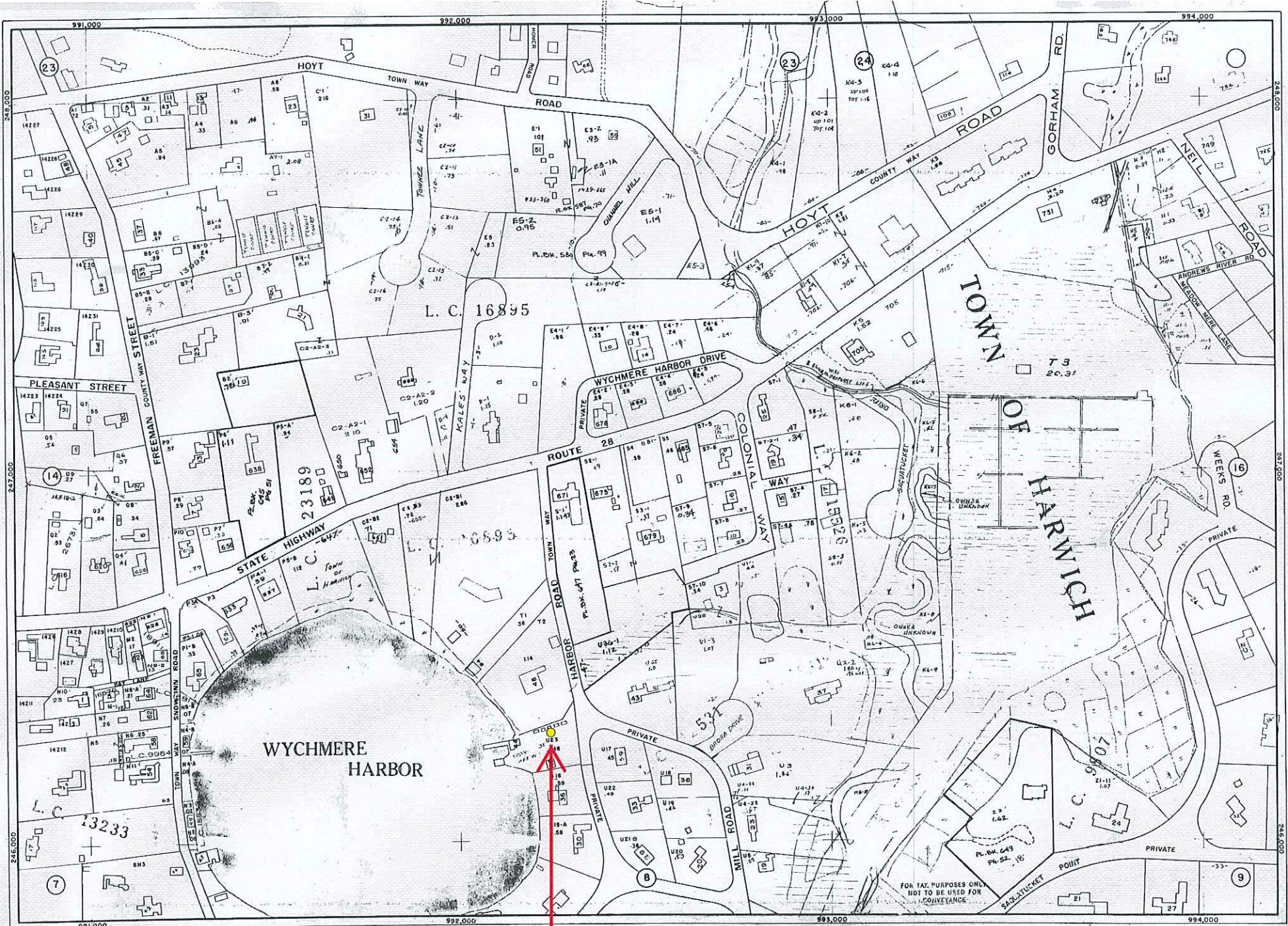

FOR TAX PURPOSES ONLY
NOT TO BE USED FOR
EVIDENCE

Key: 10567

Town of HARWICH - Fiscal Year 2016

12/7/2015 11:10 am SEQ #: 8.986

LEG
AL
LAND

CURRENT OWNER				PARCEL ID				LOCATION			
HARWICH TOWN OF - SELECTMEN WYCHMERE HARBOR LANDING 732 MAIN ST HARWICH, MA 02645				15-U23-0				40 HARBOR RD			
TRANSFER HISTORY				DOS	T	SALE PRICE	BK-PG (Cert)				
HARWICH TOWN OF - SELECTM				01/01/1932	E		(3000)				

CLASS	CLASS%	DESCRIPTION		BN ID	BN	CARD	
9310	100	IMP.SELECT/CITY CNCL			1	1 of 1	
PMT NO	PMT DT	TY	DESC	AMOUNT	INSP	BY	%
97		56	CYCL-NO GR		06/01/2015	DS	100
112	03/17/2005	56	CYCL-NO GR	4,000	04/14/2005	MO	100
495	03/26/1998	3	ALTERATIONS	400	05/02/2006	MO	100
	09/27/1989	1	NEW CONST	1,500	04/03/2003	MO	100
		2	ADDITIONS				100

CD	T	AC/SF/UN	Ngh	Inf1	Inf2	ADJ BASE	SAF	Topo	Lpi	VC	CREDIT AMT	ADJ VALUE	
100	S	20,909	16	1.00	DCK 1.00	100	1.00	1,818,110	1.56	100	1.00	8 13.30	1,363,530

TOTAL	20,909 SF	ZONING	FRNT	0	ASSESSED	CURRENT	PREVIOUS
Ngh	NGH 16	NOTE	LAND	1,363,500	1,336,600		
Inf1	DOCK/SLIP		BUILDING	19,200	19,100		
Inf2	FACTOR 100		DETACHED	1,762,200	5,200		
			OTHER	0	0		
			TOTAL	3,144,900	1,360,900		

TY	QUAL	COND	DIM/NOTE	YB	UNITS	ADJ PRICE	RCNLD
SHF	A	1.00 A-	0.70		40	15.98	400
SHF	A	1.00 A-	0.70		80	15.34	900
SHF	A	1.00 A-	0.70		96	15.34	1,000
SHF	A	1.00 A-	0.70		160	14.47	1,600
SHF	A	1.00 G+	0.95	1998	96	15.34	1,400
DCG	SV	1.00 SV	1.00	2015	131,198	13.39	1,756,900

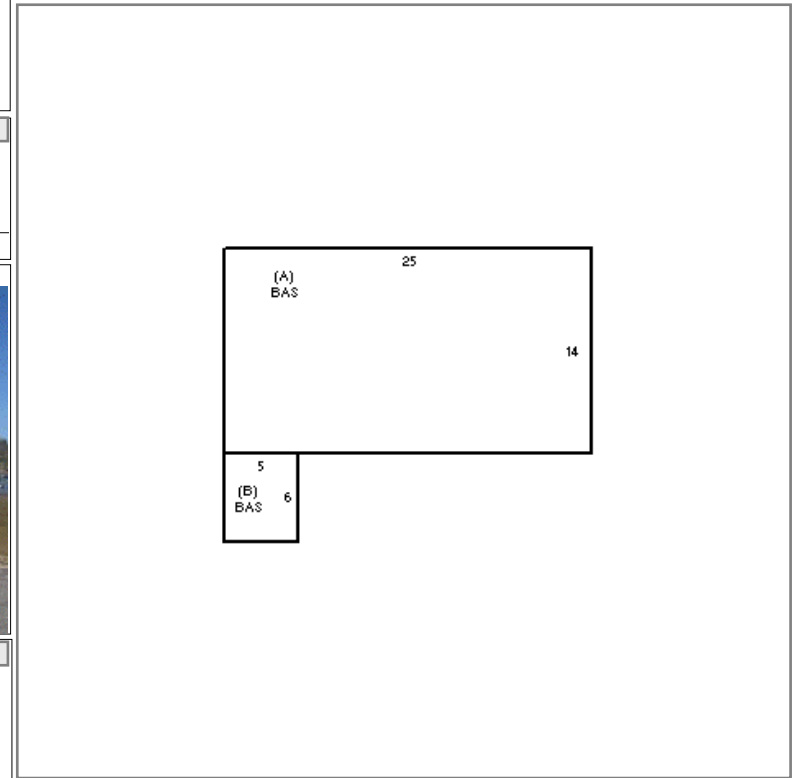

BUILDING	CD	ADJ	DESC	MEASURE	5/2/2006	MO
MODEL	5		CIM	LIST	4/14/2005	MO
STYLE	53	0.87	STORAGE GARAGE [100%]	REVIEW	5/10/2006	DS
QUALITY	A	1.00	AVERAGE [100%]			
FRAME	1	0.99	WOOD FRAME [100%]			

BLDG COMMENTS

DET
ACHED

B
U
I
L
D
I
N
G

YEAR BLT	1930	SIZE ADJ	1.760	ELEMENT	CD	DESCRIPTION	ADJ	S	BAT	T	DESCRIPTION	UNITS	YB	ADJ PRICE	RCN	TOTAL RCN	27,003
NET AREA	380	DETAIL ADJ	0.689	FOUNDATION	1	PIER	1.00	+	BAS	L	BASE AREA	380	1930	71.06	27,003	CONDITION ELEM	CD
\$NLA(RCN)	\$71	OVERALL	1.000	EXTERIOR WALL	1	WOOD SHINGLES	1.00										
CAPACITY				ROOF STRUCTURE	1	GABLE	1.00										
STORIES	1	ADJ	1.00	ROOF COVER	1	ASPH/COMP SHIN	1.00										
% HEATED	0		1.00	FLOORING	2	SOFTWOOD	0.95										
% A/C	0		1.00	INT FINISH	5	OTHER	1.00										
% SPRINKLERS	0		1.00	H.V.A.C.	13	NONE	0.90										
				FUEL SOURCE	99	N/A	1.00										
EFF.YR/AGE																1995 / 19	
COND																29 29%	
FUNC																0	
ECON																0	
DEPR																29 % GD 71	
RCNLD																\$19,200	

HARWICH SC13 MA
 LOCATION CODE: 390732
 UTILITY POLE NUMBER: 98-3A
 40 HARBOR ROAD, HARWICH, MA 02645



KEY PLAN

NOT TO SCALE

POLE COORDINATES	LATITUDE (WGS84)	LONGITUDE (WGS84)
	41° 40' 00.95" N	70° 03' 49.97" W
GROUND ELEVATION	26' AMSL (WGS84)	

LEASE EXHIBIT
 THIS LEASE IS SCHEMATIC IN NATURE AND IS INTENDED TO PROVIDE GENERAL INFORMATION REGARDING THE LOCATION AND SIZE OF THE PROPOSED WIRELESS COMMUNICATION FACILITY. THE SITE LAYOUT WILL BE FINALIZED UPON COMPLETION OF A SITE SURVEY AND FACILITY DESIGN.

PREPARED FOR:



REV	DATE	ISSUED FOR
△	1/15/16	FOR CLIENT REVIEW
△	5/19/16	FOR CLIENT REVIEW
△	8/8/16	FOR CLIENT REVIEW

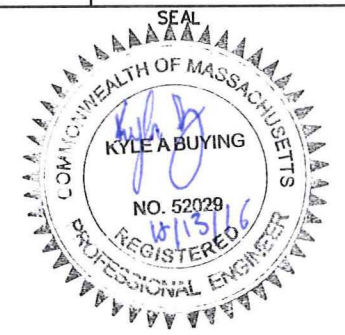

245 Commercial Street Suite 203, Portland, ME 04101
 T: (207) 591-6427
 info@tilsontech.com tilsontech.com

HARWICH SC13 MA
 40 HARBOR ROAD
 HARWICH, MA 02645
 BARNSTABLE COUNTY

KEY PLAN

DRAFTED BY: PZK 8/8/16	LE-1	REVISION: 2
---------------------------	------	----------------

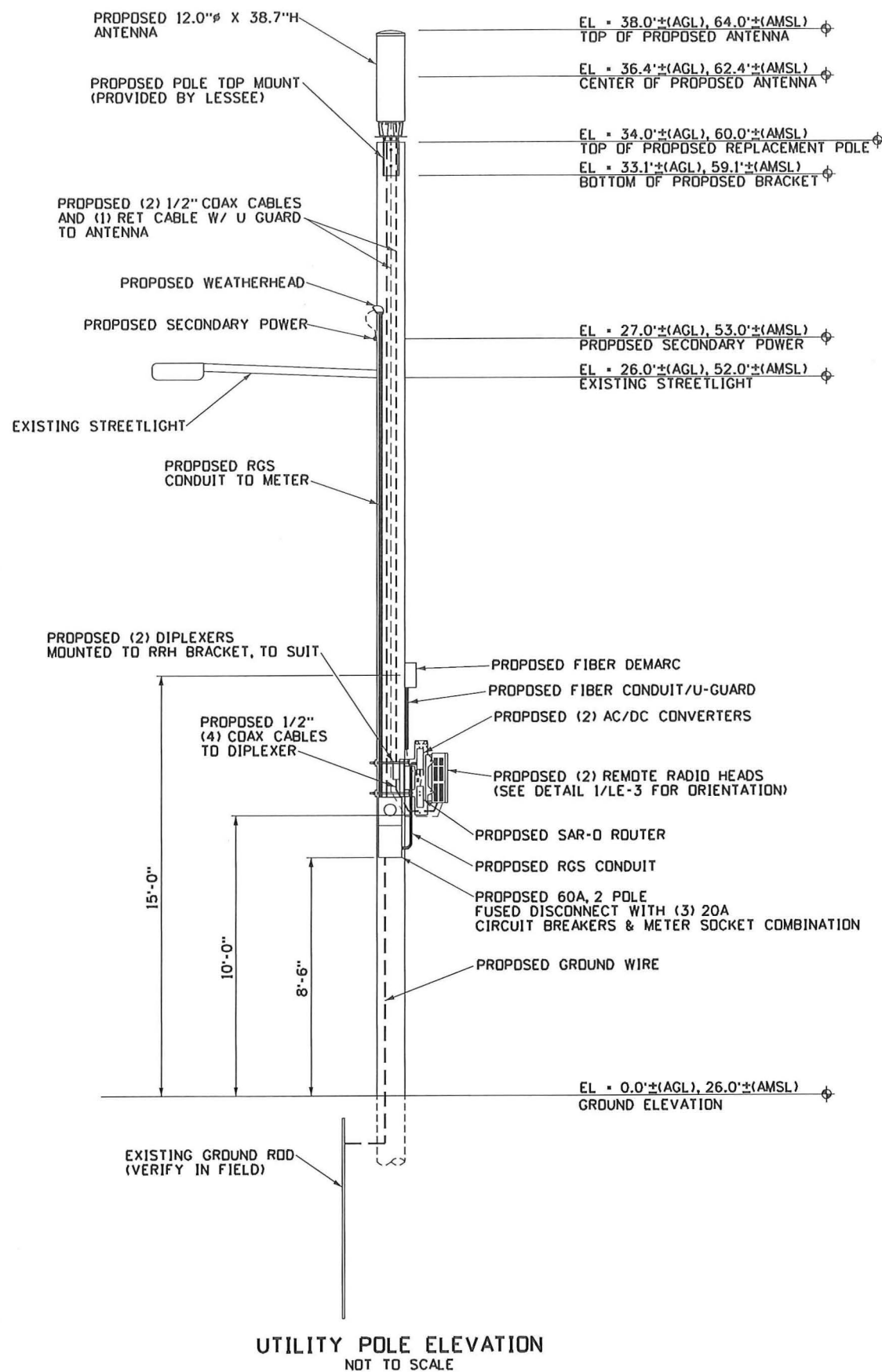

NOTES:

1. AN ANALYSIS OF THE CAPACITY OF THE EXISTING STRUCTURE TO SUPPORT THE PROPOSED LOADING HAS NOT BEEN COMPLETED BY TILSON. DRAWINGS ARE SUBJECT TO CHANGE PENDING OUTCOME OF A STRUCTURAL ANALYSIS.
2. LESSEE SHALL MAKE ARRANGEMENTS WITH THE LOCAL ELECTRICAL UTILITY, TO LOWER THE POSITION OF THE EXISTING OVERHEAD PRIMARY POWER LINES AT SUBJECT UTILITY POLE TO PROVIDE THE REQUIRED CLEARANCE FOR THE INSTALLATION OF THE PROPOSED LESSEE ANTENNA. THE PROPOSED INSTALLATION OF THE ANTENNA AND ALL APPURTENANCES SHALL MEET THE REQUIREMENTS OF NATIONAL GRID AND THE 2012 NATIONAL ELECTRICAL SAFETY CODE.



ELEVATION PHOTO
NOT TO SCALE

LEASE EXHIBIT
THIS LEASE IS SCHEMATIC IN NATURE AND IS INTENDED TO PROVIDE GENERAL INFORMATION REGARDING THE LOCATION AND SIZE OF THE PROPOSED WIRELESS COMMUNICATION FACILITY. THE SITE LAYOUT WILL BE FINALIZED UPON COMPLETION OF A SITE SURVEY AND FACILITY DESIGN.

PREPARED FOR:

REV	DATE	ISSUED FOR
△	1/15/16	FOR CLIENT REVIEW
△	5/19/16	FOR CLIENT REVIEW
△	8/8/16	FOR CLIENT REVIEW

245 Commercial Street Suite 203, Portland, ME 04101
T: (207) 591-6427
info@tilsontech.com tilson-tech.com

HARWICH SC13 MA
40 HARBOR ROAD
HARWICH, MA 02645
BARNSTABLE COUNTY

POLE
98-3A
ELEVATION

DRAFTED BY: PZK 8/8/16	LE-2	REVISION: 2
---------------------------	------	----------------

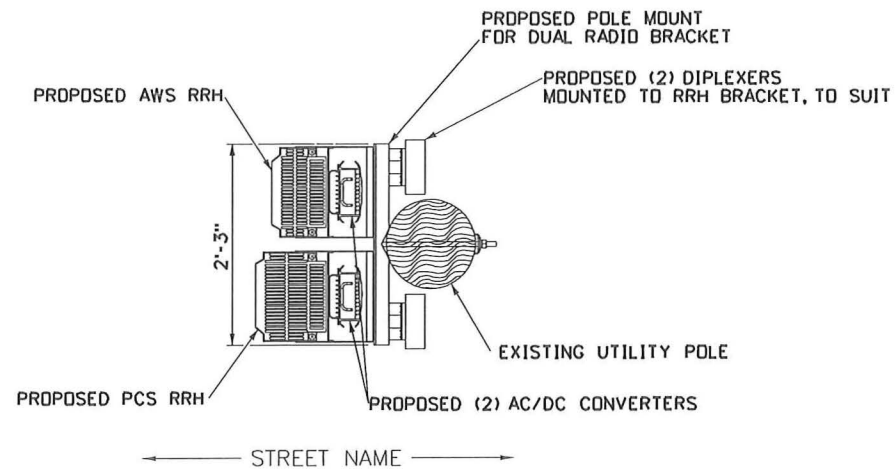

PROPOSED RRH ORIENTATION PLAN
NOT TO SCALE

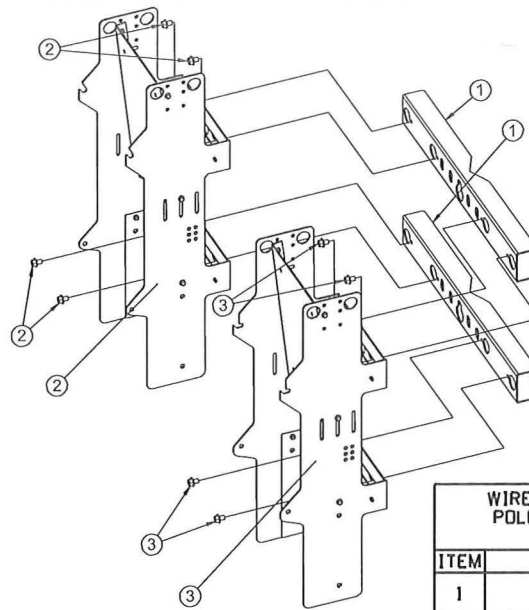

WIRELESS CONSTRUCTION, INC.
POLE/WALL MOUNT FOR DUAL
RADIO BRACKET

ITEM	DESCRIPTION	QTY.
1	DOUBLE MOUNT	2
2	PCS RRH RACK W/ SUPPLIED HARDWARE	1
3	AWS RRH RACK W/ SUPPLIED HARDWARE	1

PROPOSED RRH MOUNTING BRACKET SPECIFICATIONS
NOT TO SCALE

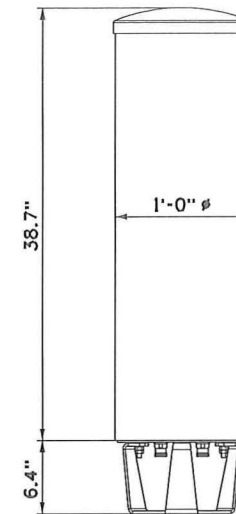

ANTENNA SPECIFICATIONS	
COMMSCOPE NH3600M-DG-2XR	
DIMENSIONS	12"Ø X 38.7"H
WEIGHT	33.7 LBS

PROPOSED ANTENNA SPECIFICATIONS
NOT TO SCALE

LEASE EXHIBIT
THIS LEASE IS SCHEMATIC IN NATURE AND IS INTENDED TO PROVIDE GENERAL INFORMATION REGARDING THE LOCATION AND SIZE OF THE PROPOSED WIRELESS COMMUNICATION FACILITY. THE SITE LAYOUT WILL BE FINALIZED UPON COMPLETION OF A SITE SURVEY AND FACILITY DESIGN.



REV	DATE	ISSUED FOR
△	1/15/16	FOR CLIENT REVIEW
△	5/19/16	FOR CLIENT REVIEW
△	8/8/16	FOR CLIENT REVIEW



HARWICH SC13 MA
40 HARBOR ROAD
HARWICH, MA 02645
BARNSTABLE COUNTY

EQUIPMENT DETAILS

DRAFTED BY: PZK 8/8/16	LE-3	REVISION: 2
---------------------------	------	----------------

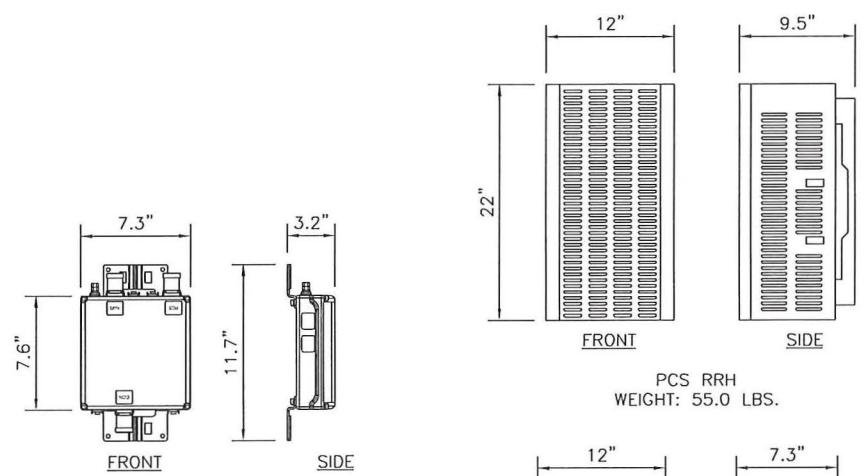

PROPOSED DIPLEXER SPECIFICATIONS
NOT TO SCALE

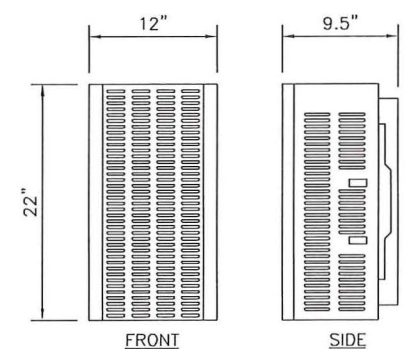

PCS RRH
WEIGHT: 55.0 LBS.

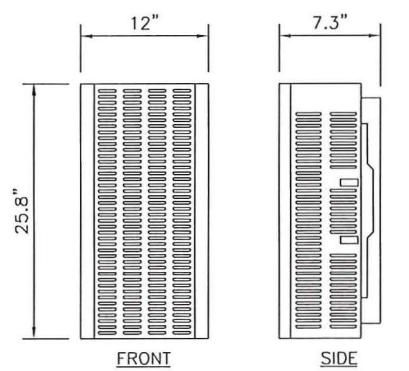

AWS RRH
WEIGHT: 67.0 LBS.
PROPOSED RRH SPECIFICATIONS
NOT TO SCALE

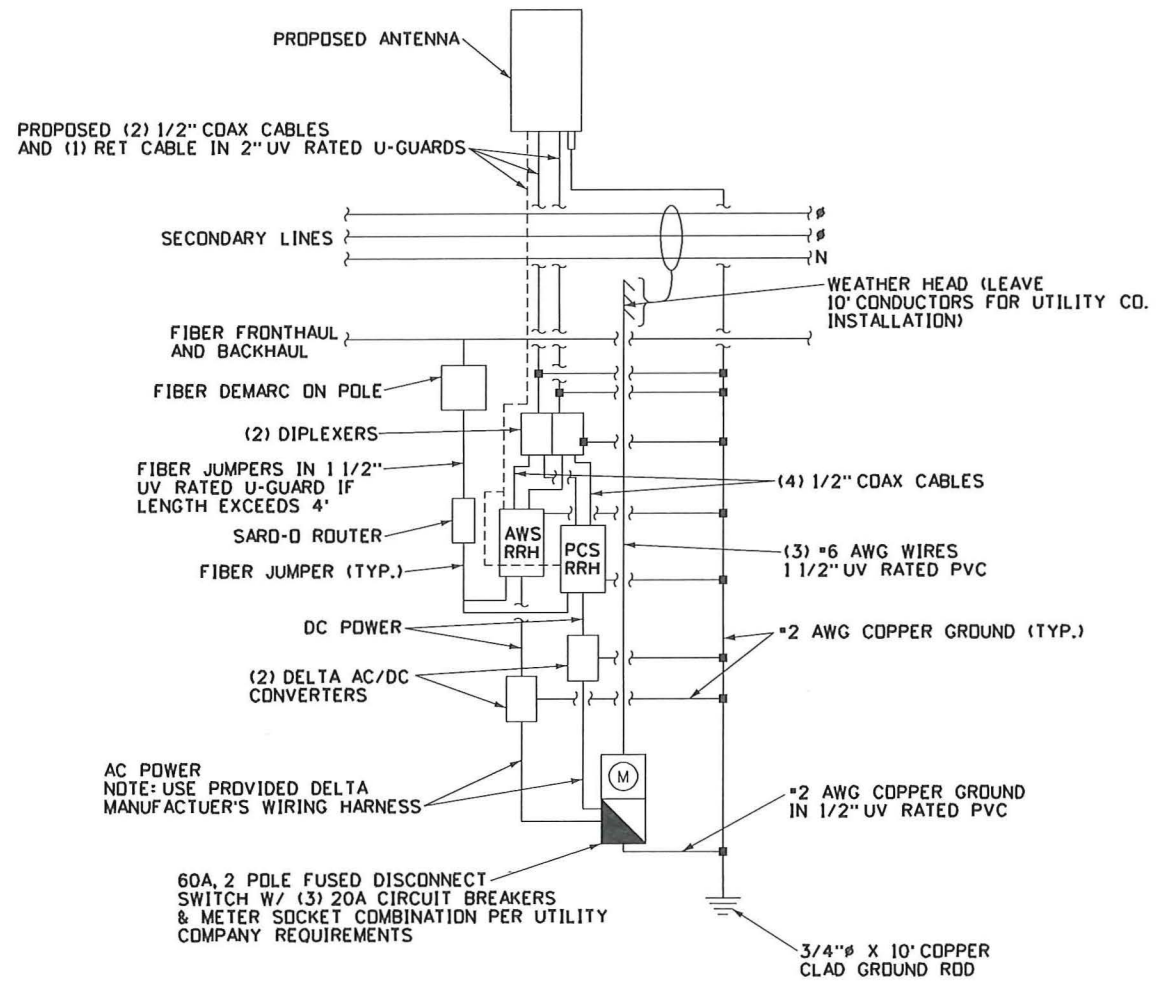

GENERAL WIRING DIAGRAM
NOT TO SCALE



CONTRACTS

OFFICE OF THE TOWN ADMINISTRATOR

Joseph F. Powers, *Town Administrator*
Meggan M. Eldredge, *Assistant Town Administrator*

Phone (508) 430-7513

Fax (508) 432-5039

732 MAIN STREET, HARWICH, MA 02645



Memo

To: Board of Selectmen
Joseph F. Powers, Town Administrator

From: Meggan Eldredge, Assistant Town Administrator
Griffin Ryder, Town Engineer

RE: Contract with Vermeer Mid Atlantic LLC for a Vermeer SC552 Stump Cutter

Date: March 24, 2021

This memorandum corresponds to *Contracts Agenda Item A. Discussion and possible vote for the Board of Selectmen to execute contract with Vermeer Mid Atlantic LLC for a Vermeer SC552 Stump Cutter in the amount of \$60,039.00.*

As you will see from the attached materials, this item was procured through the FAC-88 State Contract according to MGL, C. 30B. Funding for this purchase is proposed to be equally divided (\$20,013.00 each) out of three sources:

The Department of Environmental Protection State Recycling Fund
The Cemetery Department Revolving Fund
The Golf Department Capital Outlay Fund

I recommend the Board's approval and execution of this contract.

Project Name: Stump Grinder TM Year and Article #: FY 2021 Appropriation: \$ 60,039.00

Low Bidder: Vernier Mid-Atlantic Bid Price: \$ 60,039.00
FAC-88 State Contract *DEP State recycling* *Cemetery Revolving* *Gold Capital Outlay*

12/13/18 Revised Procurement Checklist

Please complete checklist below for contracts requiring Selectmen* signature **before Wednesday morning**** in order to get sign-off approval from the Town Administrator or the Assistant Town Administrator.

*Note: contracts (not grants) **below \$25,000** can be signed by Town Administrator.

- 1. Please provide a **separate page titled "Summary of Project"** which includes:
 - a. Provide how many bidders there were, the range of bids, and apparent low bidder. *NA*
 - b. Identify the funding source, such as article number and amount approved.
 - c. Include what you feel is pertinent, but keep this section to 4 sentences or less. Numerous
- 2. Finance Director has signed that funds are available: Carol Coppola Account # _____
- 3. Please provide a single **copy of the bid packet** along with all supporting documents.
- 4. Please use K-P Law provided standardized contracts.

<u>Buildings and Public Works</u>	<u>Goods and Services</u>
<input type="checkbox"/> C1. Please show Prevailing Wage was used. <input type="checkbox"/> C2. If construction is near \$10,000 you also need: <ul style="list-style-type: none"> <input type="checkbox"/> a. Written spec sheet. <input type="checkbox"/> b. Advertised for two weeks on Central Register and COMMBUYS. <input type="checkbox"/> c. Apparent low bidder posted to Town website. <input type="checkbox"/> C3. If construction over \$25,000 you need C1, C2, as well as: <ul style="list-style-type: none"> <input type="checkbox"/> a. Show project was in the Capital Plan. <input type="checkbox"/> b. Low bidder provides 50% payment bond after Selectmen's countersignature. <input type="checkbox"/> C4. If construction over \$50,000 you need C1, C2, C3, as well as: <ul style="list-style-type: none"> <input type="checkbox"/> a. Bid Bond of 5% of total value. <input type="checkbox"/> b. Sealed Bids. <input type="checkbox"/> c. End of Public Works construction requirements <input type="checkbox"/> C5. If Building estimated construction costs are over \$300,000 and estimated design costs are over \$30,000 you'll need to follow the Designer Selection RFQ process: <ul style="list-style-type: none"> <input type="checkbox"/> a. Advertise in Central Register and local newspaper for two weeks. <input type="checkbox"/> b. Set a designer fee or price ceiling. <input type="checkbox"/> c. Use Standard Designer Application Form <input type="checkbox"/> C6. If Building construction over \$150,000 you'll need C1, C2, C3, C4, C5, as well as: <ul style="list-style-type: none"> <input type="checkbox"/> a. 100% payment bond was in bids. <input type="checkbox"/> b. 100% performance bond was in bids. <input type="checkbox"/> c. DCAMM certified bidders. <ul style="list-style-type: none"> <input type="checkbox"/> i. DCAMM certified sub-bids if over \$25,000. <input type="checkbox"/> C7. If Building construction over \$10,000,000 you'll need C1, C2, C3, C4, C5, C6, as well as: <ul style="list-style-type: none"> <input type="checkbox"/> a. Solicit qualifications prior to sealed bids. 	<input type="checkbox"/> GS1. If procured using the State Bid List : <ul style="list-style-type: none"> <input type="checkbox"/> a. Over \$25,000 please show project was on the Capital Plan. <input type="checkbox"/> GS2. If project is over \$5,000 : <ul style="list-style-type: none"> <input type="checkbox"/> a. Please provide written spec sheet used and who it was sent to. <input type="checkbox"/> b. Maximum contract length is three years. <input type="checkbox"/> GS3. If project is over \$50,000 : <ul style="list-style-type: none"> <input type="checkbox"/> a. Show project was advertised for two weeks in a newspaper and on COMMBUYS. <input type="checkbox"/> b. Show project utilized sealed bids. <input type="checkbox"/> c. Apparent low bidder posted to Town website. <input type="checkbox"/> GS4. If project is over \$100,000 : <ul style="list-style-type: none"> <input type="checkbox"/> a. Show project was advertised for two weeks in COMMBUYS and Goods and Services Bulletin. <input type="checkbox"/> b. Show project utilized sealed bids. <p>Note 1: If lowest bidder was found to be either not responsive or not responsible, the Town may begin negotiations with next lowest bidder.</p> <p>Note 2: Bids may be negotiated downwards but never higher than original quote.</p> <p>Note 3: Municipalities shall not provide a down payment, deposit, or provide funding before possession of purchased item.</p> <p style="color: blue; font-style: italic;">FAC-88 State Contract</p>

Original for Accounting
 Original for Procurement
 Original for Vendor
 Contract to Treasurer's Signature of Town Administrator or Assistant Town Administrator: Joseph F. Powers

Note: Failure to gain sign-off **before Wednesday at noon results in the contract being delayed to the next meeting.

Summary of Project

Stump Grinder

This procurement is to purchase a Vermeer Stump Grinder model SC552 from State Contract FAC 88. This stump grinder is smallest, commercial grade grinder made by Vermeer and was recommended to us by the by the commercial tree companies that assisted the Town after the tornado in July 2019. The Town has approximately 700 stumps to be ground.

Funding:

- **Department of Environmental Protection State Recycling \$20013.00**
- **Cemetery Revolving \$20013.00**
- **Golf Capital Outlay \$20013.00**

PROCUREMENT CHECKLIST & APPROVAL FORM

STAFF LEAD: Lincoln Hooper

DEPARTMENT: DPW / Golf / Cemetery

FUNDING SOURCE: Split 3 ways with Golf, Cemetery and DPW

Appropriated amount: \$0.00

Estimated cost: _____ **Actual cost:** \$60,039.00

PROCUREMENT METHOD:

State Contract # FAC 88

PURCHASE DESCRIPTION:

Purchase descriptions should contain the following components (see document on purchase descriptions):
Description of supplies or services required; quantities required; schedule for performance and delivery terms.

This procurement is to purchase a Vermeer Stump Grinder model SC552 from State Contract FAC 88. This stump grinder is smallest, commercial grade grinder made by Vermeer and was recommended to us by the by the commercial tree companies that assisted the Town after the tornado in July 2019. The Town still has approximately 700 stumps to be ground, with the vast majority being in the cemeteries and at the golf course.

Funding for this purchase is proposed as follows:

Department of Environmental Protection (DEP) State Recycling	\$20,013
Cemetery Revolving	\$20,013
Golf Capital Outlay	\$20,013

PROCUREMENT MAY PROCEED ONLY IF SIGNATURES PROVIDED BELOW

Funds Available: Finance Director: Carol Coppola Account # see below
40C32039B33D434...

State Recycling 12054392/558000, Cemetery Revolving 16111002/558000 and Golf Capital Outlay 016958/585000
0623C0C5799644E...

Approved to proceed: Town Administrator or Designee: Joseph T. Powers
0623C0C5799644E...



QUOTE X
 SALES ORDER
 DELIVERY RECEIPT

NO:	
DATE:	12/8/20
PURCHASE ORDER:	

SOLD TO:	Town of Harwich				
ADDRESS:	273 Queen Ann Rd				
CITY:	Harwich	STATE:	MA	ZIP:	02645
CUSTOMER CONTRACT:					

SHIP TO:					
ADDRESS:					
CITY:		STATE:		ZIP:	
TERMS:					

Terms are due upon receipt unless otherwise specified

Phone:	508-430-7572	Fax:		Mobile:		Other#:	
--------	--------------	------	--	---------	--	---------	--

SALESPERSON	SHIP VIA	DATE REQUIRED	UNIT #	NOTE
Bill McGowan	VAR			

QTY	STOCK NUMBER / DESCRIPTION	PRICE	TOTAL
	Vermeer SC552 Self Propelled Rubber Tire Stump Cutter		
	56hp Kohler Diesel, Low oil pressure/High coolant temp		
	Shutdown, Electric over Hydraulic joystick controls,		
	Swing out control station, Chip curtains, Auto Sweep,		
	Front auxiliary propel functions		\$60,039.00
	FAC-88 State Contract Pricing		

SUBTOTAL	
DEPOSIT	
TAX	
TOTAL	\$60,039.00

Accepted By: _____

Thank You For Choosing Vermeer Mid Atlantic!

AGREEMENT FOR TOWN OF HARWICH

The following provisions shall constitute an Agreement between the Town of Harwich, acting by and through its Board of Selectmen, hereinafter referred to as "Town," and Vermeer Mid Atlantic LLC, with an address of 224 South Street, Hopkington, MA 01748, hereinafter referred to as "Contractor", effective as of the _____ day of March, 2021. In consideration of the mutual covenants contained herein, the parties agree as follows:

ARTICLE 1: SCOPE OF WORK:

The Contractor shall perform all work and furnish all supplies necessary to provide the Town with a Vermeer (SC552) Self Propelled Rubber Tire Stump Cutter, including the scope of supplies set forth in Attachment A.

ARTICLE 2: TIME OF PERFORMANCE:

The Contractor shall complete all work and supplies required hereunder commencing upon contract execution through April 15, 2021.

ARTICLE 3: COMPENSATION:

The Town shall pay the Contractor for the performance of the work outlined in Article 1 above the contract sum of \$60,039.00. The Contractor shall submit monthly invoices to the Town for supplies rendered, which will be due 30 days following receipt by the Town.

ARTICLE 4: CONTRACT DOCUMENTS:

The following documents form the Contract and all are as fully a part of the Contract as if attached to this Agreement or repeated herein:

1. This Agreement.
2. Amendments, or other changes mutually agreed upon between the parties.
3. All attachments to the Agreement.

4. The Commonwealth of Massachusetts Operational Services Division FAC88: Lawns & Grounds, Equipment, Parts and Services Statewide Contract.

In the event of conflicting provisions, those provisions most favorable to the Town shall govern.

ARTICLE 5: CONTRACT TERMINATION:

The Town may suspend or terminate this Agreement by providing the Contractor with ten (10) days written notice for the reasons outlined as follows:

1. Failure of the Contractor, for any reason, to fulfill in a timely and proper manner its obligations under this Agreement.
2. Violation of any of the provisions of this Agreement by the Contractor.
3. A determination by the Town that the Contractor has engaged in fraud, waste, mismanagement, misuse of funds, or criminal activity with any funds provided by this Agreement.

Either party may terminate this Agreement at any time for convenience by providing the other party written notice specifying therein the termination date which shall be no sooner than thirty (30) days from the issuance of said notice. Upon receipt of a notice of termination from the Town, the Contractor shall cease to incur additional expenses in connection with the Agreement. Upon such termination, the Contractor shall be entitled to compensation for all satisfactory work completed prior to the termination date as determined by the Town. Such payment shall not exceed the fair value of the supplies provided hereunder.

ARTICLE 6: INDEMNIFICATION:

The Contractor shall defend, indemnify and hold harmless the Town and its officers, agents, and all employees from and against claims arising directly or indirectly from the contract. Contractor shall be solely responsible for all local taxes or contributions imposed or required under the Social Security, Workers' Compensation, and income tax laws. Further, the Contractor

shall defend, indemnify and hold harmless the Town with respect to any damages, expenses, or claims arising from or in connection with any of the work performed or to be performed under this Agreement. This shall not be construed as a limitation of the Contractor's liability under the Agreement or as otherwise provided by law.

ARTICLE 7: AVAILABILITY OF FUNDS:

The compensation provided by this Agreement is subject to the availability and appropriation of funds.

ARTICLE 8: APPLICABLE LAW:

The Contractor agrees to comply with all applicable local, state and federal laws, regulations and orders relating to the completion of this Agreement. This Agreement shall be governed by and construed in accordance with the law of the Commonwealth of Massachusetts.

ARTICLE 9: ASSIGNMENT:

The Contractor shall not make any assignment of this Agreement without the prior written approval of the Town.

ARTICLE 10: AMENDMENTS:

All amendments or any changes to the provisions specified in this Contract can only occur when mutually agreed upon by the Town and Contractor. Further, such amendments or changes shall be in writing and signed by officials with authority to bind the Town. No amendment or change to the contract provisions shall be made until after the written execution of the amendment or change to the Contract by both parties.

ARTICLE 11: INDEPENDENT CONTRACTOR:

The Contractor acknowledges and agrees that it is acting as an independent contractor for all work and supplies rendered pursuant to this Agreement and shall not be considered an employee or agent of the Town for any purpose.

ARTICLE 12: INSURANCE:

The Contractor shall be responsible to the Town or any third party for any property damage or bodily injury caused by it, any of its subcontractors, employees or agents in the performance of, or as a result of, the work under this Agreement. The Contractor and any subcontractors used hereby certify that they are insured for workers' compensation, property damage, personal and product liability. The Contractor and any subcontractor it uses shall purchase, furnish copies of, and maintain in full force and effect insurance policies in the amounts here indicated.

- 1) General Liability of at least \$1,000,000 Occurrence/\$3,000,000 General Aggregate. The Municipality should be named as an "Additional Insured". Products and Completed Operations should be maintained for up to 3 years after the completion of the project.
- 2) Automobile Liability (applicable for any contractor who has an automobile operating exposure) of at least \$1,000,000 Bodily Injury and Property Damage per accident. The Municipality should be named as an "Additional Insured".
- 3) Workers' Compensation Insurance as required by law. Include Employers Liability Part B with a limit of \$1,000,000
- 4) Property Coverage for materials and supplies being transported by the contractor, as the Town's Property Contract provides coverage for personal property within 1000 feet of the premises.

- 5) Umbrella Liability of at least \$2,000,000/ occurrence, \$2,000,000/aggregate. The Municipality should be named as an Additional Insured.

Prior to commencement of any work under this Agreement, the Contractor shall provide the Town with Certificates of Insurance which include the Town as an additional named insured and which include a thirty day notice of cancellation to the Town.

ARTICLE 13: SEVERABILITY:

If any term or condition of this Agreement or any application thereof shall to any extent be held invalid, illegal or unenforceable by the court of competent jurisdiction, the validity, legality, and enforceability of the remaining terms and conditions of this Agreement shall not be deemed affected thereby unless one or both parties would be substantially or materially prejudiced.

ARTICLE 14: ENTIRE AGREEMENT:

This Agreement, including all documents incorporated herein by reference, constitutes the entire integrated agreement between the parties with respect to the matters described. This Agreement supersedes all prior agreements, negotiations and representations, either written or oral, and it shall not be modified or amended except by a written document executed by the parties hereto.

ARTICLE 15: COUNTERPARTS:

This Agreement may be executed in any number of counterparts, each of which shall be deemed to be a counterpart original.

CERTIFICATION AS TO PAYMENT OF STATE TAXES

Pursuant to Chapter 62C of the Massachusetts General Laws, Section 49A(b), I, April Prater _____, authorized signatory for the Contractor do hereby certify under the pains and penalties of perjury that said Contractor has complied with all laws of the Commonwealth of Massachusetts relating to taxes, reporting of employees and contractors, and withholding and remitting child support.

81-1300894

Social Security Number or
Federal Identification Number

VERMEER MID ATLANTIC, LLC

Signature of Individual or
Corporate Name
DocuSigned by:
By: April Prater
Corporate Officer
(if applicable)

IN WITNESS WHEREOF, the parties hereto have caused this Agreement to be executed on the day and year first above written.

CONTRACTOR
By DocuSigned by:
April Prater

April Prater
Printed Name

TOWN OF HARWICH
by its Board of Selectmen Over \$50,000

CONTROLLER

Title

by its Town Administrator Up to \$50,000

Town Administrator

Approved as to Availability of Funds:
DocuSigned by:
Carol Coppola

Finance Director (\$60,039.00)
Contract Sum
State Recycling 12054392/558000,
Cemetery Revolving 1611002/558000,
Golf Capital Outlay 016958/585000

Project Name: FY'21 Cruiser Procurement TM Year and Article #: _____ Appropriation: \$ 108,257.40
Low Bidder: Colonial Municipal Group Police Operating Budget Bid Price: \$ _____

G-10: \$ 48,727.90
G-15: \$ 48,202.90

12/13/18 Revised Procurement Checklist

Please complete checklist below for contracts requiring Selectmen* signature **before Wednesday morning**** in order to get sign-off approval from the Town Administrator or the Assistant Town Administrator.

*Note: contracts (not grants) **below \$25,000** can be signed by Town Administrator.

- 1. Please provide a **separate page titled "Summary of Project"** which includes:
 - a. Provide how many bidders there were, the range of bids, and apparent low bidder. *M/A*
 - b. Identify the funding source, such as article number and amount approved.
 - c. Include what you feel is pertinent, but keep this section to 4 sentences or less. 012108/585000
DocuSigned by: Carol Coppola
- 2. Finance Director has signed that funds are available: _____ Account # _____
- 3. Please provide a single **copy of the bid packet** along with all supporting documents.
- 4. Please use K-P Law provided standardized contracts.

Buildings and Public Works	Goods and Services
<input type="checkbox"/> C1. Please show Prevailing Wage was used. <input type="checkbox"/> C2. If construction is near \$10,000 you also need: <input type="checkbox"/> a. Written spec sheet. <input type="checkbox"/> b. Advertised for two weeks on Central Register and COMMBUYS. <input type="checkbox"/> c. Apparent low bidder posted to Town website. <input type="checkbox"/> C3. If construction over \$25,000 you need C1, C2, as well as: <input type="checkbox"/> a. Show project was in the Capital Plan. <input type="checkbox"/> b. Low bidder provides 50% payment bond after Selectmen's countersignature. <input type="checkbox"/> C4. If construction over \$50,000 you need C1, C2, C3, as well as: <input type="checkbox"/> a. Bid Bond of 5% of total value. <input type="checkbox"/> b. Sealed Bids. <input type="checkbox"/> c. End of Public Works construction requirements <input type="checkbox"/> C5. If Building estimated construction costs are over \$300,000 and estimated design costs are over \$30,000 you'll need to follow the Designer Selection RFQ process: <input type="checkbox"/> a. Advertise in Central Register and local newspaper for two weeks. <input type="checkbox"/> b. Set a designer fee or price ceiling. <input type="checkbox"/> c. Use Standard Designer Application Form <input type="checkbox"/> C6. If Building construction over \$150,000 you'll need C1, C2, C3, C4, C5, as well as: <input type="checkbox"/> a. 100% payment bond was in bids. <input type="checkbox"/> b. 100% performance bond was in bids. <input type="checkbox"/> c. DCAMM certified bidders. <input type="checkbox"/> i. DCAMM certified sub-bids if over \$25,000. <input type="checkbox"/> C7. If Building construction over \$10,000,000 you'll need C1, C2, C3, C4, C5, C6, as well as: <input type="checkbox"/> a. Solicit qualifications prior to sealed bids.	<input type="checkbox"/> GS1. If procured using the State Bid List : <input type="checkbox"/> a. Over \$25,000 please show project was on the Capital Plan. <input type="checkbox"/> GS2. If project is over \$5,000 : <input type="checkbox"/> a. Please provide written spec sheet used and who it was sent to. <input type="checkbox"/> b. Maximum contract length is three years. <input type="checkbox"/> GS3. If project is over \$50,000 : <input type="checkbox"/> a. Show project was advertised for two weeks in a newspaper and on COMMBUYS. <input type="checkbox"/> b. Show project utilized sealed bids. <input type="checkbox"/> c. Apparent low bidder posted to Town website. <input type="checkbox"/> GS4. If project is over \$100,000 : <input type="checkbox"/> a. Show project was advertised for two weeks in COMMBUYS and Goods and Services Bulletin. <input type="checkbox"/> b. Show project utilized sealed bids. Note 1: If lowest bidder was found to be either not responsive or not responsible, the Town may begin negotiations with next lowest bidder. Note 2: Bids may be negotiated downwards but never higher than original quote. Note 3: Municipalities shall not provide a down payment, deposit, or provide funding before possession of purchased item. <div style="border: 1px solid black; padding: 5px; text-align: center; color: red;"> Cooperative Purchase through Metropolitan Area Planning Council (MAPC) and Greater Boston Police Council (GBPC) </div>

Original for Accounting Original for Procurement Original for Vendor Contract to Treasurer's
Signature of Town Administrator or Assistant Town Administrator: *Joseph F. Powers*



HARWICHPolice
DEPARTMENT
183 Sisson Road, Harwich, MA 02645
Tel 508-430-7541 Fax 508-432-2530



DAVID J. GUILLEMETTE
Chief of Police

KEVIN M. CONSIDINE
Deputy Chief

To: Procurement
From: Deputy Chief Kevin M. Considine 
Date: February 25, 2021
Subject: FY '21 Cruiser Purchases

Project: In the FY '21 budget, the Harwich Police Department is authorized to purchase one (1) police cruiser. On July 5, 2020, one of our marked cruisers (G-15) was involved in a motor vehicle crash. This vehicle was deemed totaled. The town received a check for the damages which was added into our cruiser line item. As a result of the one cruiser authorized to purchase in the budget, and a second cruiser to purchase as a result of the crash, a total of two cruisers are required.

Description: The Harwich Police Department is seeking the purchase of two (2) 2020 Ford Police Utility cruisers and related aftermarket emergency equipment and lighting.

Funding: Cruiser Line Item: Obj: 012108 Org: 585000

Contract: Metropolitan Area Planning Council - Public Services Vehicles
Metropolitan Area Planning Council – Aftermarket Equipment

Vendor: CMG, Colonial Municipal Group

Quotes: G-10: \$48,727.90
G-15: \$48,202.90

PROCUREMENT CHECKLIST & APPROVAL FORM

STAFF LEAD: Deputy Chief Kevin Considine DEPARTMENT: Police

FUNDING SOURCE: FY '21 cruiser line item Obj: 012108 Org: 585000

Appropriated amount: \$108,257.40 Estimated cost: _____ Actual cost: _____

G-10 \$48,727.90
G-15 \$48,202.90

PROCUREMENT METHOD:

State Contract Metropolitan Area Planning Council, for both cruiser and aftermarket equipment.

PURCHASE DESCRIPTION:

Purchase descriptions should contain the following components (see document on purchase descriptions):
Description of supplies or services required; quantities required; schedule for performance and delivery terms.

The Harwich Police Department is seeking the purchase of two (2) marked 2020 Ford Police Utility Patrol cruisers and related aftermarket emergency equipment and lighting.

Vehicle's will be available for pick up once the build is complete. Harwich Police will pick up the cruisers and inspect prior to taking delivery.

Contact: Kevin M. Considine
Deputy Chief of Police
Harwich Police Department
183 Sisson Road
Harwich, Ma 02645

PROCUREMENT MAY PROCEED ONLY IF SIGNATURES PROVIDED BELOW

Funds Available: Finance Director: Carol Coppola Account # 012108/585000
48C32039D33D434...

Approved to proceed: Town Administrator or Designee: Joseph F. Powers
0623C0C5799644E...



Estimate

Date: 11/11/2020

Customer ID: HarwichPD

To: Harwich Police Department
 Attn: Dep Chief Considine
 183 Sisson Road
 Harwich, MA 02645
 508-237-8721

Salesperson: Michael Chase
 508-280-6603

Price Per GBPC/BAPERN

G10

Qty	Item #	Description	Unit Price	Line Total
1.00	K8A	2020 Ford Police Utility AWD Black	\$ 33,000.00	\$ 33,000.00
1.00	43D	Dark Car Feature	\$ 24.25	\$ 24.25
1.00	51R	Driver Side Spot Lamp Unity LED	\$ 383.70	\$ 383.70
1.00	549	Power Heated Mirrors	\$ 58.20	\$ 58.20
1.00	76R	Reverse Sensing System	\$ 266.75	\$ 266.75
1.00	Inc	SYNC Voice Activated System	\$ -	\$ -
1.00	Inc	Front Headlamp Housing	\$ -	\$ -
1.00	87R	Rear View Mirror with Rear Camera	\$ -	\$ -
1.00	18D	Rear Liftgate Lock Disable	\$ -	\$ -
1.00	Paint	Roof and 4 Doors White Lower	\$ 995.00	\$ 995.00
1.00	Tint	Tint Front Windows 35%	\$ 200.00	\$ 200.00
1.00	FK	Fleet Key	\$ 225.00	\$ 225.00
1.00	36-2125	Westin Push Bar	\$ 450.00	\$ 450.00
1.00	36-6005W4	Westin Push Bar Channel 4 Lights	\$ 50.00	\$ 50.00
2.00	I2E	Whelen ION Duo Multi Color Blue White Front of Push Bar(4)	\$ 360.00	\$ 720.00
1.00	TLI2E	Whelen ION T-Series Multi Color Blue White Side of Push Bar	\$ 360.00	\$ 360.00
1.00	VTX609-B	Whelen Vertex Front Hide a Ways Blue	\$ 300.00	\$ 300.00
1.00	C-VS-1012	Havis Console with Dual Holder and Arm Rest	\$ 650.00	\$ 650.00
1.00	C-LP1-USB	Havis USB and AUX Port	\$ 60.00	\$ 60.00
1.00	BSFW50Z	Whelen DUO XLP Inner Edge Full Blue White	\$ 1,200.00	\$ 1,200.00
1.00	LINSV2B	Whelen V-Series Comco 180 Warning/Puddle Blue Clear	\$ 495.00	\$ 495.00
1.00	TLI2E	Whelen ION Duo Multi Color Blue White Lift Gate Open	\$ 360.00	\$ 360.00
1.00	VTX609-R	Whelen Vertex Rear Hide a Way Red	\$ 300.00	\$ 300.00
1.00	VTX609-C	Whelen Vertex Rear Hide a Way Clear	\$ 300.00	\$ 300.00
1.00	BS508	Whelen SOLO RST Inner Edge Rear BRBBBBRB	\$ 960.00	\$ 960.00
1.00	I2E	Whelen ION Duo Multi Color Blue White Side Cargo	\$ 360.00	\$ 360.00

1.00	CW0410	Code 3 400 Light on Lift Gate	\$	90.00	\$	90.00
1.00	P1000UINT20A	Pro-Gard Procell Skins and Bars Pass Side Only Plexi Rear	\$	2,450.00	\$	2,450.00
1.00	Transfer	Mag Light with Charger Pass Side Console Ignition	\$	25.00	\$	25.00
1.00	I3SMJC	Whelen TRIO Surface Mount Red White Blue Rear Plate	\$	360.00	\$	360.00
1.00	894090	Front and Rear Vent Shades	\$	95.00	\$	95.00
1.00	TM-5126-PIU-20	Hint Mount with Patrol PC New Feet For PIU	\$	500.00	\$	500.00
1.00	SA315P	Whelen Siren Speaker	\$	230.00	\$	230.00
1.00	CCTL7/C399	Whelen CENCOM Core with WeCan OBDII	\$	1,500.00	\$	1,500.00
2.00	CANEM16	Whelen Lighting Extension Module	\$	260.00	\$	520.00
1.00	LCPHOTO	Whelen Logic Level Photo Cell	\$	100.00	\$	100.00
1.00	Transfer	Dual Head RADAR	\$	90.00	\$	90.00
1.00	Transfer	Radio	\$	190.00	\$	190.00
1.00	G6300D	Rifle Rack AR Front Shot Gun Side	\$	590.00	\$	590.00
1.00	SI240TIHPIU	Pro-Gard Safe Stop 2019 Ford PIU	\$	270.00	\$	270.00
1.00					\$	-

Special Instructions:

Vehicle Subtotal	\$34,727.90
Upfit Subtotal	\$14,000.00
Grand Total	\$48,727.90

Thank you for your business



Estimate

Date: 11/11/2020

Customer ID: HarwichPD

To: Harwich Police Department
 Attn: Dep Chief Considine
 183 Sisson Road
 Harwich, MA 02645
 508-237-8721

Salesperson: Michael Chase
 508-280-6603

Price Per GBPC/BAPERN

G15

Qty	Item #	Description	Unit Price	Line Total
1.00	K8A	2020 Ford Police Utility AWD Black	\$ 33,000.00	\$ 33,000.00
1.00	43D	Dark Car Feature	\$ 24.25	\$ 24.25
1.00	51R	Driver Side Spot Lamp Unity LED	\$ 383.70	\$ 383.70
1.00	549	Power Heated Mirrors	\$ 58.20	\$ 58.20
1.00	76R	Reverse Sensing System	\$ 266.75	\$ 266.75
1.00	Inc	SYNC Voice Activated System	\$ -	\$ -
1.00	Inc	Front Headlamp Housing	\$ -	\$ -
1.00	87R	Rear View Mirror with Rear Camera	\$ -	\$ -
1.00	18D	Rear Liftgate Lock Disable	\$ -	\$ -
1.00	Paint	Roof and 4 Doors White Lower	\$ 995.00	\$ 995.00
1.00	Tint	Tint Front Windows 35%	\$ 200.00	\$ 200.00
1.00	FK	Fleet Key	\$ 225.00	\$ 225.00
1.00	36-2125	Westin Push Bar	\$ 450.00	\$ 450.00
1.00	36-6005W4	Westin Push Bar Channel 4 Lights	\$ 50.00	\$ 50.00
2.00	I2E	Whelen ION Duo Multi Color Blue White Front of Push Bar(4)	\$ 360.00	\$ 720.00
1.00	TLI2E	Whelen ION T-Series Multi Color Blue White Side of Push Bar	\$ 360.00	\$ 360.00
1.00	VTX609-B	Whelen Vertex Front Hide a Ways Blue	\$ 300.00	\$ 300.00
1.00	C-VS-1012	Havis Console with Dual Holder and Arm Rest	\$ 650.00	\$ 650.00
1.00	C-LP1-USB	Havis USB and AUX Port	\$ 60.00	\$ 60.00
1.00	BSFW50Z	Whelen DUO XLP Inner Edge Full Blue White	\$ 1,200.00	\$ 1,200.00
1.00	LINSV2B	Whelen V-Series Comco 180 Warning/Puddle Blue Clear	\$ 495.00	\$ 495.00
1.00	TLI2E	Whelen ION Duo Multi Color Blue White Lift Gate Open	\$ 360.00	\$ 360.00
1.00	VTX609-R	Whelen Vertex Rear Hide a Way Red	\$ 300.00	\$ 300.00
1.00	VTX609-C	Whelen Vertex Rear Hide a Way Clear	\$ 300.00	\$ 300.00
1.00	BS508	Whelen SOLO RST Inner Edge Rear BRBBBBRB	\$ 960.00	\$ 960.00
1.00	I2E	Whelen ION Duo Multi Color Blue White Side Cargo	\$ 360.00	\$ 360.00

1.00	CW0410	Code 3 400 Light on Lift Gate	\$	90.00	\$	90.00
1.00	P1000UINT20A	Pro-Gard Procell Skins and Bars Pass Side Only Plexi Rear	\$	2,450.00	\$	2,450.00
1.00	Transfer	Mag Light with Charger Pass Side Console Ignition	\$	25.00	\$	25.00
1.00	I3SMJC	Whelen TRIO Surface Mount Red White Blue Rear Plate	\$	360.00	\$	360.00
1.00	894090	Front and Rear Vent Shades	\$	95.00	\$	95.00
1.00	TM-5126-PIU-20	Hint Mount with Patrol PC New Feet For PIU	\$	500.00	\$	500.00
1.00	SA315P	Whelen Siren Speaker	\$	230.00	\$	230.00
1.00	CCTL7/C399	Whelen CENCOM Core with WeCan OBDII	\$	1,500.00	\$	1,500.00
2.00	CANEM16	Whelen Lighting Extension Module	\$	260.00	\$	520.00
1.00	LCPHOTO	Whelen Logic Level Photo Cell	\$	100.00	\$	100.00
1.00	Transfer	Dual Head RADAR	\$	90.00	\$	90.00
1.00	Transfer	Radio	\$	190.00	\$	190.00
1.00	Transfer	Rifle Rack AR Front Shot Gun Side	\$	65.00	\$	65.00
1.00	SI240TIHPIU	Pro-Gard Safe Stop 2019 Ford PIU	\$	270.00	\$	270.00
1.00					\$	-

Special Instructions:

Vehicle Subtotal	\$34,727.90
Upfit Subtotal	\$13,475.00
Grand Total	\$48,202.90

Thank you for your business



SMART GROWTH AND REGIONAL COLLABORATION

August 21, 2020

Frank C. Chase
President
Colonial Ford, Inc.
dba Colonial Municipal Group
11 Pilgrim Hill Road
Plymouth, MA 02360

Re: RFP # GBPC 2019 Public Service Vehicles
Contract Extension

Dear Clay:

Please accept this letter as notice that the Metropolitan Area Planning Council ("MAPC"), in accordance with Section 3.7 of the contract referenced above, hereby exercises its retained option to extend its contract with Colonial Ford, Inc. dba Colonial Municipal Group for an additional one-year term from September 30, 2020 through September 30, 2021.

As per the contract, your company is allowed to submit renewed pricing for the new contract year. Price escalations are contractually limited to 10% for any product under contract. Please send your revised pricing, in the same format as currently is used, to Kelsi Champley (kchampley@mapc.org) as soon as possible. Once approved, the new pricing will be added onto the MAPC website for municipal buyers to use.

On behalf of the Greater Boston Police Council ("GBPC") and MAPC, I thank you for your continued services.

Sincerely,

Mark Fine

MARK SAMUEL FINE
DIRECTOR, MUNICIPAL COLLABORATION
Metropolitan Area Planning Council
O#: (617) 933-0789 / C#: (617) 455-9416 / mfine@mapc.org

CONTRACT FOR GOODS AND SERVICES

BY AND BETWEEN

METROPOLITAN AREA PLANNING COUNCIL

AND

COLONIAL FORD INC DBA COLONIAL MUNICIPALGROUP

This AGREEMENT, dated 9/27/19, is made and entered into by and between the Metropolitan Area Planning Council ["MAPC"], a public body politic and corporate, established by Chapter 40B, Sections 24 through 29 of the Massachusetts General Laws, with its principal office at 60 Temple Place, Boston, Massachusetts 02111, acting as the collective purchasing agent for the Greater Boston Police Council, Inc. ["GBPC"] and its Members ["Buyers"] pursuant to Chapter 7, Section 22B of the Massachusetts General Laws and without liability to MAPC, COLONIAL FORD INC DBA COLONIAL MUNICIPAL GROUP ["Vendor"], with its principal office at Vendor's Address.

Witnesseth that the parties AGREE as follows:

Article I

General Description of the Work

1. Pursuant to the Terms and Conditions of this AGREEMENT, including any Additional and Special Terms and Conditions listed in Exhibit C, the Request for Proposals ["RFP"] - RFP No. GBPC 2019 Vehicles attached in Exhibit B; and the Vendor's Price Proposal and Technical Proposal attached in Exhibit E, MAPC hereby engages the Vendor to provide the following goods and/or services to the Buyers: Public Service Vehicles and Equipment.

Article II

Services of the Vendor

2. The Vendor will provide the goods and/or services as described in the RFP cited in Article 1 (above).
3. The Vendor shall report, and be responsible, to MAPC or its designee as set forth on Exhibit A.
4. There shall be no amendment to this AGREEMENT without the written approval of MAPC. MAPC shall be under no obligation to pay for any goods provided or services performed by the Vendor.
5. The Vendor represents and warrants to MAPC as follows:
 - i. That it and all its personnel (whether employees, agents or independent Vendors) are qualified and duly licensed as required by law and/or local municipal code to provide services and/or goods required by this AGREEMENT.

- ii. That it further agrees to perform services, including manufacturing, in a professional manner adhering to a reasonable standard of care and in accordance with all applicable State or Federal laws, rules and regulations.
- iii. That it will obtain any and all permits, bonds, insurances and other items required for the proper and legal performance of the work.
- iv. That it is not a party to any AGREEMENT, contract or understanding, which would in any way restrict or prohibit it from undertaking or performing its obligations hereunder in accordance with the terms and conditions of this AGREEMENT.

Article III

Performance of the Vendor

6. In the performance of service under this AGREEMENT, the Vendor acts at all times as an independent contractor. There is no relationship of employment or agency between MAPC, on the one hand, and the Vendor on the other, and neither party shall have nor exercise any control or direction over the method by which the other performs its work or functions aside from such control or directions as provided in this AGREEMENT which the parties view as consistent with their independent Vendor relationship.
7. The Vendor agrees to be responsible for and warrantee the work of its subcontractors listed in Exhibit D and to ensure their compliance with all legal, quality and performance requirements of the Request for Proposals ["RFP"] – RFP No. attached in Exhibit B; and the Vendor's Price Proposal and Technical Proposal attached in Exhibit F. The Vendor may not use subcontractors not named in Exhibit D without the prior written consent of MAPC, which will not unreasonably be withheld.

Article IV

Time of Performance

8. Time shall be of the essence in relation to Vendor's performance under this AGREEMENT. Vendor shall complete performance as promised in its quote that accompanies the Buyer's purchase order or other document confirming its authorization to the Vendor to proceed. Reasonable extensions shall be granted by the Buyer at the written request of the Vendor, provided the justifying circumstances are documented by and are beyond the reasonable control of Vendor and without fault of Vendor. In the event of such an extension, all other terms and conditions of this AGREEMENT, except the dates of commencement and completion of performance, shall remain in full force and effect between the parties unless modified in writing.
9. In the absence of such an extension, liquidated damages shall be due the Buyer in the amount of 0.1% (one-tenth of one percent) of the face value of the Vendor's quoted or modified purchase price for each day performance exceeds the promised date(s). Such liquidated damages may be acknowledged in Vendor's final invoice or taken by Buyer as a deduction to such final invoice.
10. Any dispute in the amount of liquidated damages shall be submitted to arbitration by either Buyer or Vendor through the American Arbitration Association within 10 (ten) business days of written notice given by the party declaring impasse. Vendor and Buyer agree to fully comply with the arbitrator's decision within a reasonable time.

Article V

Revisions in the Work to Be Performed

11. If during the Vendor's Time of Performance, Buyer requires revisions or other changes to be made in the scope or character of the work to be performed, Buyer will promptly notify Vendor in writing. For any changes to the scope of work, Vendor shall provide Buyer with a written quote of change in price and/or change in time of performance and shall proceed with such changes only upon written consent of Buyer, which shall be construed as a modification to Buyer's original purchase order.
12. Buyer will neither unreasonably request revisions nor unreasonably withhold final acceptance of delivered products.

Article VI

Term of Agreement

13. The term of this AGREEMENT shall commence upon execution and will continue until September 30, 2019, or until otherwise terminated as provided by this AGREEMENT or the RFP.
14. MAPC reserves the right at its sole discretion to extend the contract for up to two (2) additional one-year terms ending September 30, 2020 and September 30, 2021 respectively.
15. In the event new contracts have not been procured and awarded before the end of a second contract extension, MAPC reserves the right at its sole discretion to extend the contract for an additional period of time until new contracts have been procured and awarded. However, in no instance shall any contract term, including extensions, exceed three (3) years in total.
16. The Vendor agrees to perform promptly upon execution of this AGREEMENT and will diligently and faithfully perform in accordance with the provisions hereof.

Article VII

Orders, Fees, Invoices, and Payments

17. Orders, fees, invoices, and payment shall be processed and paid as specified in Section 10-Terms & Conditions of the RFP.
 - i. The parties agree that MAPC will only process invoicing for items or services specifically priced within the Vendor's Price Proposal as submitted to MAPC. MAPC will reject any price quotes or invoices that include any items or services that are not specifically priced in the Price Proposal. . In such instance, MAPC may require the Vendor to submit a corrected quote or invoice, or to clearly identify those items not included in the MAPC contract, to be labeled as "not on MAPC contract".

Article VIII

Assignment

18. Neither party shall assign, transfer or otherwise dispose of this AGREEMENT or any of its rights hereunder or otherwise delegate any of its duties hereunder without the prior written consent of the other party. Any such attempted assignment or other disposition without such consent shall be null and void and of no force and effect.

Article IX

Indemnification

19. The Vendor agrees to indemnify and save MAPC, GBPC, and the Buyers harmless from any and all manner of suits, claims, or demands arising out of any errors, omissions or negligence by the Vendor (including all its employees or agents) in performing under this AGREEMENT, or any breach of the terms of this AGREEMENT, which constitute an obligation of the Vendor. The Vendor shall reimburse MAPC, GBPC, and the Buyers for any and all costs, damages, and expenses including reasonable attorney's fees which MAPC, GBPC, and the Buyers pays, or becomes obligated to pay, by reason of such activities or breach. The provisions of this Section shall be in addition to and shall not be construed as a limitation on any other legal rights of MAPC, GBPC, and the Buyers expressed or not expressed in the RFP and with respect to this AGREEMENT.

Article X

Insurance

20. Before performing under this AGREEMENT, the Vendor shall obtain, and shall maintain throughout the term of this AGREEMENT, insurance at limits specified in the RFP and provide written documentation of such in the form specified in the RFP.
21. The Vendor shall give MAPC 20 days (twenty) written notice and copies of documentation in the event of any change or cancellation of coverage.

Article XI

Termination of Agreement

22. Either MAPC or the Vendor may terminate this AGREEMENT for cause upon written notice given by the non-defaulting party. For the purposes of this provision, "cause" shall include the failure of a party to fulfill its material duties hereunder in a timely and satisfactory manner.
23. MAPC shall have the right to terminate this AGREEMENT for its convenience upon fourteen (14) calendar days of written notice.
24. Following termination of this AGREEMENT, the parties shall be relieved of all further obligations hereunder except that:
25. MAPC shall not be liable for payments for the services and/or expenses or lost profits of the Vendor in the event of termination.

26. The Vendor shall remain liable for any damages, expenses or liabilities arising under this AGREEMENT (including its indemnity obligations) with respect to work performed pursuant to the AGREEMENT.

Article XII

Entirety of Agreement

27. This AGREEMENT, together with its Exhibits, the RFP referenced above and its Addenda, the required supplemental documents and any additional exhibits, constitute the entire AGREEMENT between MAPC and the Vendor with respect to the matters set forth therein and may not be changed (amended, modified or terms waived) except by a writing signed by both parties. Any notices required or allowed shall be sent by receipt-verified mail, email, fax or courier to the persons designated in Exhibit A.
28. The provisions of the RFP and the Vendor's Proposal are incorporated herein by reference. In the event of any conflict among the Contract Documents, the documents shall be construed according to the following priorities:

Highest Priority:	Amendments to Contract (if any)
Second Priority:	Contract
Third Priority:	Addenda to the RFP (if any)
Fourth Priority:	RFP
Fifth Priority:	Vendor's Proposal

Article XIII

Severability

29. In the event any provision of this AGREEMENT is found by a court of appropriate jurisdiction to be unlawful or invalid, the remainder of the AGREEMENT shall remain and continue in full force and effect.

Article XIV

Governing Law and Jurisdiction

30. This AGREEMENT shall be governed by, construed and enforced in accordance with laws of the Commonwealth of Massachusetts. MAPC, Vendors, and Buyers agree to submit their respective jurisdiction and venue to the state and federal courts in the Commonwealth of Massachusetts to resolve any disputes or disagreements that may arise under any provision of this AGREEMENT.

Article XV

Notice

31. Except as otherwise expressly provided in this AGREEMENT, any decision or action by MAPC relating to this AGREEMENT, its operation, or termination, shall be made only by MAPC or its designated representative identified in Exhibit A.

IN WITNESS WHEREOF, the parties have caused this AGREEMENT to be executed by their duly authorized officers on the date written below.

For MAPC by or on behalf of the Greater Boston Police Council and its Members:

x [Signature]
Signature

9/27/18
Date

Marc Draisen

Name

Executive Director

Title

For the VENDOR:

x [Signature]
* Signature

9/17/18
* Date

Frank C Chase

* Name

President

* Title

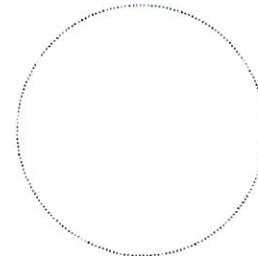

* Affix Corporate Seal (or mark "n/a")

EXHIBIT A

Notice Addressees

For MAPC:

Marc Draisen

Name

Executive Director

Title

MAPC

Organization

60 Temple Place

Street Address

Boston, MA 02111

City, State, ZIP

617.933.0700

Phone

617.482.7185

Fax

mdraisen@mapc.org

email

For the VENDOR:

Frank C. Chase

* Name

President

* Title

Colonial FARCI, Inc. CEO
Colonial Municipal Group

Organization

11 Pilgrim Hill Rd

* Street Address

Plymouth, MA 02360

* Street Address

771.283.6400

* Phone

771.283.6401

* Fax

c.chase@buyers.com

* email



GORDCHE-02

JLABO

CERTIFICATE OF LIABILITY INSURANCE

DATE (MM/DD/YYYY)
10/10/2018

THIS CERTIFICATE IS ISSUED AS A MATTER OF INFORMATION ONLY AND CONFERS NO RIGHTS UPON THE CERTIFICATE HOLDER. THIS CERTIFICATE DOES NOT AFFIRMATIVELY OR NEGATIVELY AMEND, EXTEND OR ALTER THE COVERAGE AFFORDED BY THE POLICIES BELOW. THIS CERTIFICATE OF INSURANCE DOES NOT CONSTITUTE A CONTRACT BETWEEN THE ISSUING INSURER(S), AUTHORIZED REPRESENTATIVE OR PRODUCER, AND THE CERTIFICATE HOLDER.

IMPORTANT: If the certificate holder is an **ADDITIONAL INSURED**, the policy(ies) must have **ADDITIONAL INSURED** provisions or be endorsed. If **SUBROGATION IS WAIVED**, subject to the terms and conditions of the policy, certain policies may require an endorsement. A statement on this certificate does not confer rights to the certificate holder in lieu of such endorsement(s).

PRODUCER License # 1780862 HUB International New England 600 Longwater Drive Norwell, MA 02061-9146	CONTACT NAME Patricia Condon	
	PHONE (A/C, No, Ext): (781) 792-3243	FAX (A/C, No):
	E-MAIL ADDRESS: patricia.condon@hubinternational.com	
	INSURER(S) AFFORDING COVERAGE	NAIC #
INSURED Gordon Chevrolet, Inc. 171 Great Road Acton, MA 01720	INSURER A : Union Insurance Company	25844
	INSURER B : Acadia Insurance Company	31325
	INSURER C : Independence Casualty Insurance Company	11984
	INSURER D :	
	INSURER E :	
	INSURER F :	

COVERAGES CERTIFICATE NUMBER: REVISION NUMBER:

THIS IS TO CERTIFY THAT THE POLICIES OF INSURANCE LISTED BELOW HAVE BEEN ISSUED TO THE INSURED NAMED ABOVE FOR THE POLICY PERIOD INDICATED. NOTWITHSTANDING ANY REQUIREMENT, TERM OR CONDITION OF ANY CONTRACT OR OTHER DOCUMENT WITH RESPECT TO WHICH THIS CERTIFICATE MAY BE ISSUED OR MAY PERTAIN, THE INSURANCE AFFORDED BY THE POLICIES DESCRIBED HEREIN IS SUBJECT TO ALL THE TERMS, EXCLUSIONS AND CONDITIONS OF SUCH POLICIES. LIMITS SHOWN MAY HAVE BEEN REDUCED BY PAID CLAIMS.

INSR LTR	TYPE OF INSURANCE	ADD'L SUBR INSD / WVD	POLICY NUMBER	POLICY EFF (MM/DD/YYYY)	POLICY EXP (MM/DD/YYYY)	LIMITS
A	<input checked="" type="checkbox"/> COMMERCIAL GENERAL LIABILITY <input type="checkbox"/> CLAIMS-MADE <input checked="" type="checkbox"/> OCCUR GEN'L AGGREGATE LIMIT APPLIES PER: <input type="checkbox"/> POLICY <input type="checkbox"/> PROJECT <input type="checkbox"/> LOC OTHER:	X	CPA512197214	12/10/2017	12/10/2018	EACH OCCURRENCE \$ 1,000,000 DAMAGE TO RENTED PREMISES (Ea occurrence) \$ 500,000 MED EXP (Any one person) \$ 10,000 PERSONAL & ADV INJURY \$ 1,000,000 GENERAL AGGREGATE \$ 2,000,000 PRODUCTS - COMP/OP AGG \$ 1,000,000
B	<input checked="" type="checkbox"/> AUTOMOBILE LIABILITY <input checked="" type="checkbox"/> ANY AUTO OWNED AUTOS ONLY <input type="checkbox"/> SCHEDULED AUTOS <input checked="" type="checkbox"/> HIRED AUTOS ONLY Garage <input type="checkbox"/> NON-OWNED AUTOS ONLY	X	MGA512764014	12/10/2017	12/10/2018	COMBINED SINGLE LIMIT (Ea accident) \$ 1,000,000 BODILY INJURY (Per person) \$ BODILY INJURY (Per accident) \$ PROPERTY DAMAGE (Per accident) \$
B	<input checked="" type="checkbox"/> UMBRELLA LIAB <input checked="" type="checkbox"/> OCCUR <input type="checkbox"/> EXCESS LIAB <input type="checkbox"/> CLAIMS-MADE DED <input checked="" type="checkbox"/> RETENTION \$ 10,000		CUA512197314	12/10/2017	12/10/2018	EACH OCCURRENCE \$ 5,000,000 AGGREGATE \$ 5,000,000
C	WORKERS COMPENSATION AND EMPLOYERS' LIABILITY ANY PROPRIETOR/PARTNER/EXECUTIVE OFFICER/MEMBER EXCLUDED? (Mandatory in NH) <input checked="" type="checkbox"/> N / N/A If yes, describe under DESCRIPTION OF OPERATIONS below		WCI00126901	12/10/2017	12/10/2018	<input checked="" type="checkbox"/> PER STATUTE <input type="checkbox"/> OTHER E.L. EACH ACCIDENT \$ 500,000 E.L. DISEASE - EA EMPLOYEE \$ 500,000 E.L. DISEASE - POLICY LIMIT \$ 500,000

DESCRIPTION OF OPERATIONS / LOCATIONS / VEHICLES (ACORD 101, Additional Remarks Schedule, may be attached if more space is required)
 Named Insured includes: Gordon Chevrolet, Inc., Colonial Automotive Group, City Side Subaru, Inc., Colonial of Watertown, Inc. dba Colonial Buick GMC, Colonial Dodge, Inc., Colonial Ford, Inc., Colonial Import South, Inc. dba Colonial Honda of Dartmouth, Colonial Imports West, Inc. dba North End Mazda, Colonial Imports, Inc. dba North End Subaru, Colonial Nissan of Medford, Inc., Colonial South Chevrolet, Inc., Colonial Volkswagen Inc. dba Colonial VW of Medford, Colonial West Chevrolet, Inc., Gordon Volkswagen, Inc. dba Colonial Volkswagen, Wellesley Volkswagen, Inc., Colonial South Automotive, Inc., Gordon Colonial, Inc. dba Colonial Cadillac, Colonial Ford of Marlborough, Inc., 100-104 Mystic Avenue, LLC, Empire Management Corp., Source One Financial Corp., Wamesit Place LLC, Lower Village LLC, Colonial Municipal Group

SEE ATTACHED ACORD 101

CERTIFICATE HOLDER Metropolitan Area Planning Council 60 Temple Place 6th Floor Boston, MA 02111	CANCELLATION SHOULD ANY OF THE ABOVE DESCRIBED POLICIES BE CANCELLED BEFORE THE EXPIRATION DATE THEREOF, NOTICE WILL BE DELIVERED IN ACCORDANCE WITH THE POLICY PROVISIONS. AUTHORIZED REPRESENTATIVE
---	--



ADDITIONAL REMARKS SCHEDULE

AGENCY HUB International New England		License # 1780862	NAMED INSURED Gordon Chevrolet, Inc. 171 Great Road Acton, MA 01720
POLICY NUMBER SEE PAGE 1			
CARRIER SEE PAGE 1	NAIC CODE SEE P 1	EFFECTIVE DATE: SEE PAGE 1	

ADDITIONAL REMARKS

**THIS ADDITIONAL REMARKS FORM IS A SCHEDULE TO ACORD FORM,
FORM NUMBER: ACORD 25 FORM TITLE: Certificate of Liability Insurance**

**Description of Operations/Locations/Vehicles:
Metropolitan Area Planning Council (MAPC) and Greater Boston Police Council (GBPC) are named as an additional insured subject to the terms and conditions of the General Liability and Automobile Liability when required by written contract.**



SMART GROWTH AND REGIONAL COLLABORATION

August 21, 2020

Frank C. Chase
President
Colonial Ford, Inc.
dba Colonial Municipal Group
61 Camelot Drive
Plymouth, MA 02360

Re: RFP # GBPC 2019 Aftermarket Equipment
Contract Extension

Dear Clay:

Please accept this letter as notice that the Metropolitan Area Planning Council ("MAPC"), in accordance with Section 3.7 of the contract referenced above, hereby exercises its retained option to extend its contract with Colonial Ford, Inc. dba Colonial Municipal Group for an additional one-year term from September 30, 2020 through September 30, 2021.

As per the contract, your company is allowed to submit renewed pricing for the new contract year. Price escalations are contractually limited to 10% for any product under contract. Please send your revised pricing, in the same format as currently is used, to Kelsi Champley (kchampley@mapc.org) as soon as possible. Once approved, the new pricing will be added onto the MAPC website for municipal buyers to use.

On behalf of the Greater Boston Police Council ("GBPC") and MAPC, I thank you for your continued services.

Sincerely,

Mark Fine

MARK SAMUEL FINE
DIRECTOR, MUNICIPAL COLLABORATION
Metropolitan Area Planning Council
O#: (617) 933-0789 / C#: (617) 455-9416 / mfine@mapc.org

CONTRACT FOR GOODS AND SERVICES

BY AND BETWEEN

METROPOLITAN AREA PLANNING COUNCIL

AND

COLONIAL FORD INC DBA COLONIAL MUNICIPAL GROUP

This AGREEMENT, dated 9-30-18, is made and entered into by and between the Metropolitan Area Planning Council ["MAPC"], a public body politic and corporate, established by Chapter 40B, Sections 24 through 29 of the Massachusetts General Laws, with its principal office at 60 Temple Place, Boston, Massachusetts 02111, acting as the collective purchasing agent for the Greater Boston Police Council, Inc. ["GBPC"] and its Members ["Buyers"] pursuant to Chapter 7, Section 22B of the Massachusetts General Laws and without liability to MAPC, AND COLONIAL FORD INC DBA COLONIAL MUNICIPAL GROUP ["Vendor"], with its principal office at Vendor's Address.

Witnesseth that the parties AGREE as follows:

Article I

General Description of the Work

1. Pursuant to the Terms and Conditions of this AGREEMENT, including any Additional and Special Terms and Conditions listed in Exhibit C, the Request for Proposals ["RFP"] - RFP No. GBPC 2019 Aftermarket Equipment - Supplied and Installed attached in Exhibit B; and the Vendor's Price Proposal and Technical Proposal attached in Exhibit E, MAPC hereby engages the Vendor to provide the following goods and/or services to the Buyers: Aftermarket Equipment.

Article II

Services of the Vendor

2. The Vendor will provide the goods and/or services as described in the RFP cited in Article 1 (above).
3. The Vendor shall report, and be responsible, to MAPC or its designee as set forth on Exhibit A.
4. There shall be no amendment to this AGREEMENT without the written approval of MAPC. MAPC shall be under no obligation to pay for any goods provided or services performed by the Vendor.
5. The Vendor represents and warrants to MAPC as follows:

- ii. That it further agrees to perform services, including manufacturing, in a professional manner adhering to a reasonable standard of care and in accordance with all applicable State or Federal laws, rules and regulations.
- iii. That it will obtain any and all permits, bonds, insurances and other items required for the proper and legal performance of the work.
- iv. That it is not a party to any AGREEMENT, contract or understanding, which would in any way restrict or prohibit it from undertaking or performing its obligations hereunder in accordance with the terms and conditions of this AGREEMENT.

Article III

Performance of the Vendor

6. In the performance of service under this AGREEMENT, the Vendor acts at all times as an independent contractor. There is no relationship of employment or agency between MAPC, on the one hand, and the Vendor on the other, and neither party shall have nor exercise any control or direction over the method by which the other performs its work or functions aside from such control or directions as provided in this AGREEMENT which the parties view as consistent with their independent Vendor relationship.
7. The Vendor agrees to be responsible for and warrantee the work of its subcontractors listed in Exhibit D and to ensure their compliance with all legal, quality and performance requirements of the Request for Proposals ["RFP"] – RFP No. attached in Exhibit B; and the Vendor's Price Proposal and Technical Proposal attached in Exhibit F. The Vendor may not use subcontractors not named in Exhibit D without the prior written consent of MAPC, which will not unreasonably be withheld.

Article IV

Time of Performance

8. Time shall be of the essence in relation to Vendor's performance under this AGREEMENT. Vendor shall complete performance as promised in its quote that accompanies the Buyer's purchase order or other document confirming its authorization to the Vendor to proceed. Reasonable extensions shall be granted by the Buyer at the written request of the Vendor, provided the justifying circumstances are documented by and are beyond the reasonable control of Vendor and without fault of Vendor. In the event of such an extension, all other terms and conditions of this AGREEMENT, except the dates of commencement and completion of performance, shall remain in full force and effect between the parties unless modified in writing.
9. In the absence of such an extension, liquidated damages shall be due the Buyer in the amount of 0.1% (one-tenth of one percent) of the face value of the Vendor's quoted or modified purchase price for each day performance exceeds the promised date(s). Such liquidated damages may be acknowledged in Vendor's final invoice or taken by Buyer as a deduction to such final invoice.
10. Any dispute in the amount of liquidated damages shall be submitted to arbitration by either Buyer or Vendor through the American Arbitration Association within 10 (ten) business days of written notice given by the party declaring impasse. Vendor and Buyer agree to fully comply with the arbitrator's decision within a reasonable time.

Article V

Revisions in the Work to Be Performed

11. If during the Vendor's Time of Performance, Buyer requires revisions or other changes to be made in the scope or character of the work to be performed, Buyer will promptly notify Vendor in writing. For any changes to the scope of work, Vendor shall provide Buyer with a written quote of change in price and/or change in time of performance and shall proceed with such changes only upon written consent of Buyer, which shall be construed as a modification to Buyer's original purchase order.
12. Buyer will neither unreasonably request revisions nor unreasonably withhold final acceptance of delivered products.

Article VI

Term of Agreement

13. The term of this AGREEMENT shall commence upon execution and will continue until September 30, 2019, or until otherwise terminated as provided by this AGREEMENT or the RFP.
14. MAPC reserves the right at its sole discretion to extend the contract for up to two (2) additional one-year terms ending September 30, 2020 and September 30, 2021 respectively.
15. In the event new contracts have not been procured and awarded before the end of a second contract extension, MAPC reserves the right at its sole discretion to extend the contract for an additional period of time until new contracts have been procured and awarded. However, in no instance shall any contract term, including extensions, exceed three (3) years in total.
16. The Vendor agrees to perform promptly upon execution of this AGREEMENT and will diligently and faithfully perform in accordance with the provisions hereof.

Article VII

Orders, Fees, Invoices, and Payments

17. Orders, fees, invoices, and payment shall be processed and paid as specified in Section 10-Terms & Conditions of the RFP.
 - i. The parties agree that MAPC will only process invoicing for items or services specifically priced within the Vendor's Price Proposal as submitted to MAPC. MAPC will reject any price quotes or invoices that include any items or services that are not specifically priced in the Price Proposal. . In such instance, MAPC may require the Vendor to submit a corrected quote or invoice, or to clearly identify those items not included in the MAPC contract, to be labeled as "not on MAPC contract".

Article VIII

Assignment

18. Neither party shall assign, transfer or otherwise dispose of this AGREEMENT or any of its rights hereunder or otherwise delegate any of its duties hereunder without the prior written consent of the other party. Any such attempted assignment or other disposition without such consent shall be null and void and of no force and effect.

Article IX

Indemnification

19. The Vendor agrees to indemnify and save MAPC, GBPC, and the Buyers harmless from any and all manner of suits, claims, or demands arising out of any errors, omissions or negligence by the Vendor (including all its employees or agents) in performing under this AGREEMENT, or any breach of the terms of this AGREEMENT, which constitute an obligation of the Vendor. The Vendor shall reimburse MAPC, GBPC, and the Buyers for any and all costs, damages, and expenses including reasonable attorney's fees which MAPC, GBPC, and the Buyers pays, or becomes obligated to pay, by reason of such activities or breach. The provisions of this Section shall be in addition to and shall not be construed as a limitation on any other legal rights of MAPC, GBPC, and the Buyers expressed or not expressed in the RFP and with respect to this AGREEMENT.

Article X

Insurance

20. Before performing under this AGREEMENT, the Vendor shall obtain, and shall maintain throughout the term of this AGREEMENT, insurance at limits specified in the RFP and provide written documentation of such in the form specified in the RFP.
21. The Vendor shall give MAPC 20 days (twenty) written notice and copies of documentation in the event of any change or cancellation of coverage.

Article XI

Termination of Agreement

22. Either MAPC or the Vendor may terminate this AGREEMENT for cause upon written notice given by the non-defaulting party. For the purposes of this provision, "cause" shall include the failure of a party to fulfill its material duties hereunder in a timely and satisfactory manner.
23. MAPC shall have the right to terminate this AGREEMENT for its convenience upon fourteen (14) calendar days of written notice.
24. Following termination of this AGREEMENT, the parties shall be relieved of all further obligations hereunder except that:
25. MAPC shall not be liable for payments for the services and/or expenses or lost profits of the Vendor in the event of termination.

26. The Vendor shall remain liable for any damages, expenses or liabilities arising under this AGREEMENT (including its indemnity obligations) with respect to work performed pursuant to the AGREEMENT.

Article XII

Entirety of Agreement

27. This AGREEMENT, together with its Exhibits, the RFP referenced above and its Addenda, the required supplemental documents and any additional exhibits, constitute the entire AGREEMENT between MAPC and the Vendor with respect to the matters set forth therein and may not be changed (amended, modified or terms waived) except by a writing signed by both parties. Any notices required or allowed shall be sent by receipt-verified mail, email, fax or courier to the persons designated in Exhibit A.
28. The provisions of the RFP and the Vendor's Proposal are incorporated herein by reference. In the event of any conflict among the Contract Documents, the documents shall be construed according to the following priorities:

Highest Priority:	Amendments to Contract (if any)
Second Priority:	Contract
Third Priority:	Addenda to the RFP (if any)
Fourth Priority:	RFP
Fifth Priority:	Vendor's Proposal

Article XIII

Severability

29. In the event any provision of this AGREEMENT is found by a court of appropriate jurisdiction to be unlawful or invalid, the remainder of the AGREEMENT shall remain and continue in full force and effect.

Article XIV

Governing Law and Jurisdiction

30. This AGREEMENT shall be governed by, construed and enforced in accordance with laws of the Commonwealth of Massachusetts. MAPC, Vendors, and Buyers agree to submit their respective jurisdiction and venue to the state and federal courts in the Commonwealth of Massachusetts to resolve any disputes or disagreements that may arise under any provision of this AGREEMENT.

Article XV

Notice

31. Except as otherwise expressly provided in this AGREEMENT, any decision or action by MAPC relating to this AGREEMENT, its operation, or termination, shall be made only by MAPC or its designated representative identified in Exhibit A.

IN WITNESS WHEREOF, the parties have caused this AGREEMENT to be executed by their duly authorized officers on the date written below.

For MAPC by or on behalf of the Greater Boston Police Council and its Members:

x [Signature]
Signature

10/15/18
Date

Marc Draisen
Name

Name

Executive Director
Title

Title

For the VENDOR:

x [Signature]
* Signature

9/26/18
* Date

Frank C. Chase
* Name

* Name

President
* Title

* Title

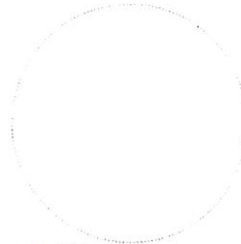

* Affix Corporate Seal (or mark "n/a")

EXHIBIT A

Notice Addressees

For MAPC:

Marc Draisen

Name

Executive Director

Title

MAPC

Organization

60 Temple Place

Street Address

Boston, MA 02111

City, State, ZIP

617.933.0700

Phone

617.482.7185

Fax

mdraisen@mapc.org

email

For the VENDOR:

Frank C. Chase

* Name

President

* Title

Colonial Ford, Inc. CEO
Colonial Municipal Group

Organization

61 Cornhill Dr.

* Street Address

Plymouth, MA 02360

* Street Address

774.283.6400

* Phone

774.283.6491

* Fax

c.chase@buycom.com

* email

AGREEMENT FOR TOWN OF HARWICH

The following provisions shall constitute an Agreement between the Town of Harwich, acting by and through its Board of Selectmen, hereinafter referred to as "Town," and Colonial Municipal Group, with an address of 61 Camelot Dr, Plymouth, MA 02360, hereinafter referred to as "Contractor", effective as of the ____ day of March, 2021. In consideration of the mutual covenants contained herein, the parties agree as follows:

ARTICLE 1: SCOPE OF WORK:

The Contractor shall perform all work and furnish all supplies necessary to provide the Town with two (2) 2020 Ford Police Utility All Wheel Drive Police Cruisers with related aftermarket emergency equipment and lighting, including the scope of supplies set forth in Attachment A.

ARTICLE 2: TIME OF PERFORMANCE:

The Contractor shall complete all work, supplies, and deliver by June 15, 2021.

ARTICLE 3: COMPENSATION:

The Town shall pay the Contractor for the performance of the work outlined in Article 1 above the contract sum of \$96,930.80. The Contractor shall submit monthly invoices to the Town for supplies rendered, which will be due 30 days following receipt by the Town.

ARTICLE 4: CONTRACT DOCUMENTS:

The following documents form the Contract and all are as fully a part of the Contract as if attached to this Agreement or repeated herein:

1. This Agreement.
2. Amendments, or other changes mutually agreed upon between the parties.
3. All attachments to the Agreement.

4. The Metropolitan Area Planning Council (MAPC) Greater Boston Police Council Contract (GBPC) 2019 Public Service Vehicles Contract with Colonial Ford Inc DBA Colonial Municipal Group, dated September 27, 2018.

In the event of conflicting provisions, those provisions most favorable to the Town shall govern.

ARTICLE 5: CONTRACT TERMINATION:

The Town may suspend or terminate this Agreement by providing the Contractor with ten (10) days written notice for the reasons outlined as follows:

1. Failure of the Contractor, for any reason, to fulfill in a timely and proper manner its obligations under this Agreement.
2. Violation of any of the provisions of this Agreement by the Contractor.
3. A determination by the Town that the Contractor has engaged in fraud, waste, mismanagement, misuse of funds, or criminal activity with any funds provided by this Agreement.

Either party may terminate this Agreement at any time for convenience by providing the other party written notice specifying therein the termination date which shall be no sooner than thirty (30) days from the issuance of said notice. Upon receipt of a notice of termination from the Town, the Contractor shall cease to incur additional expenses in connection with the Agreement. Upon such termination, the Contractor shall be entitled to compensation for all satisfactory work completed prior to the termination date as determined by the Town. Such payment shall not exceed the fair value of the supplies provided hereunder.

ARTICLE 6: INDEMNIFICATION:

The Contractor shall defend, indemnify and hold harmless the Town and its officers, agents, and all employees from and against claims arising directly or indirectly from the contract. Contractor shall be solely responsible for all local taxes or contributions imposed or required under the Social Security, Workers' Compensation, and income tax laws. Further, the Contractor

shall defend, indemnify and hold harmless the Town with respect to any damages, expenses, or claims arising from or in connection with any of the work performed or to be performed under this Agreement. This shall not be construed as a limitation of the Contractor's liability under the Agreement or as otherwise provided by law.

ARTICLE 7: AVAILABILITY OF FUNDS:

The compensation provided by this Agreement is subject to the availability and appropriation of funds.

ARTICLE 8: APPLICABLE LAW:

The Contractor agrees to comply with all applicable local, state and federal laws, regulations and orders relating to the completion of this Agreement. This Agreement shall be governed by and construed in accordance with the law of the Commonwealth of Massachusetts.

ARTICLE 9: ASSIGNMENT:

The Contractor shall not make any assignment of this Agreement without the prior written approval of the Town.

ARTICLE 10: AMENDMENTS:

All amendments or any changes to the provisions specified in this Contract can only occur when mutually agreed upon by the Town and Contractor. Further, such amendments or changes shall be in writing and signed by officials with authority to bind the Town. No amendment or change to the contract provisions shall be made until after the written execution of the amendment or change to the Contract by both parties.

ARTICLE 11: INDEPENDENT CONTRACTOR:

The Contractor acknowledges and agrees that it is acting as an independent contractor for all work and supplies rendered pursuant to this Agreement and shall not be considered an employee or agent of the Town for any purpose.

ARTICLE 12: INSURANCE:

The Contractor shall be responsible to the Town or any third party for any property damage or bodily injury caused by it, any of its subcontractors, employees or agents in the performance of, or as a result of, the work under this Agreement. The Contractor and any subcontractors used hereby certify that they are insured for workers' compensation, property damage, personal and product liability. The Contractor and any subcontractor it uses shall purchase, furnish copies of, and maintain in full force and effect insurance policies in the amounts here indicated.

- 1) General Liability of at least \$1,000,000 Occurrence/\$2,000,000 General Aggregate. The Municipality should be named as an "Additional Insured". Products and Completed Operations should be maintained for up to 3 years after the completion of the project.
- 2) Automobile Liability (applicable for any contractor who has an automobile operating exposure) of at least \$1,000,000 Bodily Injury and Property Damage per accident. The Municipality should be named as an "Additional Insured".
- 3) Workers' Compensation Insurance as required by law. Include Employers Liability Part B with a limit of \$500,000
- 4) Property Coverage for materials and supplies being transported by the contractor, as the Town's Property Contract provides coverage for personal property within 1000 feet of the premises.

- 5) Umbrella Liability of at least \$5,000,000/occurrence, \$5,000,000/aggregate. The Municipality should be named as an Additional Insured.

Prior to commencement of any work under this Agreement, the Contractor shall provide the Town with Certificates of Insurance which include the Town as an additional named insured and which include a thirty day notice of cancellation to the Town.

ARTICLE 13: SEVERABILITY:

If any term or condition of this Agreement or any application thereof shall to any extent be held invalid, illegal or unenforceable by the court of competent jurisdiction, the validity, legality, and enforceability of the remaining terms and conditions of this Agreement shall not be deemed affected thereby unless one or both parties would be substantially or materially prejudiced.

ARTICLE 14: ENTIRE AGREEMENT:

This Agreement, including all documents incorporated herein by reference, constitutes the entire integrated agreement between the parties with respect to the matters described. This Agreement supersedes all prior agreements, negotiations and representations, either written or oral, and it shall not be modified or amended except by a written document executed by the parties hereto.

ARTICLE 15: COUNTERPARTS:

This Agreement may be executed in any number of counterparts, each of which shall be deemed to be a counterpart original.

CERTIFICATION AS TO PAYMENT OF STATE TAXES

Pursuant to Chapter 62C of the Massachusetts General Laws, Section 49A(b), I, Frank C Chase _____, authorized signatory for the Contractor do hereby certify under the pains and penalties of perjury that said Contractor has complied with all laws of the Commonwealth of Massachusetts relating to taxes, reporting of employees and contractors, and withholding and remitting child support.

04-3575965

Social Security Number or
Federal Identification Number

Colonial Ford Inc., dba Colonial Municipal

Signature of Individual or
Corporate Name

DocuSigned by:
By: *Frank C Chase*
FACDE71326C941D...
Corporate Officer
(if applicable)

IN WITNESS WHEREOF, the parties hereto have caused this Agreement to be executed on the day and year first above written.

CONTRACTOR

TOWN OF HARWICH

By DocuSigned by:
Frank C Chase
FACDE71326C941D...

by its Board of Selectmen Over \$50,000

Frank C Chase

Printed Name

President

Title

Approved as to Availability of Funds:

by its Town Administrator Up to \$50,000

DocuSigned by:
Carol Coppola
40C92039D99D434...
Finance Director (\$96,930.80)
Contract Sum
012108/585000

Town Administrator

ATTACHMENT A



Estimate

Date: 11/11/2020

Customer ID: HarwichPD

To: Harwich Police Department
 Attn: Dep Chief Considine
 183 Sisson Road
 Harwich, MA 02645
 508-237-8721

Salesperson: Michael Chase
 508-280-6603

Price Per GBPC/BAPERN

G10

Qty	Item #	Description	Unit Price	Line Total
1.00	K8A	2020 Ford Police Utility AWD Black	\$ 33,000.00	\$ 33,000.00
1.00	43D	Dark Car Feature	\$ 24.25	\$ 24.25
1.00	51R	Driver Side Spot Lamp Unity LED	\$ 383.70	\$ 383.70
1.00	549	Power Heated Mirrors	\$ 58.20	\$ 58.20
1.00	76R	Reverse Sensing System	\$ 266.75	\$ 266.75
1.00	Inc	SYNC Voice Activated System	\$ -	\$ -
1.00	Inc	Front Headlamp Housing	\$ -	\$ -
1.00	87R	Rear View Mirror with Rear Camera	\$ -	\$ -
1.00	18D	Rear Liftgate Lock Disable	\$ -	\$ -
1.00	Paint	Roof and 4 Doors White Lower	\$ 995.00	\$ 995.00
1.00	Tint	Tint Front Windows 35%	\$ 200.00	\$ 200.00
1.00	FK	Fleet Key	\$ 225.00	\$ 225.00
1.00	36-2125	Westin Push Bar	\$ 450.00	\$ 450.00
1.00	36-6005W4	Westin Push Bar Channel 4 Lights	\$ 50.00	\$ 50.00
2.00	I2E	Whelen ION Duo Multi Color Blue White Front of Push Bar(4)	\$ 360.00	\$ 720.00
1.00	TLI2E	Whelen ION T-Series Multi Color Blue White Side of Push Bar	\$ 360.00	\$ 360.00
1.00	VTX609-B	Whelen Vertex Front Hide a Ways Blue	\$ 300.00	\$ 300.00
1.00	C-VS-1012	Havis Console with Dual Holder and Arm Rest	\$ 650.00	\$ 650.00
1.00	C-LP1-USB	Havis USB and AUX Port	\$ 60.00	\$ 60.00
1.00	BSFW50Z	Whelen DUO XLP Inner Edge Full Blue White	\$ 1,200.00	\$ 1,200.00
1.00	LINSV2B	Whelen V-Series Comco 180 Warning/Puddle Blue Clear	\$ 495.00	\$ 495.00
1.00	TLI2E	Whelen ION Duo Multi Color Blue White Lift Gate Open	\$ 360.00	\$ 360.00
1.00	VTX609-R	Whelen Vertex Rear Hide a Way Red	\$ 300.00	\$ 300.00
1.00	VTX609-C	Whelen Vertex Rear Hide a Way Clear	\$ 300.00	\$ 300.00
1.00	BS508	Whelen SOLO RST Inner Edge Rear BRBBBBRB	\$ 960.00	\$ 960.00
1.00	I2E	Whelen ION Duo Multi Color Blue White Side Cargo	\$ 360.00	\$ 360.00

1.00	CW0410	Code 3 400 Light on Lift Gate	\$	90.00	\$	90.00
1.00	P1000UINT20A	Pro-Gard Procell Skins and Bars Pass Side Only Plexi Rear	\$	2,450.00	\$	2,450.00
1.00	Transfer	Mag Light with Charger Pass Side Console Ignition	\$	25.00	\$	25.00
1.00	I3SMJC	Whelen TRIO Surface Mount Red White Blue Rear Plate	\$	360.00	\$	360.00
1.00	894090	Front and Rear Vent Shades	\$	95.00	\$	95.00
1.00	TM-5126-PIU-20	Hint Mount with Patrol PC New Feet For PIU	\$	500.00	\$	500.00
1.00	SA315P	Whelen Siren Speaker	\$	230.00	\$	230.00
1.00	CCTL7/C399	Whelen CENCOM Core with WeCan OBDII	\$	1,500.00	\$	1,500.00
2.00	CANEM16	Whelen Lighting Extension Module	\$	260.00	\$	520.00
1.00	LCPHOTO	Whelen Logic Level Photo Cell	\$	100.00	\$	100.00
1.00	Transfer	Dual Head RADAR	\$	90.00	\$	90.00
1.00	Transfer	Radio	\$	190.00	\$	190.00
1.00	G6300D	Rifle Rack AR Front Shot Gun Side	\$	590.00	\$	590.00
1.00	SI240TIHPIU	Pro-Gard Safe Stop 2019 Ford PIU	\$	270.00	\$	270.00
1.00					\$	-

Special Instructions:

Vehicle Subtotal	\$34,727.90
Upfit Subtotal	\$14,000.00
Grand Total	\$48,727.90

Thank you for your business

ATTACHMENT A



Estimate

Date: 11/11/2020

Customer ID: HarwichPD

To: Harwich Police Department
 Attn: Dep Chief Considine
 183 Sisson Road
 Harwich, MA 02645
 508-237-8721

Salesperson: Michael Chase
 508-280-6603

Price Per GBPC/BAPERN

G15

Qty	Item #	Description	Unit Price	Line Total
1.00	K8A	2020 Ford Police Utility AWD Black	\$ 33,000.00	\$ 33,000.00
1.00	43D	Dark Car Feature	\$ 24.25	\$ 24.25
1.00	51R	Driver Side Spot Lamp Unity LED	\$ 383.70	\$ 383.70
1.00	549	Power Heated Mirrors	\$ 58.20	\$ 58.20
1.00	76R	Reverse Sensing System	\$ 266.75	\$ 266.75
1.00	Inc	SYNC Voice Activated System	\$ -	\$ -
1.00	Inc	Front Headlamp Housing	\$ -	\$ -
1.00	87R	Rear View Mirror with Rear Camera	\$ -	\$ -
1.00	18D	Rear Liftgate Lock Disable	\$ -	\$ -
1.00	Paint	Roof and 4 Doors White Lower	\$ 995.00	\$ 995.00
1.00	Tint	Tint Front Windows 35%	\$ 200.00	\$ 200.00
1.00	FK	Fleet Key	\$ 225.00	\$ 225.00
1.00	36-2125	Westin Push Bar	\$ 450.00	\$ 450.00
1.00	36-6005W4	Westin Push Bar Channel 4 Lights	\$ 50.00	\$ 50.00
2.00	I2E	Whelen ION Duo Multi Color Blue White Front of Push Bar(4)	\$ 360.00	\$ 720.00
1.00	TLI2E	Whelen ION T-Series Multi Color Blue White Side of Push Bar	\$ 360.00	\$ 360.00
1.00	VTX609-B	Whelen Vertex Front Hide a Ways Blue	\$ 300.00	\$ 300.00
1.00	C-VS-1012	Havis Console with Dual Holder and Arm Rest	\$ 650.00	\$ 650.00
1.00	C-LP1-USB	Havis USB and AUX Port	\$ 60.00	\$ 60.00
1.00	BSFW50Z	Whelen DUO XLP Inner Edge Full Blue White	\$ 1,200.00	\$ 1,200.00
1.00	LINSV2B	Whelen V-Series Comco 180 Warning/Puddle Blue Clear	\$ 495.00	\$ 495.00
1.00	TLI2E	Whelen ION Duo Multi Color Blue White Lift Gate Open	\$ 360.00	\$ 360.00
1.00	VTX609-R	Whelen Vertex Rear Hide a Way Red	\$ 300.00	\$ 300.00
1.00	VTX609-C	Whelen Vertex Rear Hide a Way Clear	\$ 300.00	\$ 300.00
1.00	BS508	Whelen SOLO RST Inner Edge Rear BRBBBBRB	\$ 960.00	\$ 960.00
1.00	I2E	Whelen ION Duo Multi Color Blue White Side Cargo	\$ 360.00	\$ 360.00

1.00	CW0410	Code 3 400 Light on Lift Gate	\$	90.00	\$	90.00
1.00	P1000UINT20A	Pro-Gard Procell Skins and Bars Pass Side Only Plexi Rear	\$	2,450.00	\$	2,450.00
1.00	Transfer	Mag Light with Charger Pass Side Console Ignition	\$	25.00	\$	25.00
1.00	I3SMJC	Whelen TRIO Surface Mount Red White Blue Rear Plate	\$	360.00	\$	360.00
1.00	894090	Front and Rear Vent Shades	\$	95.00	\$	95.00
1.00	TM-5126-PIU-20	Hint Mount with Patrol PC New Feet For PIU	\$	500.00	\$	500.00
1.00	SA315P	Whelen Siren Speaker	\$	230.00	\$	230.00
1.00	CCTL7/C399	Whelen CENCOM Core with WeCan OBDII	\$	1,500.00	\$	1,500.00
2.00	CANEM16	Whelen Lighting Extension Module	\$	260.00	\$	520.00
1.00	LCPHOTO	Whelen Logic Level Photo Cell	\$	100.00	\$	100.00
1.00	Transfer	Dual Head RADAR	\$	90.00	\$	90.00
1.00	Transfer	Radio	\$	190.00	\$	190.00
1.00	Transfer	Rifle Rack AR Front Shot Gun Side	\$	65.00	\$	65.00
1.00	SI240TIHPIU	Pro-Gard Safe Stop 2019 Ford PIU	\$	270.00	\$	270.00
1.00					\$	-

Special Instructions:

Vehicle Subtotal	\$34,727.90
Upfit Subtotal	\$13,475.00
Grand Total	\$48,202.90

Thank you for your business

OFFICE OF THE TOWN ADMINISTRATOR

Joseph F. Powers, *Town Administrator*
Meggan M. Eldredge, *Assistant Town Administrator*

Phone (508) 430-7513

Fax (508) 432-5039

732 MAIN STREET, HARWICH, MA 02645



Memo

To: Board of Selectmen
Joseph F. Powers, Town Administrator

From: Meggan Eldredge, Assistant Town Administrator
Griffin Ryder, Town Engineer

RE: Contract with Colonial Municipal Group for two (2) police cruisers

Date: March 24, 2021

This memorandum corresponds to *Contracts Agenda Item B. Discussion and possible vote for the Board of Selectmen to execute contract with Colonial Municipal Group for the purchase of two (2) police cruisers for the Police Department for \$98,930.80*

As you will see from the attached materials, this item was procured through the State Contract Metropolitan Area Planning Council, MGL, C. 30B. Funding for this purchase is included and covered in the FY21 Police Operating Budget.

I recommend the Board's approval and execution of this contract.

TOWN
ADMINISTRATOR'S
REPORT

TOWN OF HARWICH, MASSACHUSETTS
SEWERAGE WORKS IMPROVEMENTS PHASE 2 – CONTRACT #1
ROBERT B. OUR COMPANY
SEWER PROJECT

CONSTRUCTION SCHEDULE – WEEKLY UPDATE
Date Submitted: March 15, 2021

One Week Look Ahead (03/15/21-03/19/21)

- Pump Station Crew # 1
 - Continue Working on Spence's Trace & RT 137 Pump Station Site's
 - Continue Working on the Parshall Flume

Two Week Look Ahead (03/22/21-03/26/21)

- Pump Station Crew # 1
 - Continue Working on Spence's Trace & RT 137 Pump Station Site's
 - Continue Working on the Parshall Flume

Three Week Look Ahead (03/29/21-04/02/21)

- Pump Station Crew # 1
 - Continue Working on Spence's Trace & RT 137 Pump Station Site's
 - Continue Working on the Parshall Flume

Please note that this is a projected schedule and will be adjusted accordingly based on the Contractor's actual progress and the weather. On an as needed basis auxiliary crews will be performing testing, installing inverts, raising castings, paving , and performing general cleanup at various locations throughout the project area.

TOWN OF HARWICH, MASSACHUSETTS
SEWERAGE WORKS IMPROVEMENTS PHASE 2 – CONTRACT #2

CONSTRUCTION SCHEDULE – WEEKLY UPDATE

One Week Look Ahead (03/15-03/19)

- Pump Station Crew #1
 - Continue work at Church Street north and south pumping stations

Two Week Look Ahead (03/22-03/26)

- Pump Station Crew #1
 - Continue work at Church Street north and south pumping stations
- Sewer Crew #1
 - Flush and Clean Pipe Network

Three Week Look Ahead (03/29-04/02)

- Pump Station Crew #1
 - Continue work at Church Street north and south pumping stations

Please note that this is a projected schedule and will be adjusted accordingly based on the Contractor's actual progress and the weather. On an as needed basis auxiliary crews will be performing testing, installing inverts, raising castings, paving , and performing general cleanup at various locations throughout the project area.